

RADIO BROADCAST

WILLIS KINGSLEY WING, Editor

KEITH HENNEY
Director of the Laboratory

EDGAR H. FELIX
Contributing Editor

Vol. XI, No. 3

JULY, 1927

CONTENTS

Cover Design	From a Design by Harvey Hopkins Dunn	
Frontispiece	In the Radio Cabin of an England-Egypt-India Airplane	134
The Aurora and Fading	Austin G. Cooley	135
The March of Radio	An Editorial Interpretation	138
What the Radio Commission Is Accomplishing	Radio Control Unsettled in Australia	
Radio Freedom of Speech Impossible	Where Are the Listeners' Organizations?	
What Stations Shall Be Eliminated?	Misuse of the Word "Broadcasting"	
Unnecessary Duplication of Radio Standards	Probable Progress of Television	
Why Important Events Can't Always Be Broadcast	Two Announcements by the Westinghouse Company	
Radio Reception Is No Longer Seasonal	The Patent Situation	
	The Month in Radio	
A Low-Cost Battery Charger	James Millen	143
"Strays" from the Laboratory		146
Measuring Audio Amplifiers	Articulation Curves	
A Fine British Magazine	New Equipment	
Batteryless Receivers		
How to Build a 36-inch Cone	Warren T. Mithoff	148
Something About Single Control	Edgar H. Felix	151
A Lamp Socket A, B, C Device	Gilbert Edgar	153
An A, B, C Power-Supply Unit for 201-A Type Tubes	Roland F. Beers	155
Receiver Design for A. C. Operation	Howard E. Rhodes	157
The Listeners' Point of View	John Wallace	159
Sunday Broadcasting Is Five Years Behind the Times	British Listeners Want Lighter Broadcast Fare	
How It Feels to Face a Microphone For the First Time	Thumb Nail Reviews	
	Microphone Miscellany	
	Communications	
A Combined Push-Pull Power Amplifier and Socket B Device	The Laboratory Staff	163
A Portable Long-Wave Receiver	Keith Henney	165
As the Broadcaster Sees It	Carl Dreher	167
The Place of Television in the Progress of Science	Thirteen Years Ago	
What the Broadcast Technician Should Read	Radio Revolutionized Again	
Technical Problem for Broadcasters. No. 2	Solution to Technical Problem No. 2	
Technical Problem for Broadcasters. No. 3	Solution to Technical Problem No. 3	
Description of a Short-Wave Station	C. R. Runyon, Jr.	171
"Radio Broadcast's" Laboratory Information Sheets		176
No. 105 Measuring R. F. Resistance of a Coil	No. 109 The Threshold of Hearing and Feeling in the Ear	
No. 106 The UX-240 Type Tube	No. 110 Dry-Cell Tubes	
No. 107 Neutralization	No. 111 Index	
No. 108 High-Voltage Supply for 210 Type Tube	No. 112 Index	
Equipment for the Home Constructor		182
Manufacturers' Booklets Available		186
What Kit Shall I Buy?		190

AMONG OTHER THINGS. . .

THIS issue of RADIO BROADCAST is almost an A.C. current supply number, for there is a wealth of information on the new methods for running vacuum tube filaments and supplying B and C potentials too. Although the four articles concerned do not total a great number of pages, they are the result of a great deal of laboratory work, and they contain plenty of information to aid the home constructor. Both the Raytheon and the Q. R. S. high-current rectifier units have been carefully tested for many weeks in the RADIO BROADCAST Laboratory under Howard Rhodes's direction and applied to receivers of various sorts. Much interest will also attach to James Millen's descriptions of the remarkable A battery charger tube developed in the Raytheon laboratory.

THOSE of a theoretical turn of mind will find Austin Cooley's story dealing with the aurora and radio fading, as observed on the last MacMillan Arctic expedition, of considerable interest. Mr. Cooley's deductions are ingenious and perhaps will cast considerable light on some of the problems of radio transmission. Neither RADIO BROADCAST, nor indeed, Mr. Cooley, regard the theory as more than an entering wedge. We hope other investigators may be encouraged to make actual long-time measurements which will give us a better basis for conclusion.

RADIO men, traditionally, are argumentative souls and those who have turned their attention to the economics of the current supply of radio receivers will find some interesting figures on page 146 of this number. Our position is neutral, but discussion is interesting.

OUR correspondents are constantly asking us for lists of radio reading matter, text book and periodical. A very helpful list of recent works is found on page 168 of this issue. There are, of course, many other standard books of value, many of which have in the past been reviewed in this magazine.

RADIO BROADCAST for September will contain the first of an usually complete series of articles on the elimination of interference. These articles are practical and definite and should help many a puzzled citizen to improve local reception. A shielded neutrodyne which can be built from standard parts will be described in the same issue. It was designed by H. G. Reich, a member of the physics department at Cornell University. A beautiful 80-meter code and phone transmitter will be described, also, and it will delight the heart of all of us who are interested in a compact efficient transmitter for this wave-band.

MANY features of RADIO BROADCAST, as our readers have discovered and generously appreciated, are designed to supply regularly concise information which is not to be found elsewhere. The Laboratory Data Sheets were the first of these features of this nature, then "The Best in Current Radio Periodicals," the "Manufacturers' Booklets Available," and, with the June issue, we began a listing of kits for building receivers, together with a brief technical summary of each. Information about kits can be secured through the Service Department of RADIO BROADCAST by exactly the same procedure that so many of our readers have followed with the manufacturers' booklets.

—WILLIS KINGSLEY WING.

Doubleday, Page & Co.
MAGAZINES
COUNTRY LIFE
WORLD'S WORK
GARDEN & HOME BUILDER
RADIO BROADCAST
SHORT STORIES
EDUCATIONAL REVIEW
LE PETIT JOURNAL
EL ECO
FRONTIER STORIES
WEST

Doubleday, Page & Co.
BOOK SHOPS
(Books of all Publishers)
NEW YORK: LORD & TAYLOR BOOK SHOP
PENNSYLVANIA TERMINAL (2 Shops)
GRAND CENTRAL TERMINAL
38 WALL ST. and 520 LEXINGTON AVE.
848 MAOISON AVE. and 166 WEST 32ND ST.
ST. LOUIS: 223 N. 8TH ST. and 4914 MARYLAND AVE.
KANSAS CITY: 920 GRAND AVE. and 206 W. 47TH ST.
CLEVELAND: HIGBEE CO.
SPRINGFIELD, MASS.: MEEKINS, PACKARD & WHEAT

Doubleday, Page & Co.
OFFICES
GARDEN CITY, N. Y.
NEW YORK: 285 MADISON AVENUE
BOSTON: PARK SQUARE BUILDING
CHICAGO: PEOPLES GAS BUILDING
SANTA BARBARA, CAL.
LONDON: WM. HEINEMANN LTD.
TORONTO: OXFORD UNIVERSITY PRESS

Doubleday, Page & Co.
OFFICERS
F. N. DOUBLEDAY, President
NELSON DOUBLEDAY, Vice-President
S. A. EYERITT, Vice-President
RUSSELL DOUBLEDAY, Secretary
JOHN J. HESSIAN, Treasurer
L. A. COMSTOCK, Asst. Secretary
L. J. MCNAUGHTON, Asst. Treasurer

DOUBLEDAY, PAGE & COMPANY, Garden City, New York

Copyright, 1927, in the United States, Newfoundland, Great Britain, Canada, and other countries by Doubleday, Page & Company. All rights reserved. TERMS: \$4.00 a year; single copies 35 cents.

Q · R · S

(Trade Mark Registered)

RADIO TUBES ARE BETTER

Q · R · S

201A Type

\$1.75

Detector Amplifier

Q · R · S

Power tube

\$4.50

Audio Amplifier Last Stage
Only

Q · R · S

Super Detector

\$4.00

Q · R · S SPECIAL TUBES

Q · R · S

Voltage Regulator

Glow Tube

\$5.50

Q · R · S

Full Wave

Gaseous Rectifier

175 Volts D. C.

60 Mills

\$4.50

Q · R · S

Full Wave

Gaseous Rectifier

200 Volts D. C.

85 Mills

\$5.00

Q · R · S

Rectifying Slug

2½ Amp.

\$4.50



300 Volts D. C.
400 Mills D. C.

Q · R · S

High Voltage
Full Wave Gaseous
Rectifier Tube with
ionizer

600 Volts D. C.

100 Mills

\$6.00

The Pioneer 400 Milliampere Q·R·S Full Wave Gaseous Rectifier tube with ionizer.

The tube that makes possible the elimination of A, B & C batteries on standard 201A type receivers—Price \$7.00.

We will furnish without charge—charts and diagram for building five, six and seven tube sets using 201A type tubes and Power Tube—operated direct from the house current supply.

THE Q · R · S MUSIC COMPANY, *Manufacturers*

Executive Offices, 306 S. Wabash Ave., Chicago

Factories—Chicago, New York, San Francisco, Toronto

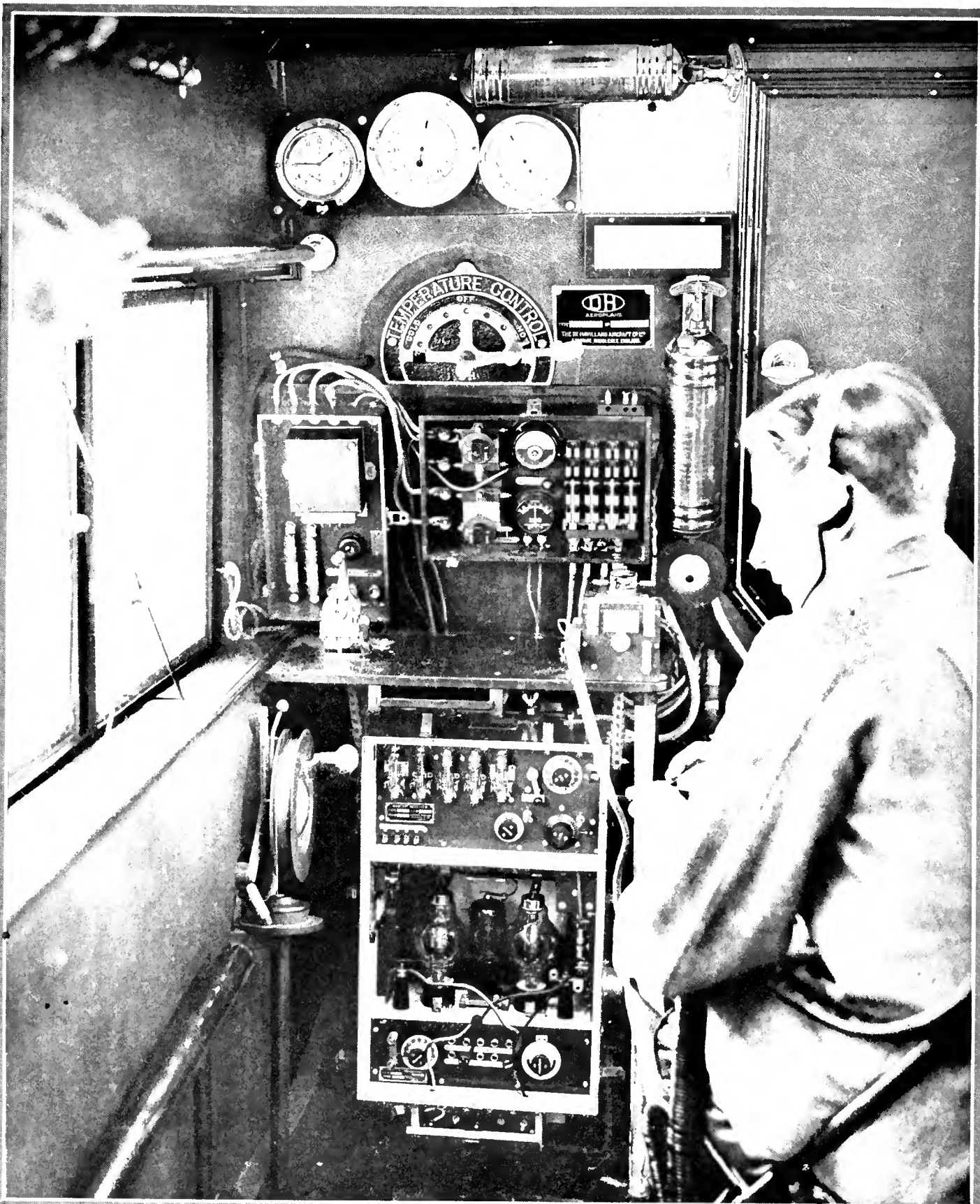

IN THE RADIO CABIN OF AN ENGLAND-EGYPT-INDIA AIRPLANE

Under the new international air regulations, a radio operator and mechanic is carried aboard passenger air liners. Previously the wireless apparatus was operated by the pilot and fitted in the cockpit. The 150-watt apparatus shown is aboard a De Haviland 66 Hercules multiple-engined machine on the England-Egypt-India air route. The reel for lowering the antenna is at the left

RADIO BROADCAST

VOLUME XI



NUMBER 3

JULY, 1927

The Aurora and Fading

A Report of Some Observations on the Relation Between Radio Signals and the Aurora Made During the Last MacMillan Arctic Expedition to Greenland and Labrador

By AUSTIN G. COOLEY

THE mystery of fading and freak radio conditions has been one of the most prominent problems in the science of radio since its earliest days. It has been observed in a general way that some relation exists between radio fading and other phenomena such as air pressure, temperature, humidity, aurora, etc., but no generally accepted hypothesis of evidence has been advanced for consideration that definitely ties these phenomena together.

Besides the studies made during the 1926 Rawson MacMillan Sub-Arctic expedition for the Field Museum of Chicago, were the efforts made by the writer to find a relation between the aurora and fading. As will be remembered, the *Sachem* (one of the two boats on the Expedition) was outfitted with radio equipment designed in the Laboratory of RADIO BROADCAST. The writer was the operator chosen to make the trip, and was thus able to make the studies which are outlined in this article.

Every effort was made to collect information that would prove valuable in determining what relation, if any, existed between aurora and radio fading. Owing to the lack of time and the limited amount of apparatus available, it was possible to collect only a fraction of the information that might be useful in the study, but sufficient was observed to point out a possible solution to one of the mysteries of radio fading.

During an early part of the Expedition, while on the coast of Labrador, mirages of ice and land caused considerable attention and comment. Commander MacMillan spent an evening telling of his experiences and observations on mirages to the members of the crew of the *Sachem*. He said that, if conditions were right, it would be possible to see mirages of objects half way around the world. This suggested the possible relation of mirages to short-wave radio transmission because radio and light waves are the same except for length. The shorter radio waves, which have a closer re-

lation to light, seem to behave in very much the same way as light in that they can be reflected or refracted so as to reach far distant parts of the globe.

A radio communication from the Expedition to RADIO BROADCAST commenting on this possible relationship, and telling of the mirages on the Labrador Coast, brought the following reply:

Greatly interested in your reflection idea. New York *Times* July 15 quotes Captain Rose of Steamer *President Adams* at 8 P. M. July 15 in Mediterranean Sea bound for Port Said quote Saw large field of floating ice cakes suspended above horizon and presently a number of small pieces drifted into view followed by a large one. The latter was so clear that we could see blue and green veins in the ice unquote Nearest ice field was 8000 miles away.

This news gave one member of the Expedition courage enough to tell a story he had heard about people in an Alaskan town seeing a mirage of an European city.

The mirages seen off the Labrador Coast formed very slowly. As a rough guess, the time averaged around five to fifteen minutes. They generally remained in position for a number of

hours. Because of this slow action, we did not suspect that there might be a connection with radio fading, but observations taken about a month later indicated that the occurrence of mirages was an important factor to be considered.

Except for the last few days, no unusual radio conditions prevailed while the Expedition was off the Greenland coast. Reception on short waves seemed to be excellent regardless of position with respect to surrounding land or mountains. During the last three or four nights, however, it was very difficult to establish communication with any of the amateur stations in the States. For long periods, practically no amateur signals came through. The weather conditions at first were such that it could not be determined whether aurora existed at the time or not, but the weather cleared up enough the night of sailing west from Sukkertoppen, Greenland, to allow us good vision of the skies. Strong displays of aurora were observed but no time was then available to make any studies. While crossing Davis Straits to Baffin Land, fading on short waves made communication very difficult as the signals generally faded in and out in cycles varying in length from five to fifteen minutes. Again, thick weather prevented thorough investigation.

It was not until the Expedition arrived at Saglek Bay, Labrador, that anything definite could be determined regarding the aurora. Fortunately the displays at Saglek Bay were unusually strong and the weather perfectly clear.

Here it was soon found that some association existed between the aurora and fading yet there were times when the signals were absolutely unaffected during strong displays. The problem resulted into one of determining just when and how the signals were affected in relation to the aurora. Having no information that would suggest what to look for, it was difficult to determine just what observations should be made. After watching the aurora and signals for a little over an hour, there appeared to be some

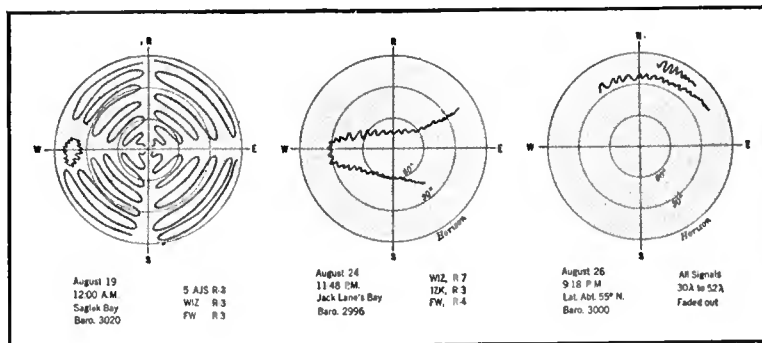

HOW THE AURORA WAS LOGGED

The observer is supposed to be situated at the center of the circle and if some aurora is noted in the northern sky at an angle of somewhat less than 30° with the horizon, then some lines to indicate it are roughly drawn on the sketch between the horizon and the 30° circle. Such conditions existed when the right-hand sketch was made, the effect on radio signals being noted below the drawing. The center sketch shows aurora of a somewhat different form while the left-hand sketch indicates that the sky was, at this particular time, completely covered with bands of aurora, while a small cluster was also seen in the west

relation between the location of the aurora and strength of signals but it was all very puzzling. At times the sky would be completely covered with aurora yet the signals came through nicely, while at other times, the signals faded out completely when only a very small amount of aurora was visible.

While at sea the night after this display at Saglek Bay, further observations were taken but under quite different conditions. The aurora formation was entirely different in that it formed in long bands on the northern horizon then moved across the skies to the zenith—at times the bands traveled on to the south until they reached within thirty degrees of the southern horizon before they faded out. The relation of the aurora bands to radio fading appeared very definite. When the bands were between ten and thirty degrees above the horizon, the signals coming from the opposite direction to the aurora faded out completely. When the bands were more than forty-five degrees above the horizon, the signals were not sufficiently affected that any difference could be determined between reception then and under normal conditions. The actual intensity of the aurora seemed to have little or no effect on the signals.

The magnetic storm accompanying the aurora display was observed by taking bearings on islands and then watching the compass. As the streamers passed overhead, the compass was observed to swing about eight degrees, but when the streamers were close to the horizon, no effect on the compass was observed. This information appears to be interesting in that the radio fading did not occur during those periods when the magnetic swing was the strongest.

The district in northern Labrador where these studies were made is known as the zone of maximum amount of aurora. Consequently, the opportunities for making investigations on terrestrial magnetism and radio fading are great in these regions. For good work, a complete line of apparatus is necessary, the most essential thing being some device for scaring away the mosquitoes. Labrador is also the zone of maximum amount of flies and mosquitoes! Preparations were made to measure intensity and direction of earth currents during an aurora display near Nain, Labrador, but it was not possible to stay ashore for longer than ten minutes at a time on account of the flies, despite the fact that head nets and oils were used for protection.

The magnetic storms continued and the weather remained clear for a number of days, so it was possible to observe the aurora at leisure. All the information we gathered checked nicely with that obtained during the first two nights.

Fading was watched on two wave bands; one from twenty to one hundred meters (15,000 to 3000 kc.) and the other from two thousand to eighteen thousand meters (150 to 16 kc.). Because of familiarity with reception between thirty-two and forty-eight meters, this particular band was given the most attention. While at Saglek Bay, a broadcast receiver was set up ashore for the purpose of receiving a special program being broadcast from WJAZ, Chicago, but it was not possible to hear any of the broadcast stations. Under normal conditions, the broadcast stations could be heard reasonably well, even in Greenland.

Before trying to account for the fading during certain phases of the aurora displays, it probably would be interesting to consider a few of the definite cases. It was found that the European commercial short-wave stations were the last to fade out, their direction being a little south of east. Generally, when they were received weakly, it was found that they were sending test signals or sending traffic slowly and each word twice, this indicating that they were also experiencing the fading effects. Station KEL, near San Francisco, generally came through even when all the other stations on short waves had faded out completely. This station was operating on a wave of about thirty meters and its direction bore about thirty degrees south of west. At no time was it noticed that KEL was having difficulty getting his signals through to his receiving station which was in a westerly direction.

The schooner *Morrissey* of the Putnam Expedition, which was about a thousand miles to the north of us, operated without difficulty in communicating with a station near Chicago. The *Morrissey's* signals were received with normal intensity on the Labrador Coast when the aurora was very strong in his direction but his signals faded out when the aurora was confined chiefly to the southern horizon.

No fading effects were noticed on wavelengths above two thousand meters. No static noises were

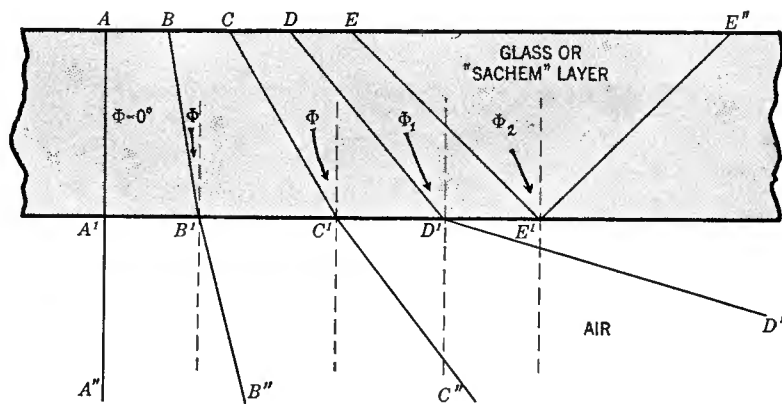

FIG. 1

noticed at all during any of the aurora displays and all was quiet except for noises caused locally aboard the ship.

THEORIES INVOLVED

THE physics of light seems to play an important part in the phenomena of radio wave propagation. In trying to account for radio fading it is best to consider first a few of the simple laws of reflection and refraction of light beams. When a light beam passes through one medium, e.g., glass, into another, e.g., air, the beam is bent or refracted. The amount of bending is a factor of the difference in speed with which the light travels through the two different mediums. The relative speeds of light in mediums are designated by their "index of refraction." The index of refraction of a vacuum is taken as unity. Glass has an index of refraction of about 1.6, and diamonds about 2.4. The "index of refraction" also varies with the wavelength. In the light and heat spectrum, the index decreases with the increase of wavelength. This has also been found to be true in the radio wave spectrum.

Fig. 1 shows how a light beam is refracted when passing through glass into air. The letters A, B, C, D, E, represent the sources of light beams. As the angle of incidence, ϕ , increases, a point will be reached where the ray will not pass into the air but will be totally reflected. The smallest angle at which total reflection occurs

is known as the "critical angle," and in Fig. 1 is some value between that of ϕ_1 and ϕ_2 .

Considering that radio waves are the same as light waves except for the difference in length, we may expect them to behave similarly. With mirrors it can be definitely shown that short radio waves may be reflected in the same manner as light waves. It has also been demonstrated that radio waves may be refracted as light waves are when passed through a prism or lens. The amount of refraction for radio and light waves is almost the same in some prisms.

A radio wave is known to follow two paths one along the surface of the earth and another into the higher atmospheres. Some of the waves taking the latter course appear to be reflected back to earth after they reach a certain height. The medium which causes this reflection is known as the Kennelly-Heaviside Layer and its height has been determined through the efforts of Dr. A. Hoyt Taylor and Doctor Hulburt to vary from 100 to 500 miles, depending upon the time of day and the season. The theory of reflection from the Kennelly-Heaviside Layer is generally accepted, so there is no need of considering it here in detail.

If a medium is placed over a receiving station so that the radio waves coming down from the Kennelly-Heaviside Layer are reflected, the receiving station will be completely shielded except

for that portion of the radio waves which travels over the surface of the earth. Assuming that such a shielding medium does exist under certain conditions, let us consider just what effects may be expected. Referring again to Fig. 1, assume that the ray E-E' is a radio wave and the medium, instead of being glass, is the lower shielding layer or reflecting medium just referred to as existing between the station and the Heaviside Layer. This reflecting layer may for the sake of convenience, be called the "Sachem" Layer. If the radio wave strikes so that ϕ is more than or equal to the critical angle, the wave will be totally reflected. In Fig. 2 it is seen that, if the lower surface of the layer is cut at an angle, the same wave will pass on through to the receiving station.

If the lower surface is cut so as to incline the opposite way, Fig. 3, the waves C and D will strike at an angle more than the critical angle and will not pass on to the receiver.

If such a layer as suggested above does exist, it is most likely that its surface will be irregular and probably appears as waves that continually move due to slight disturbances. Any such layer then would cause radio fading which would be somewhat in proportion to the index of refraction of this layer, since the critical angle is dependent upon the refractive index.

Before referring any more to the observations made on the Expedition, it is best to consider the theoretical possibilities of any such layer. The requirements are that the index of refraction of the layer be greater than that of the atmosphere below if we are to obtain the reflections shown in the diagrams. It is also necessary to prove that the Heaviside Layer is above the Sachem Layer and that the two do not coincide and are not the same thing. There is not enough data available really to prove either of these two points; the best we can do is to attempt to draw reasonable conclusions from what information we have to work with.

In regard to relative heights of the two layers,

the writer is guided by the work of Doctor Taylor and Doctor Hulburt and the studies made on the height of the aurora. The work of these two scientists appears to indicate that the Heaviside Layer at night on the Labrador Coast would be considerably over a hundred miles above the earth's surface. As will be mentioned later, it appears that the aurora occurs on the surface of the Sachem Layer. The aurora has been found to average about sixty miles in altitude.

The changes of refractive index at different altitudes cause light waves to be reflected and bent so objects at a distance may be seen. The images are known as mirages. The causes for the changes in refractive indices are variations in air pressure and temperature, but it stands to reason that the air pressure decreases with increase of height so we cannot expect to find in the upper atmospheres a layer having a higher refractive index than the air below unless some other factor than pressure has a control. From studies made with light it is found that the refractive index increases as the air gets colder. If there is a sudden drop in temperature in the upper atmosphere, we can plainly see that we will have the proper conditions for a reflecting medium that would reflect all waves striking at less than the critical angle.

At the irregular boundary line between the cold and warm air, the light waves are bent, or refracted, so as to give the wave appearance. With the air pressure as high as it is at the earth's surface, only a small change in temperature is necessary to produce these visible waves but, where the air pressure is less, a considerable change in temperature would be necessary to produce an appreciable effect. It was noticed that the fading effects that might be attributed to the Sachem Layer, only occurred when the air pressure was high. An increase of pressure at the line where the temperature drops would increase the possibilities of the existence of the Sachem Layer.

It is also to be considered that the surface of such a layer would be sharp since large temperature changes can occur in a very short distance. One often notices the sudden temperature changes in the air when driving in an automobile.

CHECKING UP THE HYPOTHESIS

THE investigations made on the Expedition appear to connect closely with the above hypothesis of the Sachem Layer in remarkable detail. Mirages and aurora appeared only as associated phenomena and not the direct cause of fading. From studies made, it appears that the aurora followed along the crest or high part of the Sachem waves. Because the waves were marked by the aurora, it was possible to tell just when signals would come through and when they would suffer reflection.

When the waves were very flat, the aurora appeared to fall from their crests into the troughs. This resulted in the entire sky being covered with aurora but, because the waves were rather flat, the radio waves were not subject to as much total reflection. Fig. 1 represents the case of a flat wave.

Since the inertia of the body of the Sachem Layer is very little, it is possible for the waves to travel at a very high speed. Judging from observations made in Labrador, it appeared that the waves traveled from five to thirty miles per minute. The major waves would undoubtedly be surfaced with smaller waves, as is the case with

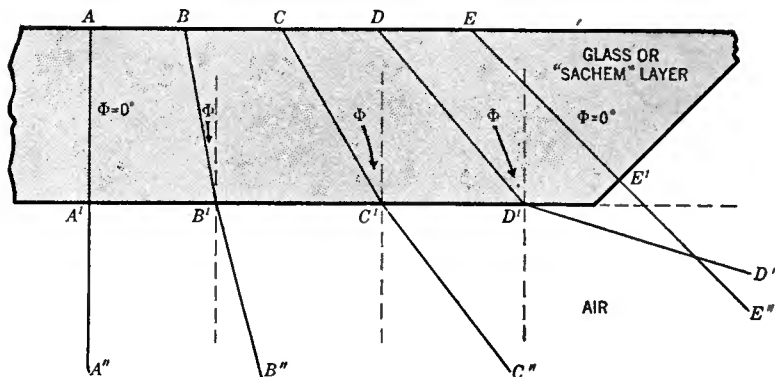

FIG. 2

ocean waves. The smaller, or minor Sachem waves, can cause additional fading that would appear more rapid.

It is to be noted that this Sachem wave hypothesis of fading takes into account the relation of temperature and humidity to the fading. When the temperature is high in the earth's atmosphere, a greater and sharper index of refraction will occur at the Sachem Layer. This will cause a larger portion of radio signals to be reflected so they will not reach the earth's surface. If the temperature is low, the change of index of refraction at the Sachem Layer may not be enough to cause any reflection even though the pressure may be high.

The humidity increases the index of refraction so fading would occur in a higher degree when the humidity is high. The effects of humidity on radio fading were given considerable study by Frank Conrad (8XK, Pittsburgh) and James C. Ramsey (1XA, Boston) when carrying on the first short-wave radiophone tests in 1922 on the sixty-meter band. They were thoroughly convinced that humidity affected fading.

It is also interesting to note that radio communication is chiefly affected in the north and south directions during aurora displays while land wire and cable communications are affected in the east and west directions, due to potentials generated in the earth probably by the swinging magnetic fields.

Vaudeville artists have been unable to determine whether the hen or the egg came first. With our present information it is difficult to say whether the aurora causes the Sachem Layer and waves or whether the Sachem Layer and waves cause the aurora. Probably neither is correct, but it seems certain that they occur at the same time and are dependent upon each other. The heavy air pressure on the surface of the earth has a direct relation to the Sachem Layer and may be

the cause of it. The Sachem Layer may produce the proper conditions so that, by means of the magnetic field revolving with the earth, high enough potentials may be produced to cause an electrical discharge along the Layer in places where the proper pressure or "critical pressure" exists. Such an electrical discharge would tend to put a load on the earth's magnetic field and distort it. This may be the answer to the swinging of the compass as the aurora bands pass overhead.

It appears that only a slight change of index of refraction is enough to refract a radio wave considerably. This may be accounted for by reflection of polarized waves but, to avoid confusion, a discussion on this point will be omitted.

As mentioned before, a change of pressure or temperature will cause the index change. The index also varies with different gases. A possibility exists that the change at the Sachem Layer may be due to a gas change. If this should be true, it is quite likely the gas responsible is nitrous oxide.

In 1912, Mount Katmai in Alaska erupted. A large amount of sulphur dioxide gas escaped and was so strong at Cordova, Alaska, about 400 miles away, that enough dissolved in the rain to bleach cloth. Radio communication was impossible for a number of days, even over a distance of a few miles. Apparently even the earth waves suffered such reflection that they were unable to travel any distance from the transmitter.

Another case of the apparent effect of gases was noticed by the writer when operating two receiving sets, one from a loop and the other from an antenna subjected to smoke from a chimney. Considerable fading from a local station was noticed on the set operating from the antenna while the loop set operated without any noticeable change in signal strength.

It is hoped that the information and hypothesis advanced in this article will encourage other investigators to work along lines to prove or disprove all that is claimed here, so that, by a process of substitution and elimination, more of the factors influencing radio fading will soon be known.

The writer wishes to thank Dr. J. H. C. Martens, geologist of the expedition, for his help in obtaining information on the atmospheric conditions; Commander MacMillan for his helpful suggestions; and Commodore Rowe B. Metcalf who built and financed the schooner *Sachem*.

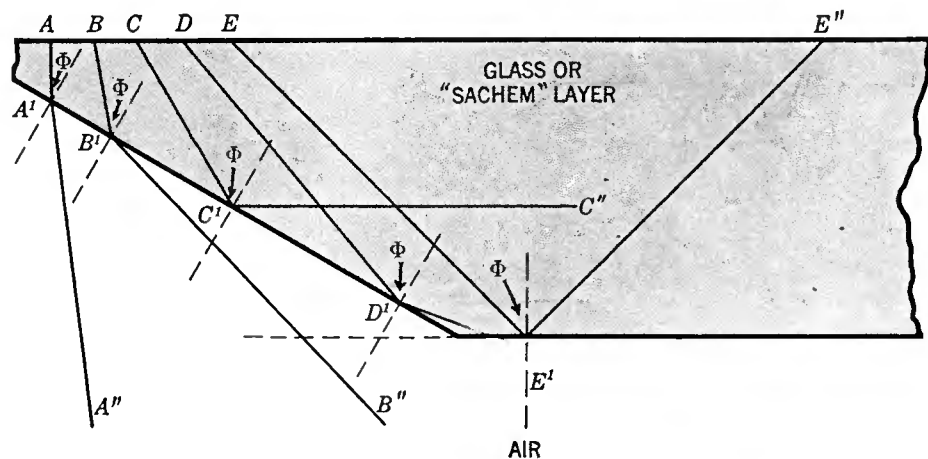

FIG. 3

The March of Radio

News and Interpretation of Current Radio Events

What the Radio Commission Is Accomplishing

THE Federal Radio Commission has proceeded to its labors with caution and moderation. Its first step was to clear of American pirates, the six usurped Canadian channels. Next it cleared the various channels of those stations which elected to occupy two broadcasting channels rather than one, by restricting allocations to channels exactly ten kc. apart. It definitely decided against broadening of the broadcast band. It opened up the lower frequency end of the amateur band for experimental purposes. It adopted a policy of temporary licensing of broadcasting stations, reserving the option to change the assigned frequency or power of any station at any time or to revoke its license at will. This permits the Commission to arrive at the ultimate lineup of stations by a careful process of evolution rather than by a dangerous upheaval.

The Commission has made a start in cleaning up the New York and Chicago situations by assigning all stations to channels at least twenty kc. apart, thereby minimizing heterodyning and cross talk between stations in the same area. Some incomprehensible broadcasters had actually been using channels only five, three, and two kc. apart from other stations in the same area, thereby successfully eliminating all listeners from both channels. The ultimate plan is to require at least a fifty-kc. separation between stations, allowing the simultaneous operation of twenty stations in the same area.

Fifty-kc. separation, although a vast improvement, still means a nearly complete air blanket by local stations in New York and Chicago for all but the most expensive radio sets. It is far from the ideal broadcasting situation. The next step should be to eliminate a few more excess ether polluters, of which there are many in New York and Chicago, whose demise will be loudly applauded by all listeners. For example, there is a group of anaemic New York stations, comprising the last word in program mediocrity,

which are linked up in a chain, thus inflicting their hopeless hours upon the listener at three places on the dial instead of one. There is no excuse for a chain of stations serving the same area except when the combination is a temporary one, linked only for program events of transcendent importance, such as presidential addresses or national election returns.

A further reduction in the number of channels required by New York and Chicago can be effected by requiring the splitting of time on the part of stations so limited in their ability to serve the public that they can afford to broadcast only during the prize hours of the evening. A station broadcasting only in the evening is not entitled to an exclusive channel. It should be limited to perhaps two evening programs a week. That would help to cut down the unpopular small fry.

Radio Freedom of Speech Impossible

IF WE omit those who make a profitable profession of agitating for freedom of speech, the radio audience is little exercised about this subject. We have examined several hundred replies to the ques-

tionnaire published in the May issue which, at this writing, are still being received from our readers in great numbers daily. Those who answered the questionnaire—and they are from all over the country—were emphatic and practically unanimous in their disapproval of the religious stations. In the Chicago district, another marked trend is indicated by the many requests for the elimination of WCFL and WJAZ. The feeling against WJAZ is particularly strong. Apparently undermining the Department of Commerce's legal status has caused distinct reaction. Other parts of the central west take particular delight in urging the immediate extinction of KFNF, KMA, and KTNT because of their blatant direct advertising. We regret that a few of our readers have even suggested diabolical forms of punishment for the owners of these stations, apparently a subconscious influence of previous incarnations, many being reminiscent of the Spanish Inquisition. A host of lesser stations come in for their share of blackballing, but the expressions toward them are not nearly as consistent or as emphatic as those directed against religious, direct advertising, and propaganda stations.

The old established stations, both of the chain and, we are glad to say, the better independents, rank highest among those stations which listeners wish retained. In our question, "What distant stations do you wish retained?" the percentage within range of KDKA putting that station first, is striking. The regularity with which KDKA, WEA, WGY, and WJZ appear in that order is also remarkably consistent, while KYW, WGN, KPO, and KFI are strong in the approval of listeners within their respective ranges.

For making this statement of fact, we shall, no doubt, receive one or two letters from rabid demagogues, inquiring how much we were paid by the R. C. A. or the N. B. C. for mentioning the obvious superiority of some of their affiliated stations.

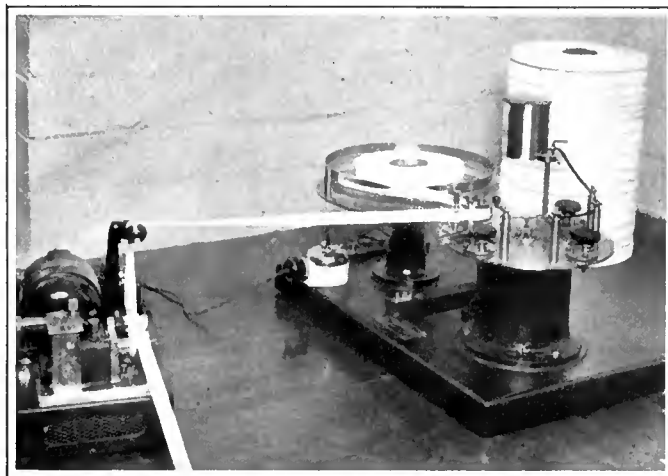

"BEAM" WIRELESS SERVICE DIRECT FROM ENGLAND TO AUSTRALIA

Messages are now sent at an average rate of 100 words per minute between London and Melbourne. The English receiver at Skegness uses the Marconi UG2 high-speed automatic syphon recorder shown in the illustration. An automatic tape puller is at the left

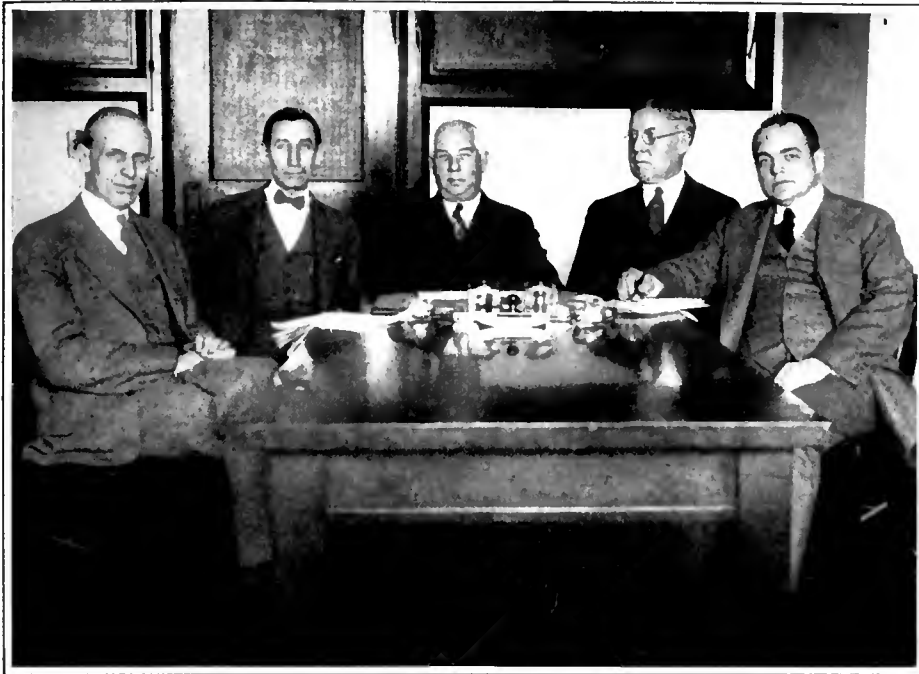

THE GOVERNORS OF THE UNITED STATES ETHER

The Radio Act of 1927 became law on February 24th. Its provisions did not go into force until two months later. From the time the Commission was appointed, it has been very active. In March, public hearings were held in Washington, giving a reliable cross section of opinion and suggestion for dealing with the broadcasting problem. The Commission has cleared the Canadian channels, reduced power of stations in residential districts to 500 watts, reinforced the 10-kc. separation between stations, and already reduced the total number of broadcasters from 732 to approximately 660. From left to right: H. A. Bellows, E. O. Sykes, W. H. G. Bullard, J. F. Dillon, O. H. Caldwell

In response, we regret to advise that, to date, we have not been rewarded in any way. We would like particularly to publish in full a scurrilous letter along these lines, sent us by a certain Mr. O'Hara of Nebraska, because it is representative of the type of letter which sometimes follows favorable mention of the pioneer broadcasting stations. The ratio of letters, endorsing our stand for a drastic cut in the number of stations, to these rabid letters, accusing us of being bribed by the monopoly, is far better than two hundred to one. Mr. O'Hara's occasional profanity and excessive wordiness make it impossible to quote him in full, but these few words indicate his trend of thought:

You want to see 500 stations eliminated and these 500 are to be the ones you New Yorkers and the chain don't own fine business for you, then you and your pals can get \$4500.00 per for the use of your stations for advertising and you will have no competition so you can put your price up and make 'em pay it because there won't be any other stations. Well old dear lets see you put that over and get away with it. The half has never been told in this radio game yet and the dear public are going to be told a few things during the next few months that may make some of you fellows think this is a cruel old world. You know that is what Donahue and Sinclair both think this miserable U. S. Govt. has just treated them terrible. You fellows are not kidding the dear publick as much as you think you are. You and your gang want to hog the radio broadcasting, not because you are so interested in giving the dear people high class programmes and by the way just what do you mean by high class programmes? Some cigarette smoking female Dago or Russian warbling in upper C till they drive all the dogs in the

neighborhood crazy. If that is your idea of a high class programme and judging from the programmes we hear over WEAf it is just keep them in the cultured and protected east will you.

We inflict this twaddle on our readers to make certain that few, if any, agree with our correspondent. The suggestion that these columns are subsidized is silly;

what we endeavor to do is to promote the good of radio as a whole. We are using what influence we have to bring about the conditions which the majority of listeners want and should have. Only by following such a course can we hope to continue our steady growth. We welcome expressions of opinion of our editorial stand and hereby take the opportunity to thank publicly the hundreds of readers who have written us favorably during the last few weeks.

We continue unhesitatingly to urge further reduction in the number of stations until the total falls to 225 or 250 powerful and capable broadcasters in simultaneous operation. We hope for a spirited competition in program attractiveness among independent, well organized, and well financed broadcasting stations. We are in favor of eliminating a great number of small stations so that we may have more great stations. This is our stand because it is sound common sense and because it is the expressed wish of a majority of our readers.

What Stations Shall Be Eliminated?

THERE is no excuse for the existence of a station which serves only a special and limited interest — to the exclusion of general educational and entertainment services to which the broadcasting band should be devoted. Since broadcasting facilities are limited because there is room for only so many stations on the air, some form of selection must be applied. That may be censorship; call it what you will. "Freedom" of the air is impossible because more wish to broadcast at the same time than the ether will accommodate. That means restriction and restriction is not freedom.

The first stations which must go are the

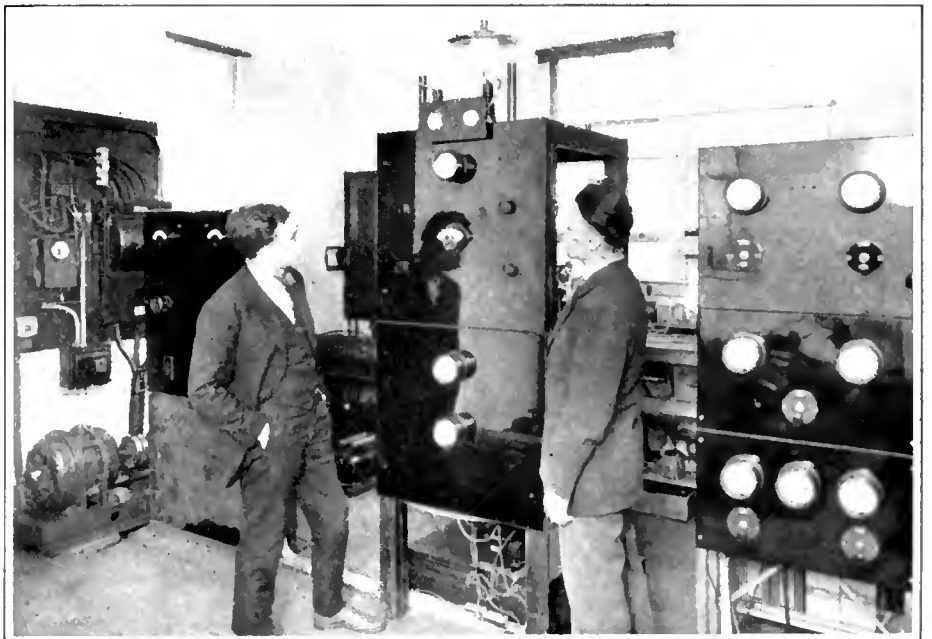

THE CROSLY SHORT-WAVE BROADCASTING UNIT AT CINCINNATI

All the w.l.w. programs radiated on the standard broadcast frequency of 710 kc. (422.3 meters) are now also simultaneously broadcast on 5760 kc. (52.02 meters). The power is 250 watts. On the left is Russell Blair, the Crosley engineer, who built the set. On his right is Joe Whitehouse, chief engineer of w.l.w.

direct advertisers because the public vigorously resents their existence. A broadcaster serving the private purposes of a harness maker or a seed salesman is not serving the public.

The next group which must go consists of stations representing perfectly legitimate special interests, but using the entire time of a private broadcasting channel for the benefit of only a fraction of the audience and for only a small part of the total hours of the day. Labor groups, sectarian religious appeals, socialism, Mormonism, atheism, vegetarianism, and spiritualism may require the use of microphones, but they do not require exclusive channels. If goodwill advertisers were as narrow minded as the religious and "ism" interests, they would demand separate and private channels also. Within a few evenings, we recently heard the La-Salle, the Willys Overland, and the Studebaker concerns broadcast through the same high-grade station. But suggest to a religious or educational group that they use a single station coöperatively with others of a different creed or line of thought and they wail that you discriminate against their interests.

There is need for a more generous spirit on the part of the smaller broadcasters, leading toward a healthy and desirable combination of stations with consequent increase of audiences, improvement of reception, reduced maintenance cost, and better program standards. There is no shortage of microphones to present any worthy cause. Broadcasters, accused of the most sordid commercialism, do not refuse the gentlemen of the clergy and educators free use of their broadcasting facilities. If the Radio Commission will let solely the interest of the listeners, rather than the private desires of the broadcasting station operators, determine their ultimate solution of the broadcasting problem, there will be a continued decrease in the number of stations on the air until they are less than 300.

It is unfair to condemn small broadcasters as a whole because here and there are one or two fine exceptions which have shown a far-sighted spirit of coöperation. We spoke to the owner of a small station in Newark which did not increase power or change wavelength through the radio dark ages, in spite of the fact that two pirates completely hedged in its programs. After such maltreatment, however, the station's owner expressed a willingness for the good of radio to discontinue broadcasting if all small broadcasters were to be treated in the same way. Another example for small broadcasters is that set by G. S. Corpe, who has been in radio since 1909, and who wrote us recently as follows:

The writer owned KUY, one of the first three

or four stations on this Coast. It was a popular station, too, back in 1922; but two weeks after the Los Angeles Times—KHJ—installed a real Western Electric set, we discontinued KUY. Why? Because we felt that with inferior home-made equipment and a limited amount of talent in a small town, we were hurting radio by continuing rather than helping it. Apparently, there are some hundreds of broadcasters in the last year who have not been suffering from any such modest and retiring attitude.

But the majority of small broadcasters feel that self-elimination or combination is unthinkable. In the last analysis, there is but one choice. Broadcasting may remain stationary in comparative mediocrity and the radio industry will be thereby practically paralyzed, or the radio listener may be



A RADIO BEACON FOR SHIPS

Operating directly off the ship's a. c. mains. It has two $7\frac{1}{2}$ -watt tubes in parallel tuned to 352.7 kc. (850 meters). The signal—i. c. w.—is a series of one-second dashes for thirty seconds, followed by a silent period of thirty seconds. A single-wire antenna about 50 feet long is used, independent of the ship's antenna system. The beacon on shipboard enables ships using a radio compass to exchange radio bearings over a distance up to twelve miles. Naval radio compass stations on both coasts and on the Great Lakes now provide bearings to ships at sea on 374.8 kc. (800 meters)

served by substantially reducing the number of stations, encouraging capital to spend huge sums on improved broadcasting by reason of the greater audiences of the remaining stations. The axe must be applied either to the broadcasting stations or to the radio industry, and the Radio Commission is choosing between the two. Happily, it is bending its efforts toward station reduction, a saving grace for the radio industry; our only fear is that it will not go nearly far enough in the right direction.

Unnecessary Duplication of Radio Standards

EXPENSIVE trouble is being stirred up in the radio industry by the toleration of two separate organizations busily engaged in setting up standards. Standardization is vital but the establishment of two sets of standards is figurative suicide. We cannot be concerned with the respective claims or purposes of the organizations involved. Both groups are meritorious and well intentioned. In a previous issue, we stated that the radio industry was shortsighted in tolerating two sets of standards and were taken to task by one of these organizations for so doing. Its spokesman claimed to speak for the only representative organization. Whether his statement is true or not, the fact remains that two sets of standards are being drawn. We repeat that this is folly which in the end will be very costly. The rival organizations may differ entirely in purpose, membership, policies and what-not, but in the preparation of standards at least they should function as one organization.

Why Important Events Can't Always Be Broadcast

AN EDITORIAL in the New York *Evening Post*, entitled, "Radio and the Press," points to a serious evil of the broadcasting system, unavoidable under its present economic structure. The Butler-Borah debate, it pointed out, although of great public interest, could be heard only through two small New England stations, both of which were surrounded by interference from stations who had jumped their wavelength. None of the big broadcasting stations, because of commercial commitments, were in a position to offer their audiences this desirable event. The newspapers, on the other hand, were in a position to give the report of the debate plenty of space, hampered by no limitations as to cost of printing and paper, reportorial representation, and wire transmission; nor did the publication of this news require the sponsorship and capitalization of a commercial organization.

While the commercial broadcasting rate of even the best stations is necessarily limited at this stage of the game, a large proportion of their time must be given to commercial features which cannot, for very vital reasons of revenue, be set aside whenever an interesting broadcasting event heaves into sight. If the individual audience of stations be tenfold, however, the increased revenue thereby gained would make it possible to set aside revenue pro-

ducing features more freely in favor of such desirable news features.

Radio Reception Is No Longer Seasonal

A STATEMENT by the National Broadcasting Company to the effect that there is no summer seasonal slump in broadcasting program quality is supported by a list of regular weekly features which continue throughout the summer. The program fare of the listener is remarkably well sustained throughout this period and it is a pity that the tremendous prejudice against summer reception has been built up. This prejudice is a heritage of the days of headphone reception when even slight static impressed directly upon the ear drums of the listener caused acute discomfort. With modern pick-ups by loops or very small antennas, and up to date sound radiation through power loud speakers, reception from near-by and local stations is entirely satisfactory twelve months of the year. The seasonal usefulness of a good radio set is no less than that of a closed automobile which is out of service only for blizzard or hurricane for a few hours each year. Radio must make way only for thunderstorms. The only static eliminator required is the encouragement of the use of small pick-up devices, either loops or small antennas, rather than the all-too-long antenna frequently employed.

Radio Control Unsettled in Australia

AUSTRALIA is in the midst of an argument about the regulation of broadcasting. The Naval Board desires to shift the broadcast band from its present 300 to 400 meters area (1000 to 750 kc. area) up to the 800-meter (375-kc.) region. Any attempt to regulate broadcasting from any constricted point of view always works hardship on the listening audience. The Australian Naval Board's proposition means that special receiving sets of higher cost will have to be made and these sets will not be able to pick up foreign broadcasting which may some day be within their range.

Where Are the Listeners' Organizations?

OUR comments in a recent issue regarding the general ineffectiveness of most broadcast listener societies caused a number of irate "executive" secretaries to uncover the bushel which hid their feeble light. Some of these accused us most petulantly of going out of our way to disregard their frantic efforts to form a broadcasting listener organization. We are not, however, guilty of any prejudice or oversight, since none of them have, through public statements or by public attention gained through constructive activities, come to our notice previously. We hope that the spirit of service to the



© Bell Telephone Laboratories

THE LATE IRVING BARDSHAR CRANDALL Irving Bardshar Crandall, a member of the technical staff of the Bell Telephone Laboratories and an authority on the telephonic transmission of speech and methods of recording it, died on April 22, 1927, at the age of 36, in New York. He was graduated from the University of Wisconsin in 1909 with the degree of Bachelor of Arts and received the degree of Master of Arts from Princeton. In 1916, three years after he had become associated with the Bell Telephone Laboratories, Princeton made him a Doctor of Philosophy. At the time of his death, Doctor Crandall was engaged on important experiments. He recently published a book, *Vibrating Systems and Sound*, and he had previously written many monographs on the scientific aspects of speech, analyses of its mechanisms, and methods for its transmission and recording. He was a Fellow of the American Physical Society and the American Institute of Graphic Arts

listener, which should animate the proponents of any listener organization, will be sufficiently obvious to cause large numbers of radio folk to flock to their standards so that at least one of them will ultimately become a powerful and influential organization. The policies of bona fide societies should be actually shaped by the membership itself and not by the dictation of their handful of founders. Too often, however, are new organizations the figment of the imagination of a professional executive secretary who sees in them a great opportunity for profit. Whether this is the case is easily determined by examining the method by which the officers are elected and by determining to what degree the individual member has a real voice in shaping the policies.

The most promising organization from which we heard was the United States Radio Society, claiming 5000 members in and about Cincinnati, Ohio. Fred G. Gruen, President of the Gruen Watch Guild, is the principal source of encouragement and funds for this organization, and he is putting much effort into building up something which is to give form to the listeners' desires in an unmistakable and influential way. We have not had opportunity to examine the constitution of the organization but do know, in the person of Mr. Gruen, that it has intelligent and unselfish leadership to commend it.

The Frequent Misuse of the Word "Broadcasting"

THE word "broadcasting" is frequently used in newspaper reports in referring to the dissemination of information through the regular radio telegraph channels. For example, it was recently announced that the Navy Department and the Weather Bureau in cooperation are broadcasting special weather information to aviators at 10:30 A. M. and 10:30 P. M. daily. The frequency employed is 8030 and 12045 kilocycles (37.24 and 34.89 meters). Eleven naval short-wave stations, well located, are used for the purpose. Obviously this is broadcasting in the sense that it is sent out in all directions by radio. However, the use of the term "broadcasting" should be confined to programs radiated in the broadcasting band. By so limiting the scope of the word "broadcasting," much confusion in the meaning of newspaper stories will be avoided.

PROBABLE PROGRESS OF TELEVISION

THE stimulation of inventions due indirectly to the growth of broadcasting appears to be rapid. The first important contribution of scientific progress engendered by broadcasting is the application of vacuum-tube amplification to phonograph recording and reproduction. Now comes high-grade loud speaker entertainment to accompany motion pictures, a decidedly important contribution, particularly for small communities which have had to content themselves with second rate mechanical accompaniment or quite incompetent musical groups. The educational possibilities of the combination of loud speaker and motion picture are perhaps even more important although less spectacular than the entertainment aspects. The next step is to link the motion picture with radio transmission to give us television, a process already hatched in the laboratory incubator. Most people imagine television as a means of enabling them to see the radio artists perform in the studio, a privilege, we are frank to say, often of doubtful value. More than likely, the visual program broadcast for general reception will lean heavily upon the motion picture studio for its source. The improvement of the phonograph and the loud speaker at the moving picture theatre is accomplished by the use of radio developments with but slight adaptations. Television, on the other hand, will need much research before it is within range of home use. Considering the speed with which our laboratories work, stupendous as the problems yet to be overcome are, it may be a matter of only two or three years before you will be buying television receivers as a part of your radio equipment.

TWO ANNOUNCEMENTS BY THE WESTINGHOUSE COMPANY

THE transmission of power by radio has frequently been made the subject of public demonstration during the last few years. The most recent announcement comes from Dr. Philips Thomas of the Westinghouse Company. He utilizes a high-frequency transmitter, a straight Hertzian antenna, and a metal screen to obtain the beam effect. The radio-frequency output is approximately thirty-five watts and, by its means, lamps are lighted from a distance of ten to fifteen feet. It seems that the transmission of power must await some important new dis-



L. S. BAKER

New York

Executive Vice President Radio Manufacturers' Association. A special statement for RADIO BROADCAST:

"The question of whether or not the listener keeps his set in operation, tuned to his favorite station, is the keystone of the entire radio industry. Without trustworthy sets, good broadcasting is of no avail; without good broadcasting, the best set made is nothing more than junk.

"In recognition of this phase of public opinion which joins the two gigantic divisions of the radio industry and makes what are otherwise totally independent divisions entirely interdependent one upon the other, the National Association of Broadcasters and the Radio Manufacturers Association have joined hands by consolidating personnel, in an effort to keep all phases of the industry in constant liaison with each other."

coveries before we get beyond the technique of the average amateur "glow" wavemeter.

At about the same time, another Westinghouse engineer, D. D. Knowles, demonstrated his light-sensitive vacuum tube relay which does with light and shadow what our radio tubes do with radio-frequency currents. One billionth of a watt of input light energy is sufficient to start a current as high as twenty-five milliamperes flowing through the tube which can, in turn, be magnified sufficiently to control an electric power system of any size. Thus it is quite possible by the use of this relay for a passing shadow to turn on the lights of a city, start or stop a railroad train, or move a battleship. The automatic turning on and off of street lamps at sunset and during dark storms is a valuable service which, accomplished automatically, may result in the saving of millions of horsepower annually.

THE PATENT SITUATION

THE patent examiner rejected claims of an interference under design patent 72,261, issued to M. C. Hopkins. Hopkins contended that the Atlas loud speaker was an infringement of his design patent. The patent examiner stated that merely to place a cone unit in the base "would not require an exercise of the inventive faculties. It would be regarded as a mere assembling of the elements which are old in the art of making radio loud speakers."

The Patent Office reports the following suits and decisions: Patent No. 1,586,308, J. A. Victoreen vs the Radio Art Company, decree pro

confesso and injunction granted; 1,616,207, J. W. Wardell vs. Utah Radio Products, suit filed February 28.

The Latour Corporation has begun suit against the Charles Freshman Company of New York and the Zenith Radio Corporation of Chicago. The latter company has been licensed by the Radio Corporation and consequently the suit represents a test to determine the relative strength of the R. C. A., Hazeltine, and Latour patent groups.

The Splittorf Bethlehem Electric Company, the American Transformer Company, and the Crosley Radio Corporation, have joined the growing group which is licensed under the Radio Corporation patents.

A recent decision in the Exchequer Court of Canada respecting the Alexanderson radio-frequency tuning patent and the neutrodyne system, was favorable to the former. The contenders were the Canadian General Electric Co. and the Fada Radio Corp. Ltd. of Canada.

The Month In Radio

THE Hudson River Navigation Corporation is replacing its orchestras aboard the night boats, plying between New York, Albany, and Troy, with the highest grade of power radio equipment. The principal problem has been to obtain receiving sets sufficiently sensitive to overcome the dead spots created by ore deposits in the Catskills. This apparently has been achieved by three existing radio equipments, while an additional factor of safety will be provided by the fact that the amplifier system may be actuated by a high grade phonograph equipment to alternate with the radio programs.

A COMPANY has been formed in Africa to take over the bankrupt South African stations under the protection of a government monopoly for a period of five years. Stock will be offered to the public. The interests backing the plan are in control of the most important South African theatres and they promise better programs which should discourage the extensive evasion of license payments, the reef on which the original broadcasting plan was wrecked.

DR. A. HOYT TAYLOR, of the Naval Research Laboratory, states that station 2XS of the Radio Corporation of America, which theoretically should be inaudible at distances between two hundred and six hundred miles because of the skip distance effect, is nevertheless clearly heard in this so called area. Oddly, the much talked of skip distance influence does not, in this instance, follow any of the prohibitions laid upon it by radio observers.

THE Radio Corporation of America announces an improvement in its photographic reproduction system which accomplishes a ninefold enlargement of the picture received by radio through a new and ingenious method of printing the radio picture. Instead of putting a light beam on the surface of the sensitive paper, a special photographic paper is used upon which heat rays have the same influence that light waves have on the ordinary photographic paper. A jet of hot air is blown on the newly developed paper, making a black mark. A second jet of cold air, controlled by the radio signal, intercepts the hot air wave. The result is a more rapidly produced, clear print, nine times as large as one



C. P. EDWARDS

Ottawa

Director of Radio, Dominion of Canada:
"Broadcasting in Canada is indirectly paid for by the broadcast listener himself through the Canadian licensing system, whereby the owner of every radio receiving set must take out a license, for which he pays an annual fee of \$1. For the fiscal year ended March 31, 1926, the proceeds from broadcasting license fees of all classes amounted to \$139,742.40. "In only one case is any of these funds used to assist in the support of a broadcasting station. Station CKY, Winnipeg, owned and operated by the Provincial Government of Manitoba, has entered into an arrangement with the Dominion Government whereby it enjoys a virtual monopoly of broadcasting in that Province, and fifty cents out of each dollar license fee collected from residents of the Province is paid to the Provincial Government to assist in maintaining the station."

made by light rays. It is such ingenuity that encourages us to predict practical television somewhat sooner than the scientists, steeped in the details of the problem, are willing to grant as a possibility. Incidentally, the transmission of photographs by wire has recently been supplemented by three-color service.

OBSERVERS at the recent demonstration of television at the Bell System Laboratory in New York stated that they sometimes observed two or three images reproduced in the background which appeared much as do the ghostly figures in spirit photographs. The engineers state that these "ghosts," which have only a fraction of the intensity of the main picture, are caused by signals which take a longer path through the atmosphere than the main incoming signal. In the reception of music, we have similar lag which expresses itself in the senses as indefinable distortion. Television may pay its debt to radio development by the spectacular way in which it will reveal the hidden causes of distortion in radio reception.

A DEPARTMENT of Commerce report states that there are 49.5 radio sets per thousand inhabitants in England. Sweden is the second European Country with 40.1, Austria, third, 37.8; Denmark 25.3, Germany 22, Norway 15.5, Czechoslovakia 12.9, Switzerland 12.8, Netherlands 7, Belgium 3.14, and Finland 3.1. No figures for France and Italy were reported.

A Low-Cost Battery Charger

Something About a New Raytheon Rectifier Tube Which Is Remarkably Efficient—A Home-Made and Compact 2½-Ampere Charger

By JAMES MILLEN



COMPACT AND RUGGED

This is the full-wave charger unit manufactured by the National Company, Cambridge, Massachusetts, and which employs two of the new "A" tubes described in this article. The circuit diagram of this charger is shown in Fig. 6

STORAGE batteries, the source of direct current for lighting the filaments of the tubes in a radio receiver, are just what their name implies; they have the property of storing up electrical energy in a chemical form within their cells, and when called upon to do work, discharge this energy by virtue of a chemical action which takes place inside the battery. As the current is drawn out of the battery, the nature of the plates and electrolyte which go to make up the cells of the battery, change their chemical character, and finally reach a point where it is not wise to make further current demands upon them. In this state, the battery is said to be discharged and it becomes necessary then to reverse the chemical action so that the plates are restored to their original state of usefulness.

This requires that a direct current be passed back through the storage cells, and our most convenient source of supply for this work is the energy to be derived from the house lighting circuit. However, in most cases, this energy is in the nature of alternating current and as such is unsuited for *immediate* use. The reason for this is that the current flows first in one direction and then in another direction, these changes occurring, in the case of a 60-cycle current, 120 times per second.

The job, therefore, is to employ a device which will make use of these alternations and provide a series of pulsations delivering current all in one direction. This device is termed a rectifier, and may be obtained in many different forms. Some, such as the electrolytic, depend for their operation upon chemical action. Others, such as the vibrator or magnetic type, depend upon a set of mechanical contacts which shift every time the alternating current reverses. Still others, such as the Tungar, depend upon the unidirectional conduction of the stream of electrons emitted by an incandescent filament in vacuo. All have their advantages and disadvantages.

Perhaps the ideal rectifier would consist of a piece of low-resistance wire with the property of conduction in one direction only. The recent perfection of a rectifier which approaches somewhat closely this ideal is what brings us to the main topic of this article.

Working under great handicap in his small laboratory just outside of Paris, a French physicist, M. Henri André, developed the forerunner of a new rectifier "tube," one of which is shown in a photograph on this page. But what could he do with his device? He did not have the facilities or financial backing so essential in order to complete his work and carry his idea to a finished and commercially



THE NEW 2½-AMP. "A" TUBE

practical state. Then radio stepped in, in the form of the research department of the Raytheon Company, specializing in the development and manufacture of rectifying devices for radio use. M. André came to America where with most complete laboratory facilities at his command and with several physicists and engineers to aid him, it took but a year to reach the long sought goal. A highly efficient, inexpensive, rugged, compact, and long-lived rectifier element, encased in a small steel tube hardly three inches

long and less than an inch in diameter, was the fruit of his long labors.

As this new rectifier cartridge is now on the market, it is the purpose of this article to give a brief description of its theory of operation, together with some data on the design and use of a battery charger in which the tube is employed as the rectifying medium.

A rectifier as we understand it, is a device which offers great resistance, or opposition, to the flow of current in one direction and little or no opposition to the flow of current in an opposite direction. The more completely the rectifying device prevents current from passing in the one direction, and the more easily it permits current to flow in the opposite direction, the more desirable is its use as a rectifier. This new rectifier very admirably fits in with these requirements, for it involves a metallic conducting path with an oriented junction at one point which exerts very little effect when current flows one way, but which effectively opens the circuit when current attempts to pass in the opposite direction.

There is much yet to be learned in regard to metallic conduction, and the behavior of electrons in solids is not at all clearly understood. Hence a clear explanation of the exact nature of this oriented condition is indeed difficult. However, we may quote from a report by Dr. V. Bush, of the Massachusetts Institute of Technology, as follows: "All materials contain electrons distributed in orbits about the nuclei of atoms. When conditions are such that electrons may with ease pass from an orbit about one nucleus to an orbit about an adjacent nucleus a motion of electrons through the material is readily produced and we have an electrical conductor. Metals have this property in large degree and are hence good conductors. When two metals are in contact a similar interchange of electrons ordinarily takes place between the adjacent atoms of the two metals, and conduction readily occurs in the two directions. A proper choice of metals in the presence of a suitable agent, however, may set up a condition in which this property is oriented or unilateral. Briefly this occurs when electron excursions of one metal are much extended in the presence of the agent, while the excursions of the other are inhibited. In this condition the far extending electrons readily pass to the opposed metal and conduction occurs, while for a potential in the other direction

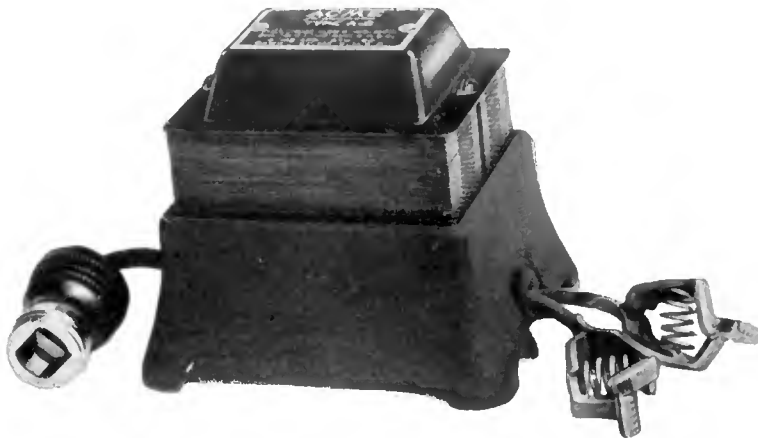

EMPLOYS THE NEW "A" TUBE

A commercially made charger employing the new tube described in this article. It is a product of the Acme Apparatus Company, Cambridge, Massachusetts

there is no overlap of orbits, and the device insulates."

In the new "A" rectifier, as this new development is called there are two metals—an anode of pure silver connected to the casing, and a cathode of a porous alloy connected to the central projection, brought into contact on the inside. The porous cathode contains in its interstices a non-conducting agent which has free access to the junction between the metals. The presence of this agent preserves the junction in an oriented condition, but the actual conduction is through the metals themselves. It not only creates the oriented condition, but preserves this function despite much abuse in the form of rough handling and usage.

Due to the fact that the conduction is metallic, the internal electrical resistance of the rectifier cell, and the power, or $I^2 R$ losses in the cell are exceedingly low, and thus its efficiency is quite high. As will be seen from Fig. 1, the efficiency of a charger employing the new tube is in the neighborhood of 60 per cent. When compared with existing types of chargers, this, as charger efficiencies go, is unusually high. Aside from the saving in power consumed, which may amount to as much as from \$6.00 to \$10.00 a year, the higher efficiency of a charger of this type permits it to be constructed from exceedingly compact, and in this case, less expensive parts.

Only the tube, fuse, and transformer, as indicated in Fig. 2, are required in the charger circuit. As no energy worth mentioning is wasted in the tube, it may be made quite small itself, and as the transformer does not have to supply a great deal of useless energy, its core need not be any larger than those of some of the new high-quality audio transformers.

RATE OF CHARGE

THE new "A" tube lends itself to either full-wave or half-wave rectification. When used as a half-wave rectifier, the maximum charging rate consistent with long life is $2\frac{1}{2}$ amperes. By means of suitable ballast resistors of $\frac{1}{2}$ ohm each, several "A" tubes may be operated in parallel for higher currents. In full-wave rectification, the charging rate may be double that for one "A" tube. While the tube

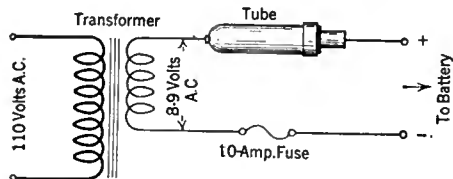

FIG. 2

will have a longer life when used as a trickle charger than when used as a comparatively high-rate charger, its use as a trickle charger is not recommended, due to the necessity for a tremendously long life for rectifiers suitable for such use.

But is trickle-charging so desirable after all? As an answer to the demand made by the public for an A power unit and the elimination of the A battery and charger, many manufacturers brought out trickle chargers and circulated much information regarding the advantages of such a method of charging.

Both systems have their merits. The outstanding advantage of trickle charging is convenience.

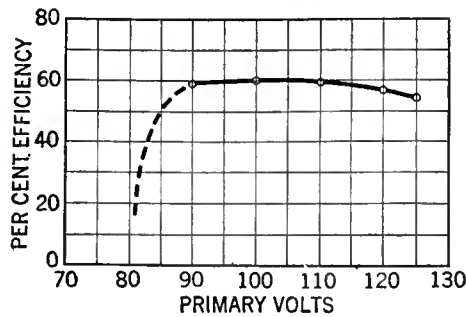
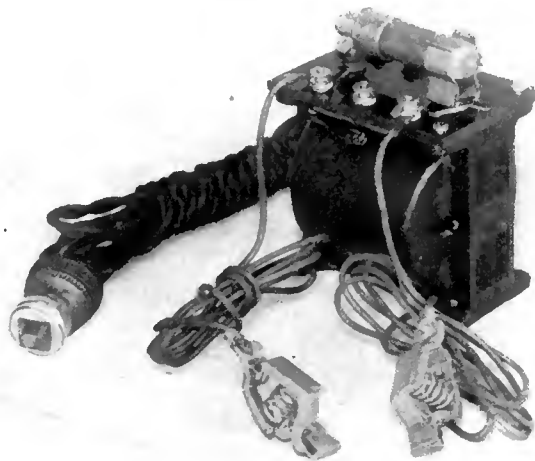

FIG. 1

There is no need to remember to turn on the charger for an overnight run each week, and if the charging rate is properly adjusted,



ANOTHER COMMERCIAL UNIT

This one is manufactured by the Mayolian Company, of New York. It is a half-wave charger

there is never the inconvenience of a run-down battery.

But against the advantage of convenience must be placed lower electrical efficiency (which means greater operating costs), the difficulty of determining and then obtaining the optimum charging rate, and, finally, shorter battery life.

The storage battery manufacturers tell us that, as far as the life of the battery itself is concerned, the ideal charging system would consist of a high-rate initial charge, to remove any sulphate formation on the plates, and greatly reduce the time required for the complete charge, followed by a gradually decreasing rate of charge in order to prevent excessive gassing and thus slow disintegration of the positive plates as the charge nears completion.

In good battery service stations, charging

batteries at a high rate which gradually tapers off is accomplished by manually regulating the charging rate, as the state of the battery changes, by means of field rheostats on the motor-generators employed for charging.

In some types of chargers, where the secondary voltage is from 20 to 30 volts, the rise in back-voltage as the battery reaches its fully charged condition is only a small percentage of the total impressed or secondary voltage. Since the current flow is governed by the difference between the impressed voltage and the back voltage of the battery on charge, no great change in current flow will take place and there is not the advantage to be gained of a tapered charge.

Because of the high efficiency of the charger discussed here which permits of low secondary voltage, the variation in battery back voltage, as it approaches its fully charged condition, is a large percentage of the total effective voltage of the circuit, thus resulting in a very decided decrease in current flow, and thereby automatically producing a condition of tapered charge which is so beneficial in battery charging.

The curves given in Fig. 3 show this phenomenon clearly at various charging rates.

Fig. 4 shows the wave form of the output of the Raytheon "A" tube as indicated by an oscillograph. An oscillograph gives a visual indication of the variation of voltage or current, as the case may be, in an electrical circuit over a period of time. Thus, from Fig. 4, it will be seen that the current increases in a positive direction with time until a maximum is reached and then falls off to zero. Instead of then continuing to build up in a negative direction, as in the case of an alternating current, Fig. 5, the rectifier tube effectively opens the electrical circuit and the current remains zero until such time as the alternating line voltage has passed through another half cycle ($\frac{1}{2T}$ of a second in the case of a 60-cycle supply) at which time the rectifier tube closes the circuit and permits the current to build

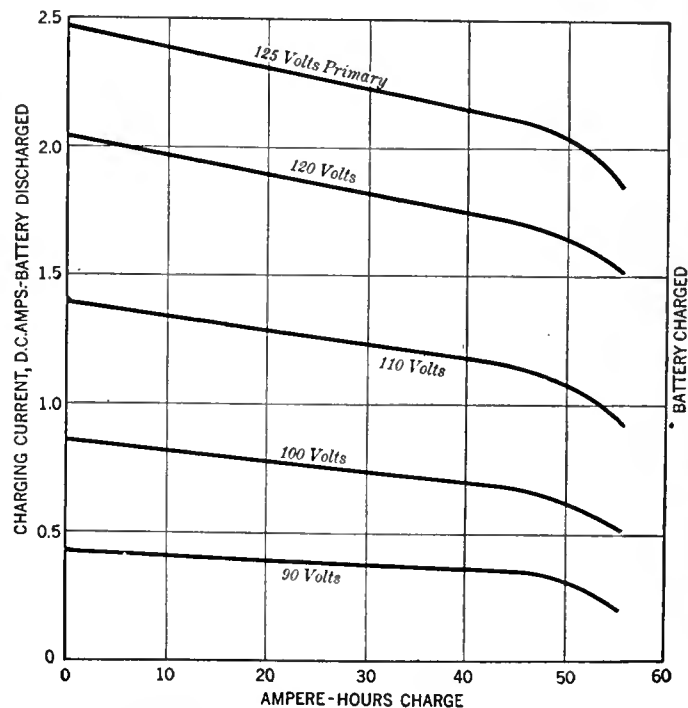

FIG. 3

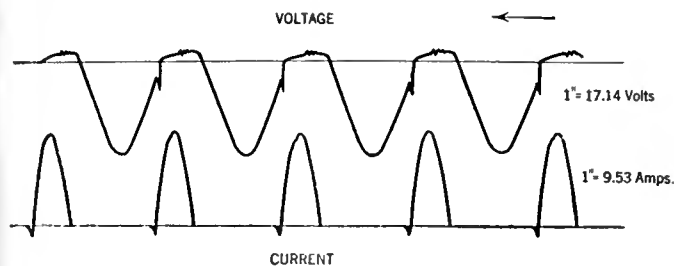

FIG. 4

up again in the same direction as the first half cycle.

One of the purposes of making oscillograms of the operation of the rectifier tube is to ascertain just how completely it prevents current flow in the wrong direction during the half cycle when it should prevent current flow. A perfect rectifier would let no current through in a negative direction.

"A" TUBE CHARGER DESIGN

A NUMBER of prominent manufacturers, such as National, Thordarson, and Mayolian offer for sale complete chargers using this new tube. For those who wish to construct a charger at home using the new rectifier tube, details for the transformer are given in Fig. 7, and a photograph of the equipment appears on this page.

Consider the circuit diagram for the single-wave unit shown in Fig. 2.

Any well made transformer of about 20 watts capacity and with a low-resistance secondary having an open circuit voltage of between 8 and 9 volts may be used. It is preferable to mount the rectifier tube with the small end up. The fuse clips should be used, one making contact with the body of the tube and the other with the small cylinder projecting from the top.

The small cylinder (cathode) should be connected to the positive output circuit while the body of the rectifier (anode) should be connected through the transformer to the negative.

A fuse of not over 10 amperes capacity must be connected in the charging circuit to prevent damage should the output of the charger become short-circuited or the battery be connected in the reverse manner. Small automobile cartridge fuses are excellent for this purpose.

Perhaps it may occur to some readers that a charger with variable rate may be readily constructed from a transformer with a higher secondary voltage than that described, by inserting a rheostat in series with the tube. Such is not the case. The maximum back voltage that the tube will withstand without injury is 22 volts. As there is no current flowing during the half cycle in which the battery is not charging, IR drops become zero and the back voltage becomes equal to the peak a. c. secondary voltage plus the battery voltage. Thus, for long tube life, transformer voltages must be limited to 8

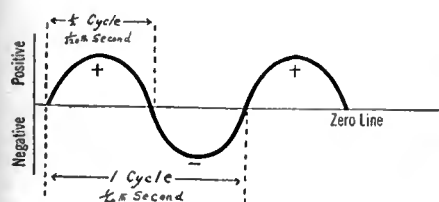

FIG. 5

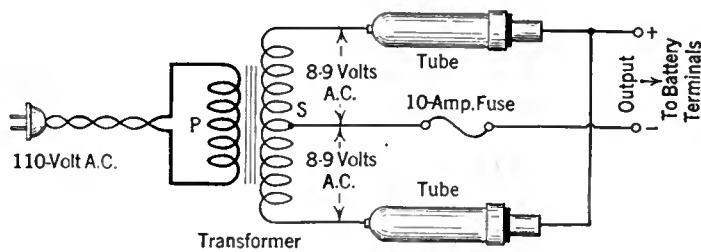

FIG. 6

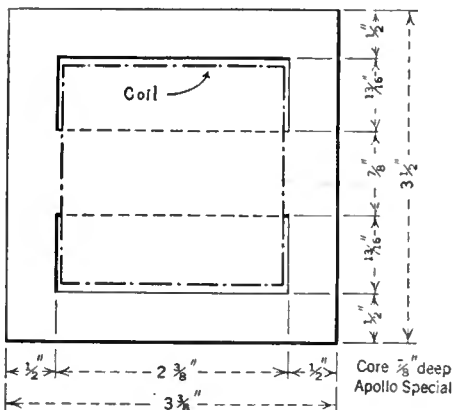

FIG. 7

Here are the specifications for the construction of a transformer suitable for use in a home-made charger using the new "A" tube. The transformer should be of the customary shell type with a core having dimensions equivalent to those given here. The primary of the transformer consists of 750 turns of No. 24 enameled copper wire, while the secondary consists of 53 turns of No. 14 single cotton-covered enameled copper wire. The transformer coil should be layer wound with the secondary coil next to the core. The usual insulation between layers, between core and secondary, and between primary and secondary, should of course also be provided

or 9 volts at no load. (Peak A. C. voltage = $RMS \times \sqrt{2}$).

The National charger shown in the photograph on page 143 and diagrammatically in Fig. 6 is so designed as to be used either as a half- or full-wave charger. As a half-wave charger, only one rectifier tube is plugged in, while as a full-wave outfit both tubes are employed. The charging rate with one tube is approximately 2 1/2 amperes and with both tubes 5 amperes. The manufacturer's price is \$10.00 without tubes; the tubes are \$4.50 each.

The Mayolian Charger, which is shown in a photograph on page 144 lists for \$10.00, and the Thordarson charger lists for \$12.50 complete.

The new rectifier unit is already being applied to A elimination and at least two manufacturers have complete A-units ready for the market at present.

There are many tricks to the successful design of such devices however, and the development of suitable filter circuits has been exceedingly difficult. The present commercial units employ several chokes with quite low inductance and exceedingly low d.c. resistance. Instead of ordinary condensers, special dry cells, offering a very high d.c., and at the same time extremely low a.c. path are employed.

Some of these units or cells are based on the principle of the electrolytic condenser, but use a paste electrolyte rather than a liquid.

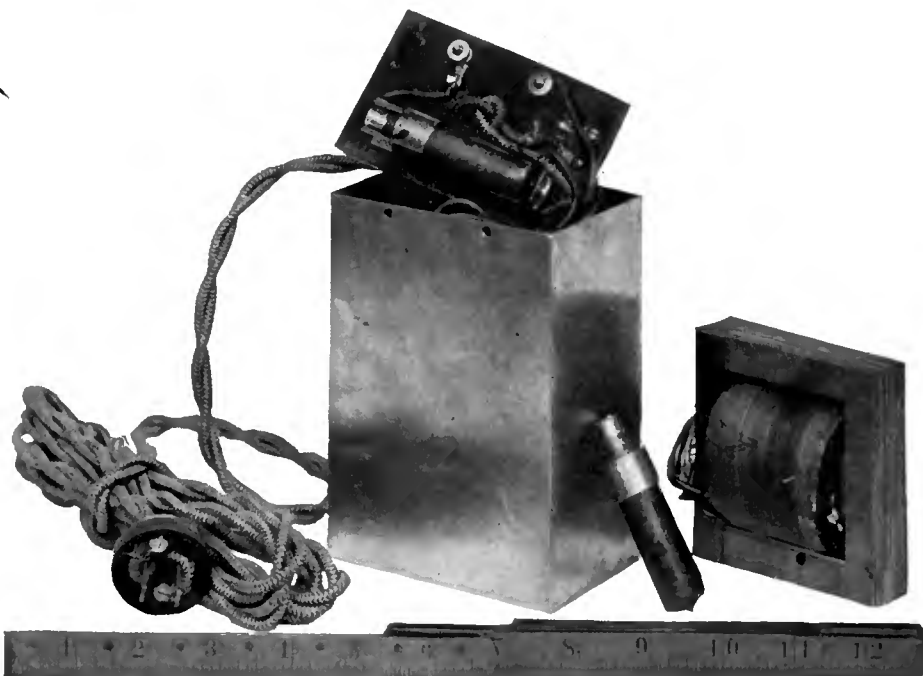

THE HOME-MADE UNIT

Fig. 6 is the schematic diagram that should be followed in building this full-wave 5-amp. charger



"Strays" from the Laboratory

Measuring Audio Amplifiers

AS HAS already been mentioned in these pages, progress of standardization in the radio industry is encouragingly sponsored and aided by two organizations—the Radio Manufacturers Association and the radio section of the National Electrical Manufacturers Association. Considerable effort has been made by both organizations to standardize not only mechanical and electrical constants of radio apparatus but methods of measurement as well.

In the booklet giving the NEMA radio standards there can be found a method of testing audio-frequency coupling devices—transformers, resistance-condenser, and choke-condenser couplers. The problem of output devices has not, as yet, been included. The method of measuring transformers is not new, nor, in the opinion of many engineers, is it correct, in that it does not give a true picture of what the transformer will do under actual working conditions.

The circuit diagram of the test equipment is shown in Fig. 1. Briefly it consists of an oscillator whose frequency range is 30 to 7000 cycles and whose "percentage of harmonics present in the output shall be not more than 5 per cent." Current from this oscillator is passed through a potential divider and is read on a thermo-couple-milliammeter. A portion of the output voltage is impressed on the primary of the coupling device under test in series with a fixed resistance to simulate the plate impedance of the tube out of which, in normal practice, the coupling unit works. Arrangements are made for direct current to flow through the primary.

A given deflection on a vacuum-tube voltmeter is obtained by placing its terminals across the secondary or output side of the coupling device. Then the same deflection is obtained by impressing the oscillator output voltage directly on the tube voltmeter by means of a slider on the potential divider. Since the resistance through which the coupling device is fed is fixed, the ratio of these resistances gives the voltage gain of the coupling device.

Criticism leveled at this method arises from the fact that the input characteristics of the vacuum-tube voltmeter differ from those of a tube with an inductive load in the plate circuit—such as would normally work out of the coupling device. The frequency characteristic of the

transformer depends upon what is shunted across its secondary or output terminals. In the Laboratory, and elsewhere, it has been found that the curve obtained in this way may have very little in common with that obtained from a complete amplifier, or even from a single coupling unit plus one amplifier tube.

The question naturally arises as to what is the best method of measuring a coupling device or an amplifier. Shall the curve obtained by the NEMA method be taken as standard; shall the overall characteristic of two or more coupling devices with their associated tubes be preferred; and if so, how shall the output be measured? That is, with what is the amplifier to be terminated; if a resistance, of what value? Are we interested in the amplifier as a power amplifying device; shall the output power be measured, or is it sufficient to measure the voltage appearing across, say, the primary of an output transformer and to divide it by the input voltage to

Sons are compelled to pass the hat to keep this magazine going, they will receive strong support from American engineers, for this paper is without a peer as an organ for serious engineers and experimenters. In England a research is undertaken, it seems, with the love of pure science in the investigator's heart and not with one hand tied by production department threats. The English may pursue roundabout methods, but the end point is final and the answer is complete. No American deeply interested in radio science can afford to be without *Experimental Wireless*, even were the price raised to five or six "bob" per month.

Batteryless Receivers

THE Laboratory has witnessed the demonstration of two radically different systems of battery elimination in receivers within a month, one employing the high-voltage high-current rectifier tubes, the uses of which are outlined elsewhere in this issue of RADIO BROADCAST, and the other a method made possible by the so-called Miessner tube.

The Raytheon, QRS, and similar rectifier tubes, are designed to rectify enough current so that 201-A tubes can be wired in series and 250 milliamperes passed through them. The rectifier system must furnish five volts for each tube filament and also the high plate and grid bias voltages of the power output tube whose filament is heated from raw a. c. A five-tube set using four 201-A's and a 171 will require 20 volts for the filaments, 40 volts C grid bias, and 180 volts for the 171 plate; since the filament voltage is also available for the plate voltage of the last tube, the total will be 220 volts.

The Miessner tube is the high-current low-voltage valve predicted in the February and March RADIO BROADCAST and mentioned again in May of this year. The thermal inertia of the tube is so high, about sixteen times that of 112, and the voltage drop across the tube so low, that it is possible to place raw a. c. on the filament without introducing appreciable a. c. hum into the output. In fact, the ripple in the output, produced by incomplete filtering, can be made to serve a useful purpose. Since the plate current produces a ripple in the C bias which, is opposite in phase with that in the plate circuit, the a. c. hum which would otherwise emanate from the loud speaker is automatically reduced.

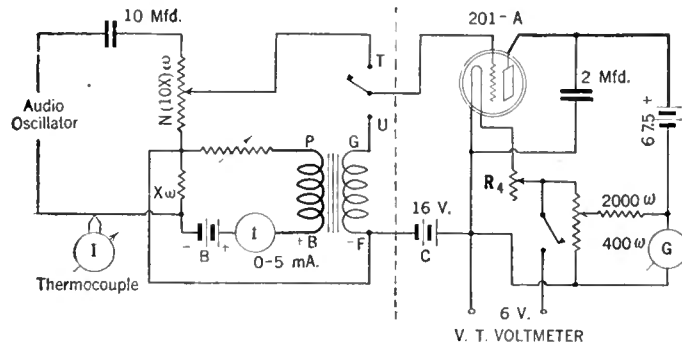

FIG. 1

the amplifier to obtain the overall voltage gain?

These questions have occurred in letters from laboratory experimenters who would use standard test methods if such could be agreed upon. It is possible that they have occurred to members of the standardization committee of the RMA and the NEMA too, and it is probable that readers who have suggestions will find willing ears.

A Fine British Magazine

IT IS disappointing to note that one of the best British technical journals, *Experimental Wireless and the Wireless Engineer*, published in London by Hliffe and Sons, has been compelled to raise its subscription price to two shillings and sixpence per copy on account of "lack of support by English advertisers." Without a doubt if Hliffe and

And now that it is possible to throw away one's batteries, is it worth while? What are the advantages either way?

For the Raytheon and QRS outfits it must be conceded that the power problem indeed seems simplified. There are no acids or liquids, and it is possible to supply the high plate voltage of the final audio tube economically and continuously. There are no chargers constantly and sometimes inefficiently dissipating power; no batteries to fill with water, and few replacements.

On the side of the battery the advantages are also manifold. Battery voltages are pure unadulterated d. c. This means that a high-quality battery-operated amplifier and loud speaker will be quiet until a signal comes in and it will be possible to use headphones after a two-stage amplifier; this is frequently impossible with distance reception on account of the a. c. hum

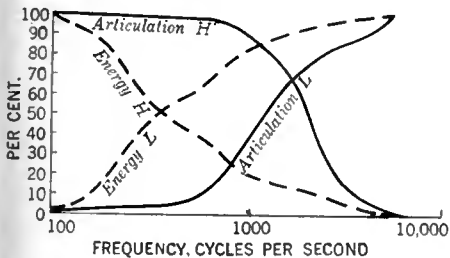

FIG. 3

which is more annoying in headphones than in a loud speaker. There is no a. c. hum whatsoever in the case of battery-operated sets, and there are no voltages higher than that necessary for the last tube. B batteries have a practically perfect regulation curve, i. e., they are of very low resistance when new. There is no heat to be dissipated. Either a. c. or d. c. may be used to charge the A battery, and the charging process may be made almost automatic.

The honors seem about even. Now let us look at the economics of the problem. Suppose the first cost of a battery and a charger is \$30 while it costs \$60 to equip one's set with a QRS or Raytheon A, B, C, supply. Further, suppose it costs \$30 a year to run the power operated receiver and that batteries cost, for a year, about \$50. This latter figure includes B batteries and charging the A battery.

At the end of the first year the power set has cost \$90 compared to \$80 for the battery receiver. At the end of the second year the respective total costs are \$120 against \$130. Thus, from the standpoint of economics, at the end of two years, there is little gained or lost by one method or the other. Figures on the Miessner system are not yet available.

Articulation Curves
THERE are few independent laboratories that have the equipment to measure the effectiveness of a receiver from input radio-frequency voltage to output sound pressure from the loud speaker. For this reason, some data presented at a meeting of the Radio Manufacturers Association, held in New York on March 23, 1927, by Dr. John P. Minton and his associate, I. G. Maloff, are more than interesting.

Fig. 2 shows the frequency response of three loud speakers, curve A being a representative horn speaker, curve B an average cone speaker, and curve C "one of the best cone speakers

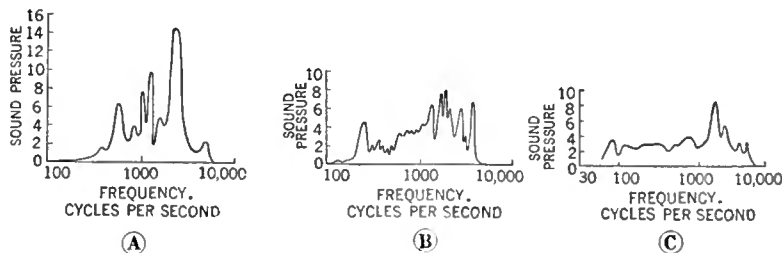

FIG. 2

that has been produced." It may be seen that the horn has an effective range of from 450 to about 3000 cycles, the average commercial cone covers from 200 to about 3600 with several severe "ups and downs," while the third curve is good from about 60 to 6000 cycles.

These curves of Dr. Minton's by themselves are nothing more than interesting, but when looked at with other data collected by such authorities as Dr. Harvey Fletcher and Dr. Minton himself, they become illuminating. For example, the curves shown in Fig. 3 give an idea of what happens when frequencies above any desired frequency are not reproduced, "L", and conversely "H" shows when only the high frequencies are passed through the receiver and loud speaker. From the standpoint of intelligibility or articulation the low frequencies are not so important, but if no frequencies below 500 cycles are reproduced, there will be but 40 per cent. of the speech energy present in the loud speaker output. On the other hand, the high frequencies carry little energy but are important from the standpoint of intelligibility. If all over 1000 cycles are cut off, 80 per cent. of the energy remains but only 40 per cent. of the articulation or intelligibility. From this consideration and others it seems certain that frequencies between about 75 and 5000 should be reproduced equally for faithful reproduction of music.

Fig. 4 gives the comparison of sound pressures at various frequencies occurring in organ music, which explains why a poor loud speaker or poor amplifier makes organ music sound like anything but organ music.

Fig. 5 gives the overall radio amplification against wavelength of several common types of receivers. Curve S is for a super-heterodyne;

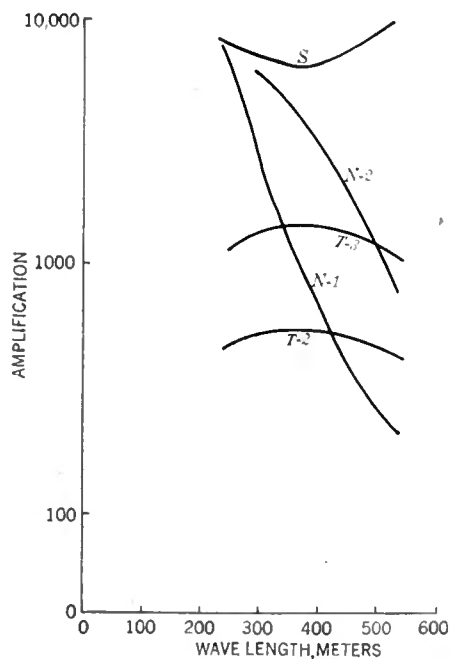

FIG. 5

curve N-2 is for a dual-control neutralized receiver of commercial make, while curve N-1 represents a single-control receiver of the same type; T-2 and T-3 are representative two- and three-stage resistance neutralized receivers.

Mr. Maloff makes several interesting and significant statements, of which the following are of special interest:

"For some unknown reason the importance of adequate audio amplifiers was overlooked by many manufacturers. Many sets on the market have very good r. f. circuits but very few of them have audio circuits of the same grade."

"In a certain commercial set the transformer form of coupling is used, the transformers being of high ratio and insufficient primary impedance. This set is very quiet even with the worst kind of battery eliminator, but responds only to the frequencies in the middle range, which means

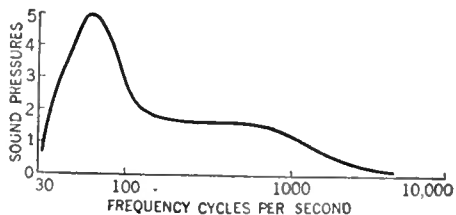

FIG. 4

lack of depth and lack of brilliancy of the reproduced sound."

New Equipment

TWO instruments that deserve more than ordinary attention have recently been received by the Laboratory. One of these is the Taylor resonance tester, which consists of a small radio-frequency oscillator and a vacuum-tube voltmeter, all in one cabinet. It is for use in "lining up" two or more radio-frequency stages that are to be controlled by one dial. The second instrument is the Weston set tester, comprising a milliammeter with several shunt and series resistances and a multiple switch so that the meter can be used to measure plate current, and filament, grid, and plate voltages, as well as to test for opens, etc. Further interesting equipment received is as follows:

The Elkon dry rectifier, recently described by R. S. Kruse in *QST*; the Sprague tone control, for use between the amplifier and loud speaker; grid leaks and resistors made from Carborundum; electron relay tubes which will open or close a circuit through the influence of a distant signal; the Crosley AC-7 receiver, which operates without batteries; another automatic radio power relay, known as the Liberty 712S; a grand assortment of Fahnestock clips; tapped heavy-duty resistors from Mountford; a little vest pocket receiver by Flash, that actually receives signals from Manhattan, twenty miles away; experimental four-element tubes from Clearton and Van Horne; condensers for various uses from National and Wireless Specialty; output devices by Centralab, Muter, and Silver-Marshall; the new high-quality General Radio audio transformer, type 285 N; Carter's radio kit No. 400, comprising the necessary resistors for use in an A, B, C, device employing the new QRS 400-mil. tube; resistors from Cresradio; the Davy Vertrex Autocharger; new Paragon double-impedance units; Browning-Drake and Loftin-White receiver kits.

Complete Constructional Data for Converting a Popular 19-Inch Cone Loud Speaker Into a Three-Foot One—Cone Kits Available

**By
WARREN
T. MITHOFF**



A THREE-FOOT CONE
It is a fairly simple matter for the fan interested to make himself a three-foot cone, and obtain superior reproduction of music. The one illustrated to the left is described by the author and makes use of a Western Electric 540-AW unit

How to Build a 36-inch Cone

THE true dyed-in-the-wool radio fan is never content with his equipment, however excellent it may be. The constant urge is for improvement, advancement, and change. Hence, manufacturers are able to market with considerable success such items as super-sensitive detector tubes, \$10 transformers, and improved loud speakers.

Thanks, in large measure, to the inquisitiveness of the aforementioned fan, radio has advanced more rapidly than most other sciences of a similarly complex nature. Take loud speakers, for instance. The moderate-sized cone of to-day is vastly superior to the tinny-sounding horn of five years ago; yet there looms on the horizon a much enlarged edition of the cone, costing nearly three times as much, and giving noticeably better quality. In theory, and in practice as well, perfect reproduction requires a large diaphragm—within reasonable limits, the larger the better. Therefore, the three-foot cone sets itself up as a contender for highest honors in the struggle for better radio music.

Many fans have doubtless wished for one of these giant cones, but for various reasons have foregone the pleasure and pride of possession. For the owner of a Western Electric 540-AW loud speaker, however, there is a short cut to ownership without having to pay the penalty of excessive transportation and handling charges which attaches to the manufactured three-foot cone. He can build the cone himself, and install in it the excellent 540-AW driving unit, or any one of a number of other good units now obtainable, thereby gaining every advantage of the large cone at a minimum of expense. Where the 540-AW unit is removed from the cone for this purpose it does not necessarily follow that the smaller cone is permanently useless. The actuating unit is retained intact,

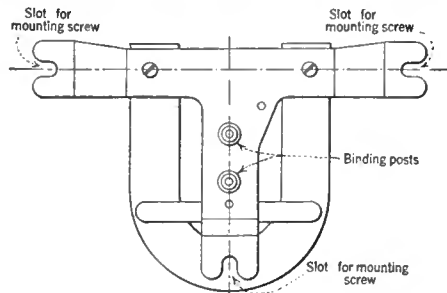

FIG. 1

so that on occasion it can be put back in the smaller cone should a more portable loud speaker be desired.

MOUNTING THE UNIT

IT IS the purpose of this article to describe the process necessary in building a giant cone and the 540-AW unit will be employed for the purpose

although practically the same procedure will have to be followed where other units are used. First, we must gain access to this 540-AW unit. The five screws holding the perforated bronze screen are removed, and the screen taken out. The rear of the unit proper is then disclosed; in appearance, it is somewhat like Fig. 1. Now, the set screw at the tip of the cone is loosened, and the three mounting screws holding the unit to the circular frame are removed. The unit is then drawn out, care being exercised to see that the driving pin is not bent. For the large cone it is desirable first to mount the unit on a flat surface. A piece of hard wood, such as oak or maple, serves admirably, and it is easily worked. This should be at least $\frac{3}{4}$ inch thick, and should be a heavy close-grained wood. Weight is needed back of the unit to preclude the possibility of the unit vibrating instead of the paper cone.

This mounting base is planed smooth, cut to size, and drilled as indicated in Fig. 2. The $\frac{1}{2}$ -inch holes near the center are simply to clear the binding posts on the unit, which project somewhat beyond the plane of the three slotted mounting feet.

The next step is the preparation of the supporting arm, Fig. 3. This may be of soft wood, and should, at the start, be made about $4\frac{1}{2}$ inches long. The exact distance from tip to back of the three-foot cone may vary a little in individual cases, and it is easier to cut off than to add on.

The mounting base is now fastened to the supporting arm by means of three flat-head wood screws, fairly heavy, and about $1\frac{1}{2}$ inches long. The arm is placed at the top of the base, in the exact center, and the three screws are passed through the countersunk holes and tightened.

Fig. 4 shows the details of the cross piece which supports the entire assembly inside the cone. It may be made of soft wood, drilled as indicated,

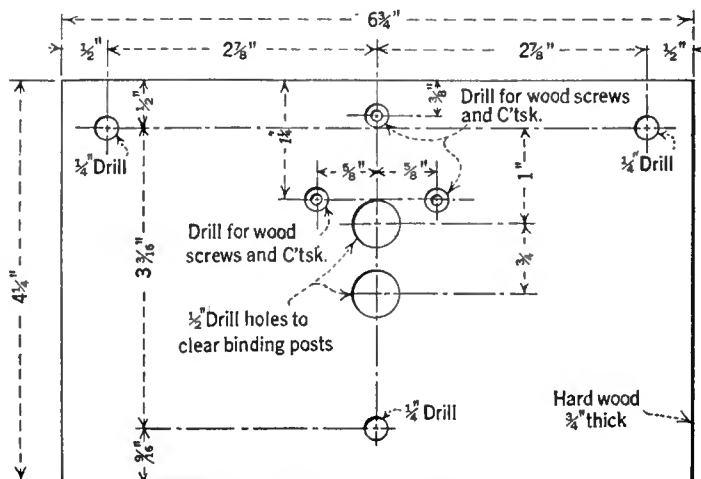

FIG. 2

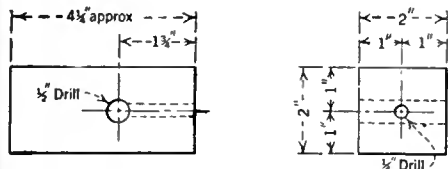

FIG. 3

and stained with walnut wood stain. A No. 14-20 machine screw, 3 inches long, is now obtained, and washers slipped over it in this order: Next to the head a lock washer, then a 3/4" washer with a 1/2" hole, then a 1" washer with a larger hole. The screw is passed through the 1/2" hole in the cross piece, through the 3/4" hole in the supporting arm, and the nut, either hex or square, is placed in the 3/4" hole, so as to thread onto the screw, which is then tightened up. The reason for the apparently oversized 3/4-inch hole in the cross piece will be evident later on in the construction.

The unit is mounted on the baseboard by means of round-head machine screws 1 inch long. These may be of any size that will fit through the slots in the feet of the unit, and are passed through the slots, and through the 1/2-inch holes in the base and drawn up tight. Lock washers are

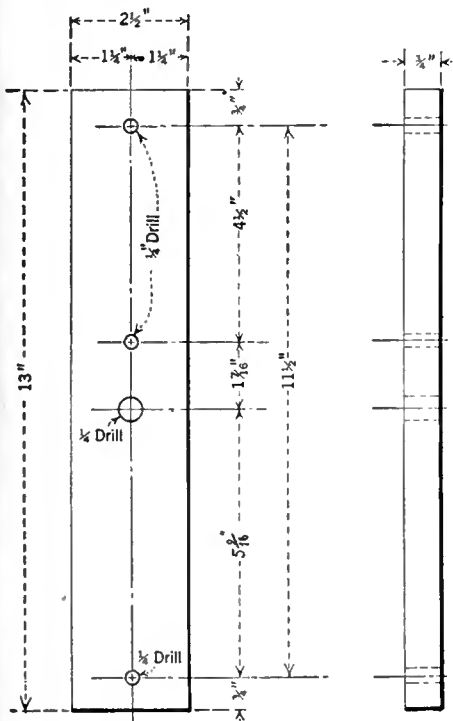

FIG. 4

advisable at this point, also, together with flat washers against the surface of the wood.

THE DIAPHRAGM

THE mechanism may be laid aside now while the cone itself is made. The first consideration is the choice of a paper for the purpose. Brown Alhambra Fonotex is probably best for quality of tone, ease of working, and appearance. It can be had in sheets 38 inches square at many radio stores, or from the manufacturers' agents. Another possibility is lamp shade parchment, which comes 40 inches wide. While this is not theoretically so good, being more compact and harder-surfaced, in actual practice it works very well, although it is a little more difficult to handle in the making. A thin coat of walnut wood stain gives it a rich brown color.

A few pointers regarding decoration may not

be amiss at this point. If the Alhambra paper is used, it is a simple matter to decorate the face of the cone with water colors, and a very pleasing effect can be obtained by the use of simple bands of dark brown around the outer edge, as shown in the photograph. The procedure is as follows: A 38-inch sheet of the paper is laid, rough side up, on the floor or on a flat table and the exact center determined by means of crossed diagonals. A thumb tack is driven in at the center, and a piece of wire is used as a compass for drawing the circles. The largest circle should just fit on the sheet, and will have a diameter of 38 inches, or nearly that. The wire is then shortened in steps, and four more circles drawn to locate the bands. The outer margin is 1/8 inch; then a 2-inch band; then a 1/2-inch space; and then a 3/8-inch band. If the constructor has access to a draftsman's ruling pen, the decorating is simplified. A good water color to use is burnt umber, or Van Dyke brown, in tube form. A little is squeezed out in a dish and thinned with water. It may then be taken up on a brush (a No. 5 flat lettering brush is excellent) and applied to the ruling pen, which is used with the wire compass arm, and a circle drawn over each of the pencil lines. This makes it much easier to get a smooth edge on the bands when filling in with the brush.

The actual construction of the cone is accomplished by cutting out a 5-inch segment as shown in Fig. 5, with the grain of the paper. The direction of the grain is indicated on the wrapper. The circular form is then cut out and the sheet turned over, face down, and the two edges of the segment drawn close together and weighted down. A strip of paper about 1 1/2 inches wide is cemented over the two edges, and a ruler laid over it and heavily weighted while the glue dries. A very good adhesive to use is Ambroid cement, a celluloid base mixture which is waterproof and will not buckle the paper.

While the face of the cone is drying, the back can be made, noting that the segment is to be 5 1/2 inches at the outer edge, as shown in Fig. 5. This cone is cemented the same as the first one, with a strip of paper, and weighted down to dry.

MOUNTING THE CONE

NEXT, the wood ring, Fig 6, is cut, drilled, sanded, and stained with the walnut stain. When dry, the ring is laid flat on the table and the back cone is mounted on it so that the inner circle centers, and the seam in the paper is opposite one of the projections on the ring. Care must be exercised to see that the cone is not pulled out of shape while fastening it in place. It is best to drive six tacks, evenly spaced, through the edge of the paper to hold it temporarily and then check up the placing of the cone by putting the front cone in position and noting whether or not the edges meet evenly all around. If not, the tacks should be pulled out and the paper shaped so that it will. After the back cone has been adjusted properly, and tacked down, it is firmly secured by a coating of sealing wax applied quite liberally while very hot. The wax should cover the entire circumference thoroughly, and be allowed to harden.

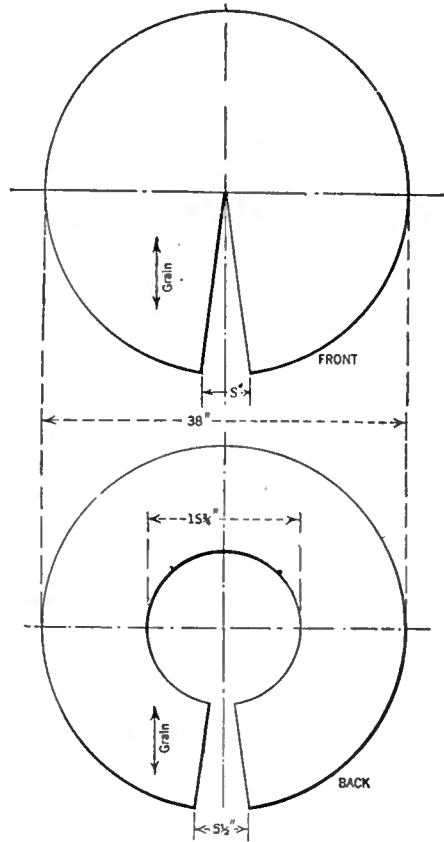

FIG. 5

The front cone is now placed, point down, in a round dish pan, which serves as a support, and the back cone fitted onto it, edge to edge, with the seams meeting. The two are joined together with the Ambroid cement, or with sealing wax. The front cone, having a smaller segment removed, will be a trifle larger than the other, and the cement or wax is applied along this slight extension. The cement or wax is applied freely, but not allowed to run over onto the face of the cone.

The next step is the making of the tip, Fig. 7.

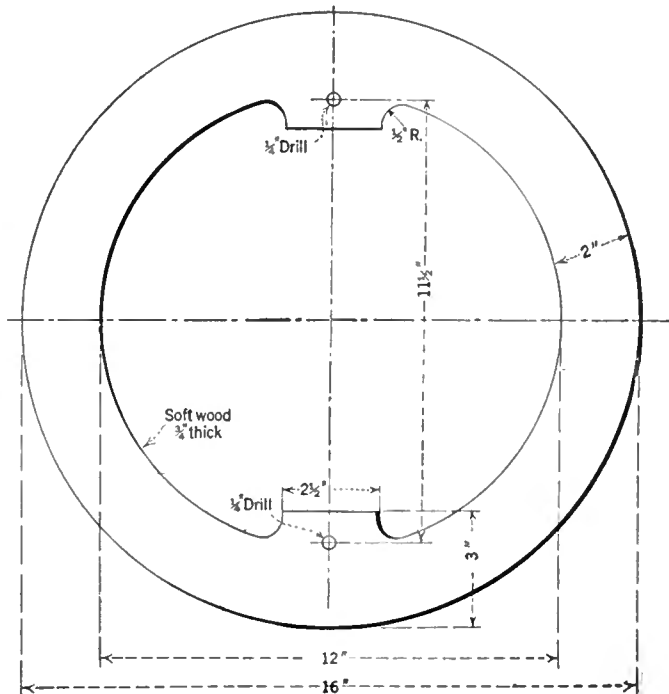

FIG. 6

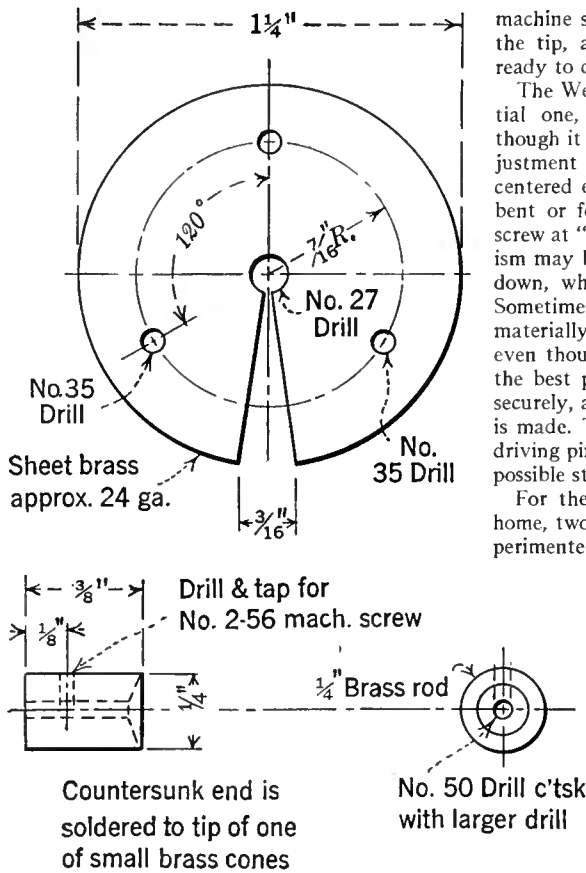

FIG. 7

The two circles are cut from thin sheet brass, drilled, and segments cut out. These should then be shaped into cones and the seams soldered lightly. The tip is cut from 1/4-inch round brass rod, drilled, and tapped as shown. This tip is then soldered carefully onto the apex of one of the brass cones, and excess solder removed with a file.

The two brass cones are given a light coat of the Ambroid cement, and secured to the point of the paper cone by three No. 2-56 machine screws passed through the holes drilled for them. (See assembly, Fig. 8). The nuts are tightened on the inside, and the cone is ready to receive the actuating mechanism.

At this point the constructor will find it convenient to make a temporary stand to support the cone while work progresses. This may consist simply of a 12-inch board about 3 feet long, laid flat on the floor, with uprights nailed to the edges and braced. The uprights are fastened to the wood ring on the back of the cone with wood screws, and thus both hands are left free for adjusting the unit. Or, if the experimenter's workshop is in the basement, he may nail two narrow strips to an overhead beam and hang the cone in that fashion.

ASSEMBLING THE LOUD SPEAKER

THE cross piece, supporting the driving unit, is now put in place, the driving pin being pushed carefully through the metal tip. Should the driving pin extend too far, or should the supporting arm be too long to permit the cross piece to rest against the wood ring, the arm must be removed and cut down accordingly. No. 14-20 machine screws are inserted in the holes in the cross piece and wood ring, with flat washers and lock washers on the inside, and flat washers on the outside. The nuts are tightened on the inside, and the loud speaker cord brought out through the 1/4-inch hole in the cross piece. A No. 2-56

machine screw is inserted in the tapped hole in the tip, and tightened, and the instrument is ready to connect for a test.

The Western Electric unit is a very substantial one, and trouble is extremely unlikely, though it may be necessary to make a slight adjustment to make sure that the driving pin is centered exactly at the tip of the cone and not bent or forced out of place. By loosening the screw at "A," Fig. 8, slightly, the entire mechanism may be shifted from side to side, or up and down, while the loud speaker is in operation. Sometimes the quality of tone can be improved materially by this process, and it should be tried, even though it may not seem necessary. When the best point is found, the screw is tightened securely, and a final adjustment of the set screw is made. The screw on the tip which holds the driving pin to the cone is loosened to relieve any possible strain and then tightened again.

For the final disposition of the cone in the home, two methods suggest themselves. The experimenter who is handy with carpenter's tools may wish to build a three-legged stand similar to the one shown in the photograph on page 148. A simpler method is to hang the loud speaker on the wall. Two small rubber-tipped cast-iron door stops are procured, such as are used to prevent doors from banging into the wall. These are screwed into the lower part of the wood ring to hold it away from the wall, and a screw eye at the top will accommodate a cord. The cone may then be hung from a hook on the picture molding.

For the benefit of the experimenter who does not possess a Western Electric 540-AW loud speaker, there are on the market several excellent units which can be handled in a manner similar to that described here. Dimensions, of course, will differ, but the general procedure is the same. The fan can readily adapt the individual unit to the plan given here, and provided the unit chosen is a good one, excellent results may be obtained at a very nominal cost.

NOTE

MR. MITHOFF'S instructions fully cover the construction of a 3-foot cone loud speaker where the Western Electric 540-AW cone loud speaker is taken apart to supply the driving unit. There are, however, as Mr. Mithoff explains, several other units which may be obtained separately and installed to good advantage in the 3-foot cone.

Several companies have for sale complete kits for the home assembly of such cones, comprising the driving unit, mountings, and cone paper. The following is a brief description of these kits:

Fenco Cone Speaker—This kit comprises two pieces of cone paper, a driving unit, wooden back ring, handle, cord, glue, and cement. The two sheets of paper are cut in circular form, both are marked for the cutting of the segment to form the seam, and one is decorated with a border

stencil. Supplied by Fenco Cone Company. Price \$12.00.

Enso Cone Speaker—The parts supplied include one sheet of cone paper, uncut, one central mount block with four arms, one driving unit, and one loud speaker cord. Supplied by the Engineer's Service Company at a price of \$10.00.

Penn Cone Speaker—Consisting of one driving unit, two sheets of cone paper, uncut, one set of back rings, one unit mounting, and one can of cement. Supplied by the Penn Radio Sales Company, for \$14.15.

Instruction booklets explaining the construction of each of the cones listed above are supplied by the manufacturers and deal specifically with the assembly details involved.

Balsa Wood Reproducer—While this loud speaker kit is not of the cone type it is of sufficient size to be classed in that category. Instead of being circular or conical in shape it is rectangular and much like a picture frame. It is obtainable in three sizes: 24"x 13", 36"x 21", and 43"x 24".

The kit consists of frame material, three wide slats of special balsa wood, a number of pieces of narrow ribs of balsa wood, glue, brads, screws, chuck, and wood mounting for chuck.

The three slats are assembled inside the rectangular frame and the ribs are glued to the back of the slats in a radial fashion. At the center, where the ribs join, the chuck and mounting is placed to take any good loud speaker driving unit. Furnished by the Balsa Wood Reproducer Corporation, price \$5.50, \$8.00, or \$10, depending upon size.

—THE EDITOR.

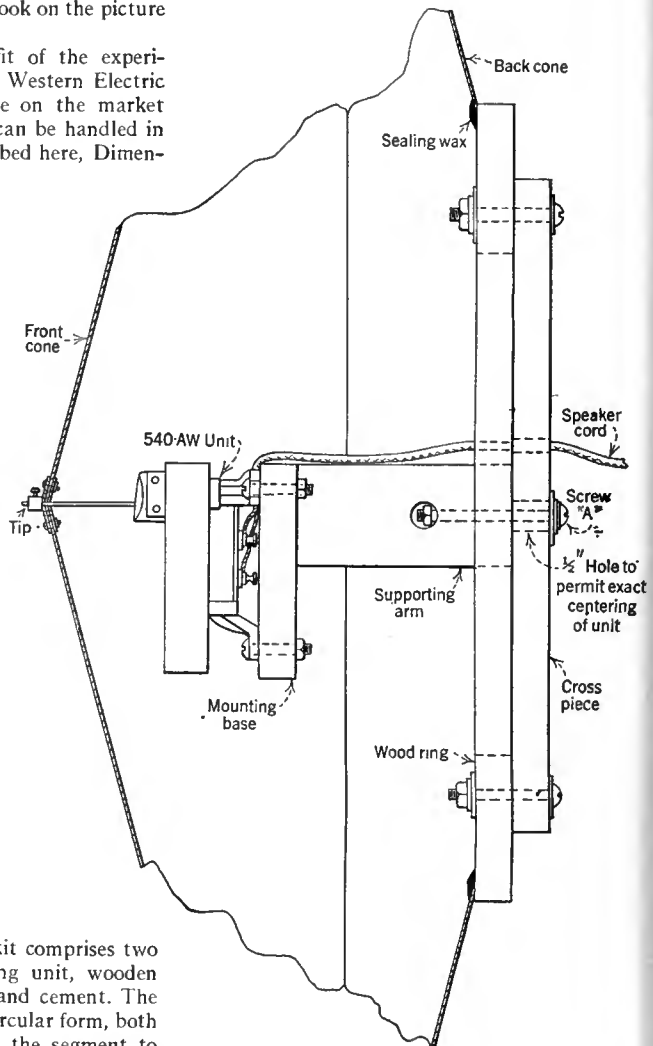

FIG. 8

Something About Single Control

Some of the Advantages and Disadvantages of Unified Control—Analyzing the Single-Control Receiver—Why Synchronism of Circuits Is Complicated

By EDGAR H. FELIX

SIMPLIFIED tuning is only one of the important advantages gained by the simultaneous adjustment of circuits by means of a single control. It is a most important advantage to the inexperienced, but even the most skilled dial twirler soon finds desirable qualities in a real one-control receiver.

For example, the attainment of true single control makes it possible to sample all the available programs throughout the frequency range in a brief time, thereby increasing the entertainment value of the receiver. Furthermore, appearance, in the opinion of many, is improved by the reduced number of controls.

One conspicuous knob plus several small ones, however, does not necessarily make a true single-control set. There are many pseudo-single-control sets, parading as one-dial receivers, which may possess several, but not all, of the advantages of unified control. A true single-control receiver should have only one tuning dial, and this should maintain each tuned radio-frequency stage and the detector circuit in perfect resonance without requiring the use of supplementary vernier adjustments. A compensating antenna circuit adjustment, which requires setting only once when the receiver is installed, does not disqualify a set from the single-control classification. If, however, such an adjustment must be used each time the listener diverts his attention from the lower to the higher frequencies, or vice versa, the receiver in which it is incorporated is not a genuine single-control receiver but a two-control receiver.

All single-control receivers employing more than one tuned circuit so far devised, use gang condensers mechanically coupled, a system thoroughly covered and controlled under the Hogan patents. The license fees charged under these patents are so moderate, however, that evasion has been practiced only in a few instances, and the development of single-control sets has not been hampered by costly patent litigation.

When seeking to judge the desirability of a single-control receiver, the first discrimination

to be made is as to whether the set under consideration is really a true single-control set. Auxiliary controls are often concealed or camouflaged in order to give the impression that the receiver is tuned by only one manipulation while, in practice, each of these extra controls may require careful adjustment to tune-in a desired station. Even so, a receiver of such design may possess important advantages over the usual two- or three-dial receiver, provided there is only one adjustment of the main tuning dial which brings in each station.

In examining a receiver, therefore, observe every control upon it, no matter how it is labeled. A true single-control set has but two adjustable

adjustments may defeat the buyer's purpose. On the other hand, a well-designed receiver, in spite of verniers, can be a convenience, although their use should be reflected in lower cost of the receiver.

The writer has seen receivers upon which stations may be tuned-in in any position over a span of ten degrees of the main dial by correct manipulation of the verniers, thereby eliminating ease of adjustment, the most desirable quality of the single-control set. On the other hand, other receivers, although requiring vernier adjustments, can be properly tuned to a station at only one certain position of the main tuning control. Such receivers are frequently more convenient to tune than two- or three-dial sets.

Having determined whether the receiver is a true one-control set, or one equipped with verniers but so designed that only one adjustment of the main dial brings in any desired station, the efficiency of the mechanical coupling between the tuning elements should be tested. If there is back-lash, slip, or play in gears, the user can never be certain that his tuning circuits are in complete resonance.

To test the efficiency of the mechanical coupling of tuning elements, select a fairly weak station and tune to it accurately. Note the exact setting of the main dial. Turn the control to the opposite end of the scale and then restore it to precisely its original position. If the weak station is again heard to full volume, the mechanical construction is probably satisfactory. On the other hand, if the station is now found two or three degrees above or below the original setting, play and back-lash are likely to introduce tuning complications.

Some receivers depend upon the friction of adjacent knurled knobs, which may be adjusted separately or operated in unison by one hand at will thereby attaining the single-control ideal. With such a device, the user has choice of complete control over each individual circuit as well as unified control over all of them. The conveni-

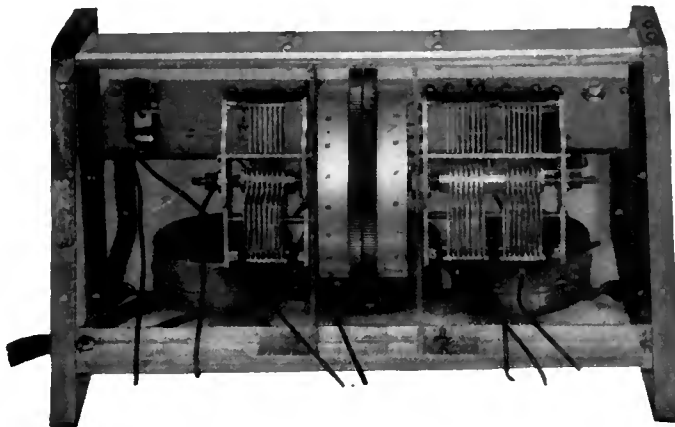

SINGLE CONTROL BY MEANS OF ADJACENT KNURLED KNOBS

dials, *i.e.*, the tuning control and the volume control. In addition, there may be an "on-off" switch in the filament circuit. Any additional verniers, "fine tuning" controls, or compensators take the receiver out of the single-control classification.

The use of vernier controls to correct deviations from exact synchronism among several circuits greatly reduces the cost of manufacture, because close accuracy in making inductances and capacities is thereby dispensed with. If simplicity of control is the objective in purchasing a receiver, too great dependence upon vernier

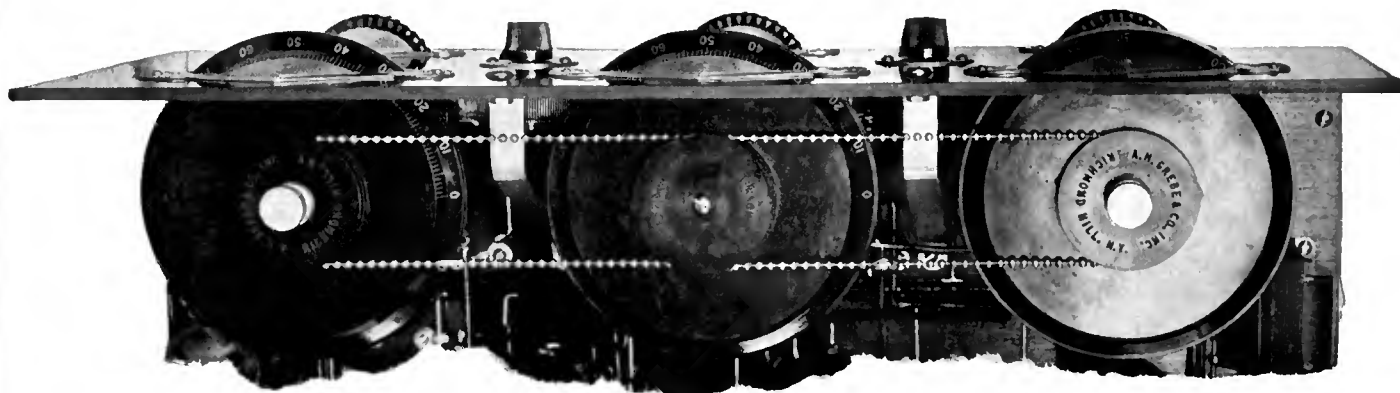

SIMULTANEOUS TUNING OF CIRCUITS BY MEANS OF A CHAIN AND PULLEY SYSTEM

ence of this type depends chiefly upon how closely the circuits are synchronized throughout the scale, once the correct inter-relation between the adjacent knurled knobs has been determined.

The degree of synchronism attained throughout the dial scale with the knurled knob arrangement is easily ascertained. Tune-in a station at the low end of the scale, making fine adjustment of each of the knurled knobs separately. Next tune-in a station preferably of moderate volume at the high end of the scale, by turning the knurled knobs as a group, being careful as you do so not to change the relation between the knurled controls. Having thus tuned-in a station as well as possible, note the volume carefully. Then adjust each circuit separately, noting whether adjustment of the individual circuits is required to secure accurate resonance. If the same relationship between the several knurled knobs which establishes resonance at one end of the dial scale holds for the other, the set is, in effect, a single-control one. On the other hand, if a new relationship between the various knurled knobs is required at different points along the dials, the set may be considered as having as many controls as there are knobs. Then the only gain by the knurled knob over the ordinary dial is in appearance, and in the ease with which it is adjusted by one hand. There are several makes of receivers employing adjacent knurled knobs for control which, when correctly adjusted with respect to each other, can thereafter be operated as a single control. Such receivers represent the last word in convenience and attain simplicity of control without sacrifice in efficiency.

COMPLICATIONS OF SINGLE CONTROL

THE relative cost of obtaining exact synchronism of circuits manipulated by a single control depends on the sharpness of tuning attained for each individual circuit. With radio-frequency amplifiers of high gain and good sharpness of tuning, true single control is rather difficult to secure inexpensively without the aid of verniers. It is a question of precision manufacture, engineering tests, and painstaking design, all of which are naturally reflected in the cost of the receiver. If, at any point along the dial scale, one circuit falls slightly out of step, quality is seriously affected unless the set is fairly broad in its tuning.

There are a number of possible compromises involved in the design of a single-control receiver which account for the wide range in their prices. If quality of reproduction is sacrificed, great sensitiveness and selectivity may be secured at relatively low cost. If on the other hand, sharpness of tuning is sacrificed, a high standard of tonal quality without excessive cost is attainable. If high efficiency, high gain, perfect synchronism, and good quality of reproduction are combined without appreciable sacrifice of any of these qualities, such accuracy in design and manufacture requires that the cost of the set be necessarily high.

Eliminating the most expensive types, which have true single control, sensitiveness, selectivity, and good quality, how may we judge and balance all these diverse qualities in order to make the wisest purchase? To repeat: sensitivity, selectivity, or quality must be sacrificed to secure low cost.

Obviously the most desirable sacrifice is not quality of reproduction, but sensitiveness or selectivity. By choosing a receiver, admittedly a little broad in tuning, you may have single-control simplicity, good quality, and satisfactory volume from local stations at reasonable cost. If troubled by local interference, changes in the antenna installation often minimize the difficulty. A long antenna brings in considerable energy from near-by stations and therefore broadens tuning. By shortening the antenna, selectivity may be increased to a point where interference troubles are minimized. Shortening the antenna reduces sensitiveness as the penalty for improving selectivity.

For the long-distance enthusiast who desires single-control simplicity, sensitiveness, and low cost, there are a number of receivers which, in a measure, attain all of these qualities by introducing regeneration in the radio-frequency circuits. Such receivers usually have a volume control, which, when turned toward maximum, sets the receiver into oscillation throughout the tuning scale, or perhaps does so only at the higher frequencies. These are often radiating receivers of the most pernicious type, feeding oscillations directly into the antenna circuit. Such receivers may be recognized not only by the fact that they flop into vigorous oscillation at the high frequencies, and give a piercing whistle as the dial setting for a station is passed, but also by the fact that stations are often heard at two or three closely adjacent points on the dials. A

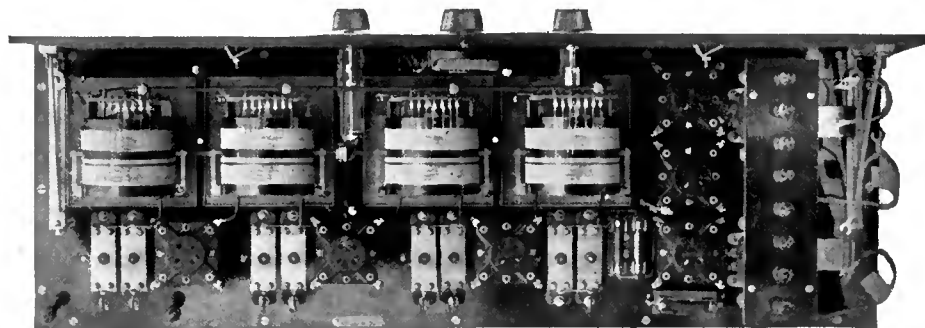

SIMPLIFIED ADJUSTMENT OF SEVERAL TAPPED COILS BY ONE KNOB

circuit closely approaching the regeneration point must be tuned with the utmost accuracy, a degree of accuracy almost unattained by any but the most precise of single-control receivers. Therefore, with single-control near-regenerative sets, stations are frequently heard at each point that the individual stages are precisely in tune with the incoming signal.

Such single-control near-regenerative receivers receive from long distances on the shorter waves, annoy the neighbors for miles around, and give good quality only with high-power local stations.

The better single-control receivers are absolutely non-regenerative. It must be realized that the absence of a tickler or regenerative adjustment is in no wise an indication that the receiver is not regenerative, nor need there be a plate coil feedback inductance or capacity or any other physical evidence of a regenerative circuit. The mere presence of a vacuum tube with elements having electrostatic capacity offers the foundations for a regenerative system. Whether this is avoided by neutralization or by the introduction of losses through counter-couplings or weak couplings is not obvious from any external inspection. Hence the real proof is an actual test of the receiver, particularly at the high frequencies where regenerative effects are most likely to be strongly manifest.

The high-grade, single-control receiver, which is well engineered through effective shielding and correct neutralization of regenerative effects, tunes sharply at both ends of the scale. The stations fall in and out of resonance like a parade as you go up and down the dial scale, with volume proportionate to their incoming signal strength. Such sets represent the last word in efficiency and simplicity of control—the product of precision manufacture and sound engineering. Many such receivers are equipped with three and four stages of radio-frequency amplification, associated with a directional loop.

An effective compromise in the attainment of convenient control without excessive cost is by the use of two controls, designed to operate as one, once their relative settings are fixed. Concentric or adjacent knurled knobs coupled by friction are used for this purpose. These are turned naturally as one, unless the user particularly desires to change their relative adjustment. Usually two controls are used in this way with receivers employing a separately tuned antenna circuit and unified control for the remaining stages of the radio-frequency amplifier. In this case, the input stage is made one of high gain, giving the receiver considerably greater sensitiveness. Different antennas have varying inductance, capacity, and resistance, and these factors affect the correct adjustment of the input circuit, making dual tuning necessary.

The difficulties of varying antenna constants may be obviated by using a loop designed as a part of the set, thus making dual control unnecessary. Other sets are designed for use with a very small antenna, or a large antenna in series with a small capacity, and the various circuits accordingly matched to meet such conditions.

Another method of attaining true single control, is to employ the input stage merely as a collector of antenna energy, without causing it to contribute any great amplification. The input stage is then untuned, a resistance or choke being used across the tube, through which the incoming signals are impressed upon its filament and grid. The remaining circuits, all being fed from the plate circuit of a preceding tube, are easily synchronized without any great manufacturing difficulties. Although contributing little or no amplification, the first tube introduces its share of tube noises and does not materially improve selectivity, a serious disadvantage if there is an excessively strong near-by signal. Considering the low cost of tubes, an inefficient stage is not a great disadvantage from an economy standpoint particularly as it makes possible single-control simplicity. On the other hand, it brings out the fallacy of rating a receiver's power by the number of tubes. The real criterion, by number of tubes, is dependent upon the number of stages of high-gain tuned radio-frequency amplification with which the receiver is equipped.

By this time, the reader will appreciate that judging a single-control receiver lends itself to no simple diagnosis. It is better to thrust aside all considerations of design, unless a most detailed study is made, in favor of a few simple observations and performance tests.

A COMPACT A, B, C POWER-SUPPLY UNIT

This entire unit is constructed on a baseboard measuring 17" x 9". The following parts were used: Dongan power transformer and filter chokes, Tobe filter condensers, Carter output resistance, Yaxley tapped switch, Eby binding posts, Jewell milliammeter. Other parts that might be substituted are indicated in the table given in this article

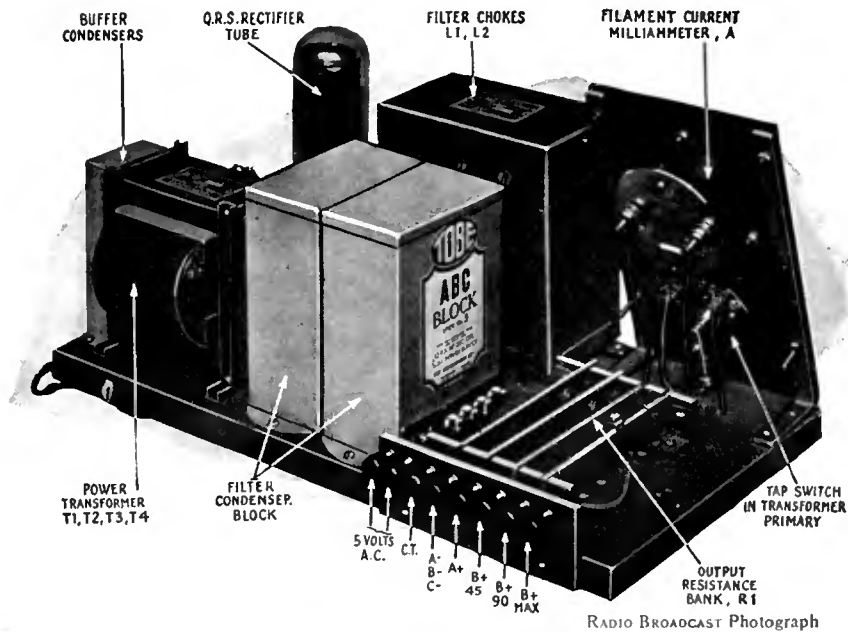

RADIO BROADCAST Photograph

A Lamp Socket A, B, C Device

The Design of a Power-Supply Unit Using the New Q. R. S. High-Current Gaseous Rectifier Tube

By GILBERT EDGAR

IT WOULD be difficult to estimate the amount of engineering research work that in the past has been devoted to the problem of complete a. c. operation of receivers. Probably the first really satisfactory all a. c. receivers were those using 199 tubes in series, with their filaments supplied with rectified a. c. from a B socket-power unit, and with a power tube in the last stage with its filament supplied by raw a. c. directly from a transformer. Such receivers as this were described in the October, 1926, RADIO BROADCAST, but evidently the development was somewhat premature, for not many such sets were built. Since then the question of a. c. operation has become a common subject of discussion and there is evidently considerable interest in this topic.

Two months ago, in the advertising pages of this magazine, there was announced a new rectifier tube, manufactured by the Q. R. S. Music Company, which could be satisfactorily used to supply complete power to a receiver from the power mains. One advantage that accrues from the use of this new tube is that 201-A type tubes may be used in the receiver, their filaments being wired in series. To wire a receiver with the filaments in series is not any more difficult than wiring them in parallel, and it is also an easy matter to rewire an existing receiver for series filament operation. The energy required by the new rectifier to supply A, B, and C voltage to a receiver is sufficiently low so that a. c. operation is not only convenient but also economically practicable. The audible hum heard in the output of a receiver operating from an A, B, C power unit is no greater than that experienced when the same receiver is operated with a storage-battery supply for the filaments and a B socket-power unit to supply the plate voltage. For normal operation the device must supply $\frac{1}{2}$ ampere (250 milliamperes) to light the filaments of the tubes and it must also supply plate current, so that the total load is generally about

280 to 300 milliamperes. This value of current is much greater than is found in a power unit designed to supply only plate voltage to a receiver and, therefore, the various chokes, condensers, and resistors used in such a unit cannot be used with this new tube. It is necessary that the various parts used have characteristics adapted to the use to which the device is to be put. The main power transformer has four windings, as shown in Figs. 1 and 2. T_1 is a primary preferably tapped for line voltages between 100 and 120; T_2 is a 5-volt winding capable of supplying $\frac{1}{2}$ ampere for a 171 type power tube; T_3 a high-voltage secondary winding capable of delivering 375 volts each side of the center tap, and T_4 is a 4-volt winding to supply 5 amperes to a small ionizer designed to lower the internal resistance of the tube. The two filter coils, L_1 and L_2 , must carry all the filament and plate current for the receiver and, at this very high current drain, they should have an inductance of between 3 and 5 henries. The condensers in Fig. 1 should have the following characteristics:

- | | |
|---|--------------------------|
| C_1 —0.2-mfd. Buffer Condenser, | } 600 Volts. |
| C_2 —0.2-mfd. Buffer Condenser, | |
| C_3, C_4 —0.1-mfd. Condenser, | } D. C. Working Voltage. |
| C_5 —5-mfd. Condenser, 400 Volts D. C. Working Voltage | |
| C_6 —10-mfd. Condenser, 400 Volts D. C. Working Voltage | } D. C. Working Voltage |
| C_7 —1-mfd. Condenser, 200 Volts D. C. Working Voltage | |
| C_8 —1-mfd. Condenser, 200 Volts D. C. Working Voltage | } D. C. Working Voltage |
| C_9 —1-mfd. Condenser, 150 Volts D. C. Working Voltage | |

The resistances used in the output system are required to carry large amounts of current and special units are therefore necessary which are capable of dissipating considerable power. The resistance R_1 should be capable of carrying about 350 milliamperes and should have a total resistance of about 800 ohms. It is preferable that this resistance should be semi-variable because its value will depend upon the number of tubes in the receiver. Various manufacturers have designed transformers, chokes, condensers, and resistors especially for use with the QRS tube and a complete list of those companies making them is given in the table on page 154.

To determine the characteristics of the device, a complete power unit was constructed in the RADIO BROADCAST Laboratory in accordance

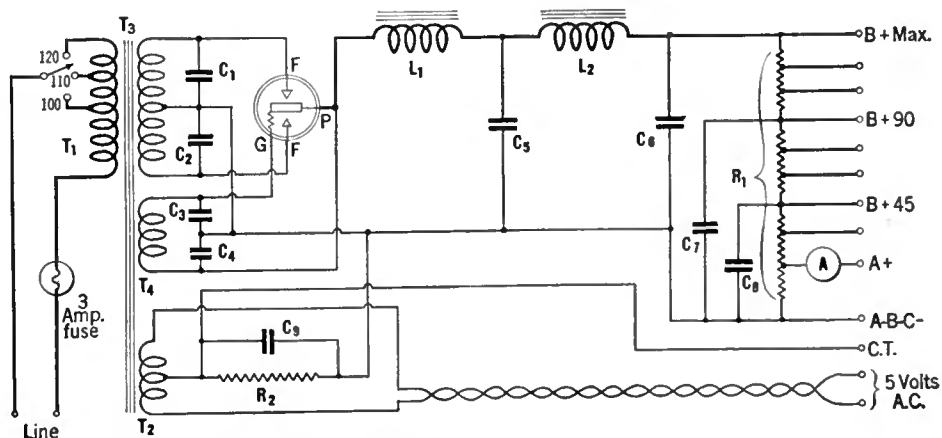

FIG. 1

with Fig. 1. Data were then taken on the unit, a photograph of which can be seen on page 153, to determine the input power and output voltage at various loads. In Fig. 3 is given a curve showing the power required by the device at various current drains. The total current drain from the device is equal to 250 milliamperes (that required to operate the series filaments of the tubes in the receiver) plus the total plate current required by all the tubes. Therefore if a receiver required 30 milliamperes of plate current, the total current drain from the device would be 250 milliamperes for the filaments plus 30 milliamperes for the plates, or a total of 280 milliamperes. The input power at this current drain is about 127 watts, which is approximately the power which the device requires when it is used to operate an ordinary five-tube receiver using a 171 type power tube. In Fig. 4, curve A, are plotted the data taken to determine the voltage delivered in normal operation. It is evident from the curve that, with a total plate-current load of 30 milliamperes (average load of a five-tube receiver), the unit will deliver about 200 volts, which is sufficient to satisfactorily supply plate and grid voltages for a 171 type tube. Curve B in Fig. 4 was made with transformer winding T_4 disconnected so that the ionizer filament was not functioning and, under such conditions, the device only de-

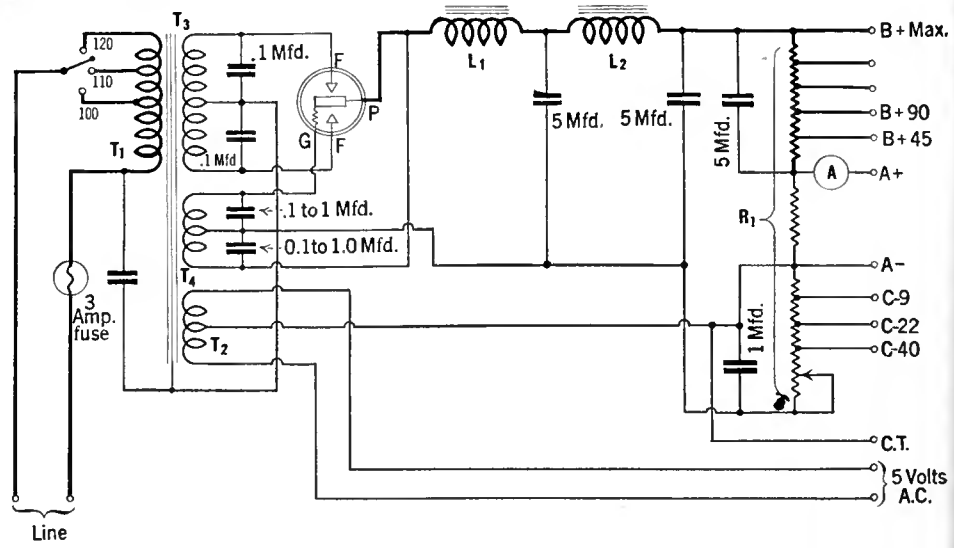

FIG. 2

livers 145 volts with a plate load of 30 milliamperes. It is evident, therefore, that this tube will function without the ionizer but that under such conditions the output voltage is lowered.

OUTPUT SYSTEM

IT IS necessary to use at the output end of the unit a voltage divider, or potentiometer arrangement, to obtain the various voltages required by the receiver. The simplest, and in many cases an entirely satisfactory arrangement, is that shown in Figs. 1 and 2, in which the A and B voltages are taken from various taps along a tapped resistance, R_1 .

The B voltages obtained by using such an arrangement are constant because the current flowing through the resistance due to the filament load is very much greater than the current drawn by the plate circuits from the various taps and, therefore, the plate-current is of a negligible quantity compared to the total current flowing through the resistors. With some receivers, however, especially those using audio amplification other than transformer coupling,

some difficulty will frequently be experienced due to "motor boating," in which case it is necessary to use a different output arrangement. Complete information regarding the various output arrangements that should be used in such circumstances will be found in the article starting on page 157 of this issue.

C bias for the 171 tube is best obtained by connecting a resistance, R_2 , in series with the center tap of the filament transformer supplying the filament of the 171 (See Fig. 1), while C bias for the other tubes is obtained by connecting resistances in series with their filaments at the correct points, as shown in the circuit diagrams accompanying the article beginning on page 157. A lead is brought out from the center tap of the filament winding T_2 to a terminal marked CT, and

this terminal should connect to one side of the loud speaker jack in the receiver. In this way, the signal energy flowing through the loud speaker is brought back directly to the filament of the 171 tube, and this tends to make the operation of the receiver more stable.

PARTS FOR THE A, B, C UNIT

SEVERAL manufacturers are now putting out parts capable of meeting the rigid requirements of high-current power-supply devices. Parts made by the following manufacturers, and suitable for such devices as that one described here, are approved by RADIO BROADCAST Laboratory.

TRANSFORMERS AND FILTER CHOKES: Dorgan, Thordarson.
 CONDENSERS: Aerovox, Dubilier, Fast, Muter, Wilson Electrical Laboratories, Tobe, Potter.
 RESISTORS: Aerovox, Allen-Bradley, AmSCO, Carter, Centralab, Clarostat, Electro-Motive Engineering Corporation, Lynch, Ward-Leonard.

A complete A, B, C device is as simple to construct as an ordinary B power unit and is no more difficult to get operating properly. The entire device can be constructed on an ordinary baseboard. It will be found advisable to mount the baseboard on small rubber feet so that most of the wiring can be done under the baseboard. Use well insulated wire in the construction because the transformer supplies rather high voltages. The two leads from transformer winding T_2 supplying 5 volts a. c. to the filament of the 171 should be twisted together. In constructing a unit do not so arrange the apparatus that the filter chokes and transformer cores are near and in line with each other but endeavor to leave a space of several inches between them and place them out of line or at right angles to each other. The power unit shown schematically in Fig. 1 has been on test for some time, and has given very good results. The circuit diagram in Fig. 2 was supplied by the Q.R.S. Company. Very excellent results have been reported from the use of this latter circuit with all receivers.

For complete details regarding the correct manner in which to wire a receiver for series filament operation the reader is referred to the article starting on page 157 of this issue in which the subject is carefully explained. Pertinent data on this subject also appeared in articles in the two preceding issues of RADIO BROADCAST.

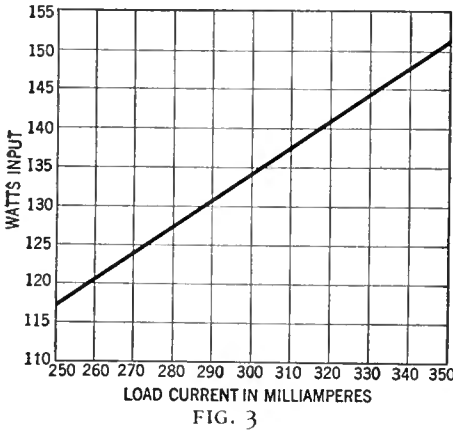

FIG. 3

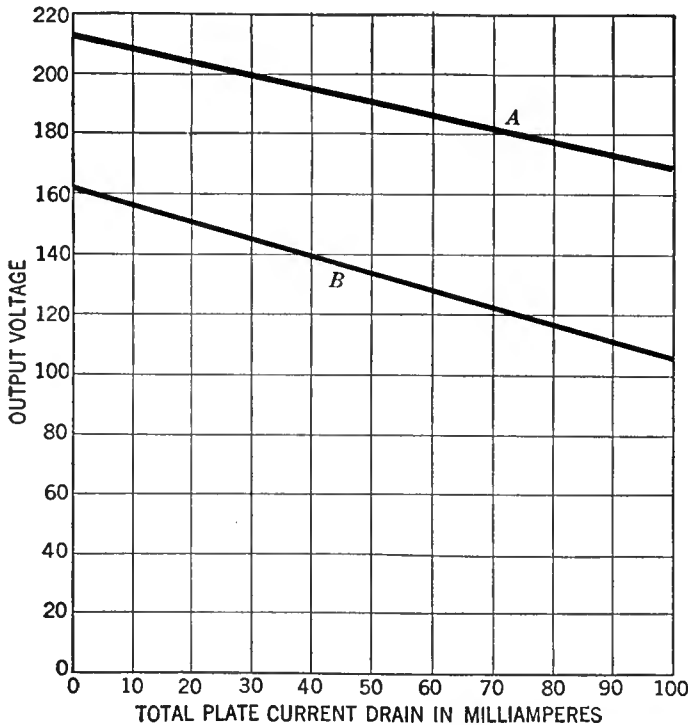

FIG. 4

An A, B, C Power-Supply Unit for 201-A Type Tubes

A Power Device Which Provides for the Complete Elimination of All Batteries in a Radio Receiver—Some Design Hints and Precautionary Measures

By ROLAND F. BEERS

THE purpose of this article is to describe a satisfactory unit for supplying A, B, and C power to any radio receiver employing 201-A type radio tubes. It is the writer's belief that this article describes the first really satisfactory method, for the home-constructor, whereby complete radio power for 201-A tubes can be obtained from one unit. It is true that there have been separate A and B units in use for some time, and that their performance has been above reproach. For one who desires simplicity, however, the new method has many advantages to offer. Here is complete radio power from the light socket, without batteries or liquids, and the unit when completed requires absolutely no attention.

To use the power unit described necessitates that the filaments of the tubes in the receiver be wired in series. The writer has explained this method of connection in the two preceding articles of this series, and many diagrams and other data were given showing how to wire a receiver for series filament operation and how to obtain C bias for the various tubes; precautions necessary in using such an arrangement were also outlined. If the reader is not thoroughly familiar with the subject, the details thereof may be found on pages 33 to 35 of the May RADIO BROADCAST, and on pages 101 to 103 of the June issue. The writer has used series filament connection in practically all of the fundamental radio circuits and has found no reason why it cannot be used with any type of existing receiver if proper precautions are taken. An article starting on page 157 of this issue explains how the supply unit described here may be adapted to various well-known circuits.

The entire A, B, C power supply unit is built around the new Raytheon Type BA-350 mA. rectifier tube. This new development is a full-wave device, operating upon the principles of gaseous conduction. It has no filament. The principles involved in the design of this new unit are an extension of the fundamentals of all Raytheon gaseous rectifiers, and reveal improvements which increase the efficiency of these devices

to a remarkable degree. These improvements were really a necessity, in order that a rectifier of reasonable proportions might be constructed. The loss in a device of this type takes the form

of heat, which must be radiated by the glass bulb of the rectifier, and if the power losses were excessive, it would be essential to build a glass bulb several inches in diameter in order to keep the operating temperature at a safe value. By the improvement in the efficiency, it has been possible to keep the size of the BA rectifier down to moderate proportions.

The full load rating of the tube has been placed at 350 milliamperes and 200 volts d.c. output at the terminals of the filter circuit. This rating, which includes the watts which are bypassed through the filter circuit, is sufficient to operate any receiver having up to ten tubes and a power amplifier. A minimum life of 1000 hours may be expected from these new rectifiers provided they are not overloaded or abused. Fig. 1, "C," shows the characteristic of a typical BA rectifier used in a complete power unit. It should be noted that the voltage is practically constant at all loads and, therefore, if a tube is suddenly removed from the circuit and the load as a result drops from something around 300 milliamperes to about 20, the voltage will not rise excessively and endanger the filter condensers.

In other words, the voltage remains practically constant independent of the load and, therefore, there is almost an unlimited current capacity in the device. This large reserve of power is very desirable as long as it does not exceed the useful power required by the radio receiver, and means must evidently be taken to limit the output of the power unit to this useful value. It is therefore necessary to use special methods of design in the power transformer and filter circuit, and it is consequently not feasible to recommend that the radio constructor build his own power transformer or filter. Their characteristics are very unusual, and it is doubtful if the average constructor could meet the requirements of the design in home-built units. Manufacturers have cooperated with the designers of the BA rectifier, and have affected the design which is best suited for the purpose.

The power transformer is rated at approximately 175

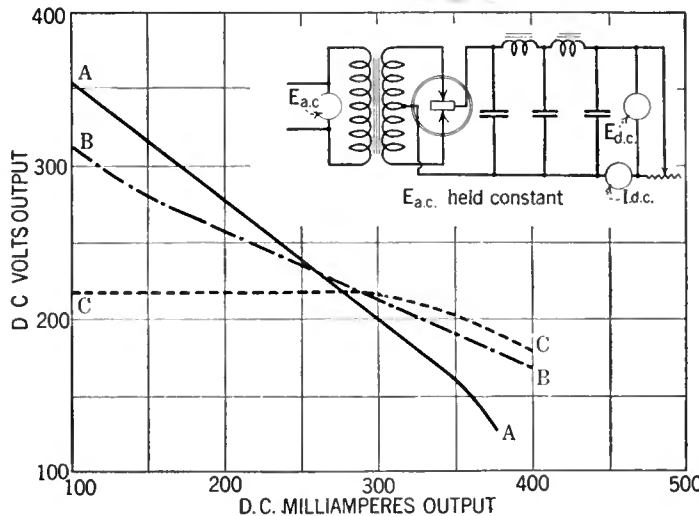
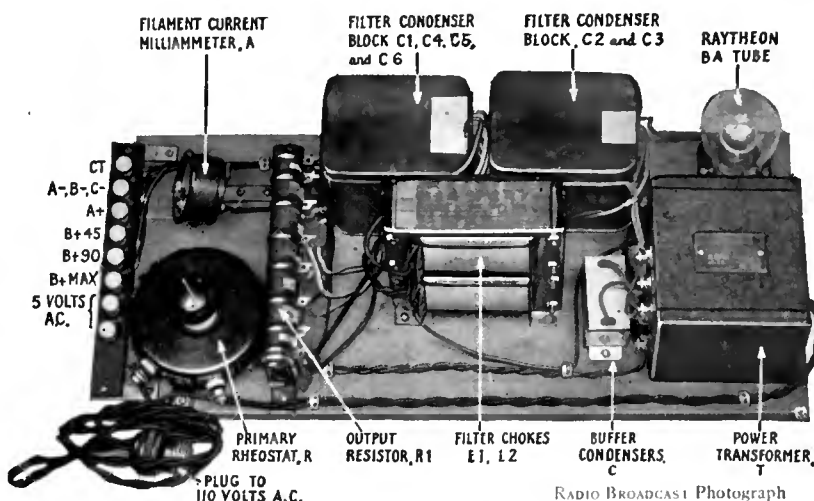

FIG. 1

Three output voltage curves for three different experimental designs of the Raytheon BA rectifier, curve C being the design that was finally adopted. Note that the output voltage is constant from 0 to 300 milliamperes. Curve A is a very unsatisfactory one for if a tube is suddenly removed from a receiver and the load on the power unit tube reduced to practically zero, the voltage will rise to a comparatively high value and endanger the filter condensers



A COMPLETE A, B, C POWER SUPPLY

Using a Raytheon BA tube. This particular unit uses a Thordarson transformer T, Thordarson choke coils L_1 and L_2 , Dubilier condensers type BA2 for C_2 and C_3 , type BA3 for C_1 , C_4 , C_5 , and C_6 , and Type BA1 for the two buffer condensers, C. The primary rheostat R, and the tapped output resistance R_1 , are made by Ward-Leonard, while the 2000-ohm C bias resistance R_2 (this resistance cannot be seen in the photograph) is a 2000-ohm Tobe Veritas resistance. The filament milliammeter, A, is a 300-milliamperer Weston model 506 meter. Eight X-L binding posts are used and the unit is wired with Kellogg Switchboard Company hook-up wire. It can be built at a cost of about \$90.00

watts; it has a secondary winding delivering 320 volts per side for the BA rectifier, and a filament winding of 5 volts at 0.5 amperes for a 171 type power amplifier tube. The choke coils, L_1 and L_2 , are of special design, and have a minimum inductance requirement of 10 henrys at 350 mA. direct current. Their d.c. resistance lies between 150 and 200 ohms each. Ordinary choke coils cannot be used in this circuit on account of the large amount of direct current which must flow through the windings. The transformer and chokes are offered by the Acme Apparatus Company, Cambridge, Massachusetts; the Dongan Electric Manufacturing Company, Detroit, Michigan; and the Thordarson Electric Manufacturing Company, Chicago, Illinois.

The normal operating voltage of the filter condenser block should be at least 400 volts d.c. The two buffer condensers in series across the secondary of the power transformer have a capacity of 0.1 mfd., and an operating voltage rating of 1000 volts d.c. (Various manufacturers have arranged to supply condensers that meet these recommendations. At the present time they are being made by Dubilier, Tobe, Aerovox, Muter, Mayolian, Potter, and Fast, and very likely by the time this article appears in print other manufacturers will also be making them.—*Editor.*)

The resistance units used in the device are also special for they must have a wattage rating much in excess of that necessary for a resistance used in an ordinary B socket power unit. Excellent resistances have been designed, however, and are being made by Clarostat, Carter, Ward-Leonard, Centralab, Aerovox, Amsco, Lynch, and the Electro-Motive Engineering Corporation.

HOW THE UNIT FUNCTIONS

A BRIEF explanation of how the A, B, C unit functions will be interesting. The alternating current from the power transformer passes through the BA rectifier, where it is converted into pulsating direct current. This pulsating current may be considered as consisting of a pure direct current and an a.c. component. It is the function of the filter circuit to absorb or bypass the alternating current and to pass on only pure d.c. Approximately 60 mA. of a.c. are bypassed through the filter circuit for a d.c. output of 350 mA. Having obtained a uniform and

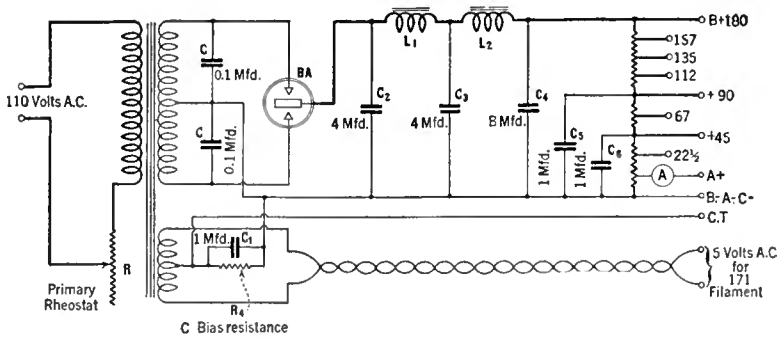

FIG. 2

All the plate-, filament-, and C-battery potentials required by a receiver can be obtained from an A, B, C socket-power unit constructed in accordance with the circuit diagram given in this diagram. The various A and B voltages are obtained across a tapped fixed resistance in the output. A 171 power tube is supplied with 5 volts a.c. for its filament, while the C bias for this same tube is obtained by means of a voltage drop across resistance R_1 . "R" is the primary rheostat which compensates variations in the line voltage

smooth direct current at the output of the filter circuit, it is now our purpose to dispose of it with reference to the radio receiver, in the proper voltages and currents.

This is effectively accomplished in one of two ways. The first is to use a tapped fixed resistance across the output of the filter circuit as shown in Fig. 2. This unit has a resistance of about 470 ohms, and is supplied with a plurality of taps so that a great range of voltages is available. By the use of this single resistance all the plate and filament voltages are obtained with little difficulty, and since the points at which to take taps can be easily determined in designing the resistance, the method has the advantage that the voltages available at each tap are fairly definitely known. All the plate voltage taps which are used should be bypassed to A minus with a 1-mfd. condenser to prevent undesirable coupling effects.

Fig. 3 shows an alternative means of obtaining the proper plate and filament voltages, and in this arrangement practically any voltage from zero to maximum can be obtained from each voltage tap. This latter system is therefore quite flexible, but it has the disadvantage that the voltages are not known unless a voltmeter is available to measure them. In Fig. 3 the voltages are obtained through variable resistance units, R_2 and R_3 , such as Clarostats, and filament control is obtained through a fixed or semi-variable resistance, R_1 . In such an arrangement, R_1 must be capable of carrying $\frac{1}{2}$ ampere.

The most important control resistance is that shown in the primary of the power transformer and marked "R" in Figs. 2 and 3. The purpose of this resistance is to offer a degree of control over the primary line voltage and it will be found most valuable in obtaining satisfactory operation from the entire unit. The maximum value of this resistance should be about 15 ohms, and its minimum value about 4 ohms. In the case of the Acme transformer, a 4-ohm resistor is mounted on it so that the additional resistance may be obtained by the use of a 10- or 12-ohm rheostat. The rheostat must be capable of carrying $1\frac{1}{2}$ amperes continuously without undue heating. Rheostats for

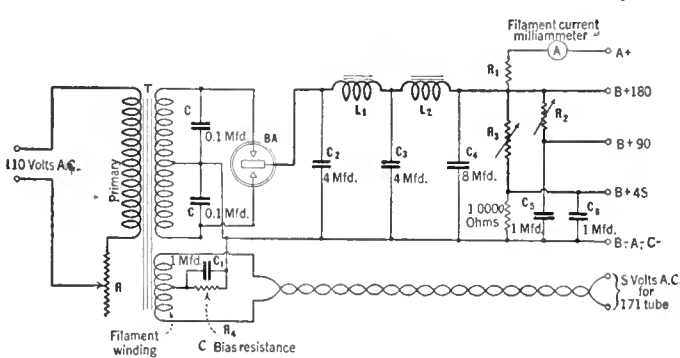

FIG. 3

This circuit diagram shows an arrangement using variable resistances in the output so that various voltages can be obtained whereas, in Fig. 2, the various voltages were obtained from taps in a fixed resistance. The primary rheostat, "R," should be adjusted so that the milliammeter, "A," in the filament circuit, reads between 240 and 250 milliamperes. The BA tube when it is first turned on will glow brilliantly but this glow should disappear in a few seconds

this purpose are made by Clarostat and Ward-Leonard.

If the experimenter desires, he may build up a power supply unit of this type as an accessory to his series filament radio receiver, or he may construct it as an integral part of the receiver. The performance of the unit will be the same in either case and it is simply a matter of choice which type of power supply the home constructor will build. The photograph shows the manner in which the various parts are assembled. Particular attention should be paid to the arrangement of the power transformer and the filter chokes, so that the effects of good filtering will not be offset by the cores of the filter chokes becoming saturated with leakage flux from the power transformer. Place the iron cores at right angles or out of line with each other.

In building a case or housing for the power supply unit, it should be borne in mind that there is a considerable amount of heat to be dissipated, and that sufficient ventilating means must be employed for this purpose. It is therefore not advisable to build a completely enclosed cabinet which will prevent the circulation of cool air throughout the interior. The rectifier bulb must not be allowed to become over-heated, neither must the transformer nor control resistances be prevented from radiating the normal amount of heat.

The operation of a series filament receiver supplied with the Raytheon power unit just described is not greatly different from that of the ordinary type of receiver. Variations in filament current of the order of 10 per cent. have very little effect upon the output of the radio receiver. In normal operation the Raytheon BA rectifier will be found to run fairly warm, as its efficiency is dependent upon a certain amount of heat within the rectifier, but if the bulb of the rectifier is hot enough to sizzle when it is touched with a moistened finger, it is evident that there is some overload on the rectifier, and the cause of this should immediately be determined. It may be caused by a blown condenser in the filter circuit, or by a short-circuit of the output. Such a condition as this would of course be otherwise manifest by faulty reproduction, or total failure of the output voltage. Any such overload on the rectifier should be immediately removed in order not seriously to shorten its life. If a red-hot spot is seen within the rectifier at any time, it is direct proof that there is a short-circuit in the output of the power unit, which should be corrected at once. The power transformer will run slightly warm under normal full load and the filter chokes should show a very slight rise in temperature. The output resistance units will all run approximately 190° F. If a higher temperature than this is attained it is not safe for inflammable material near by, but if the resistance is housed in a metal container it may be considered reasonable if these units do not exceed 300° F. It is of course a matter of common sense that the resistor units should be mounted in such a position that the hot surfaces do not come in contact with inflammable materials.

During the normal operation of the power unit it may be noticed that there are slight variations of the filament milliammeter which will be caused by fluctuations in the a.c. line voltage. It will be found convenient to maintain average filament currents at a figure between 240 and 250 mA., so that a 10 per cent. change will neither overload the filaments nor cause the amplification to go below normal values.



RADIO BROADCAST Photograph

APPARATUS FOR A, B, C POWER UNITS

The equipment shown in this photograph, in addition to that specified for the units in the two preceding articles, has been especially designed for A, B, C devices. (1) Potter filter condensers; (2) Clarostat variable resistances, including the new power Clarostat for controlling the primary voltage; (3) Raytheon BA tube; (4) John E. Fast filter condensers; (5) Aerovox filter condensers; (6) Q. R. S. 400-mil. tube; (7) Acme filter chokes; (8) Amsco A, B, C resistor kit; (9) Lynch A, B, C resistor; (10) Acme power transformer; (11) Centralab A, B, C resistor kit

Receiver Design for A. C. Operation

Rewiring the Filament Circuits of Some Popular Receivers to Conform With the Requirements for A, B, C Socket Power Supply—New Circuits for the "Lab," "Universal," Browning-Drake, and Neutrodyne Receivers

By HOWARD E. RHODES

IN THE two preceding articles there has been given information regarding the construction of A, B, C power units, using two different rectifier tubes. In this article we will explain how to apply these power units to various receivers. The circuit diagrams of these two power units differ in some details but fortunately the output connections on both are exactly the same and, consequently, there is no need to differentiate between them in applying them to receivers. A receiver designed for use with the unit using the Raytheon tube will work equally well if supplied from the Q.R.S. power unit. Therefore, in the various diagrams in this article we will not include the power unit, and the reader should understand that in all cases the various terminals on the receiver are to be connected to the corresponding terminals on the power unit.

Tests have been conducted in the laboratory

using a five-tube receiver consisting of a stage of r.f. amplification, regenerative detector, and a three-stage double-impedance amplifier. A regenerative receiver using this type of amplification is frequently difficult to get working properly with a power-supply unit because of a marked tendency to "motor-boat," and it was felt that, if this receiver could be made to function satisfactorily with an A,B,C power unit, any other receiver would surely work satisfactorily. It was found that the receiver "motor boated" badly using the output circuit shown in Fig. 1, A, although when a two-stage transformer-coupled amplifier was substituted for the double-impedance affair, results were excellent. To prevent "motor boating" with the impedance amplifier, the output potentiometer circuits shown at B, C, D, or E, Fig. 1, had to be used.

The output arrangement indicated at "B"

differs from the output arrangement shown at "A" in that the filament and plate circuits have been separated. In this arrangement R_1 should have a value of about 700 ohms and be capable of carrying the filament current, and R_2 may be a fixed resistance of about 4000 ohms capable of carrying 50 milliamperes. The total resistance of R_3 , R_4 , and R_5 should be about 10,000 ohms with taps at various points for different plate voltages. The three latter resistances can be obtained from Amsco, Ward-Leonard, Lynch, or other reputable manufacturers.

In the arrangement shown at "C" the filament current and plate voltages for all the tubes except the detector are obtained from a common resistor. The detector plate voltage, however, is obtained from a separate resistor, R_1 , which should have a value of 40,000 ohms. A variable resistance, such as the high-range Clarostat, may

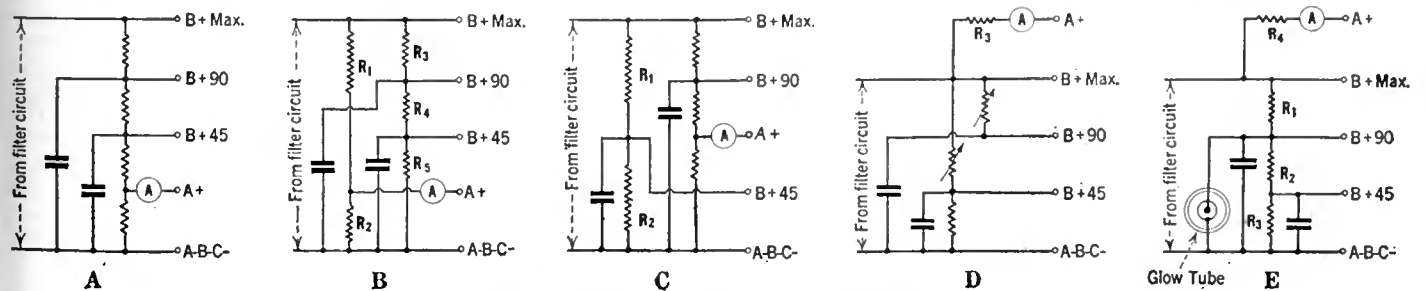

FIG. 1

also be used here. R_2 is a discharge resistor with a value of 10,000 ohms.

At "D" is shown an arrangement using variable resistances to obtain amplifier and detector voltages. Due to the use of two separate resistances for this purpose there is little or no common coupling and, therefore, freedom from "motor boating" is obtained. The filaments are here supplied from a separate resistance, R_3 , which should be capable of carrying the filament current. All of these resistances may be obtained from the American Mechanical Laboratories in the Clarostat "A" kit, or they may be obtained as supplied by Centralab.

At "E" we have an arrangement using a glow tube which has also been found very effective in preventing "motor boating." In this circuit, R_1 should have a value of 1500 ohms, R_2 a value of 4000 ohms, and R_3 a value of 6000 ohms, and R_4 must be capable of carrying the filament current. A circuit somewhat similar to this has been worked out by Amsco and a drawing showing it is being supplied with the resistors which they have designed for the job.

ADAPTING POPULAR CIRCUITS

IN FIG. 2 is the circuit diagram of the four-tube "Lab" receiver, described in the November, 1926, RADIO BROADCAST, revised for series filament operation. The order of the tubes from the A plus terminal is r. f. tube first, first a.f. tube

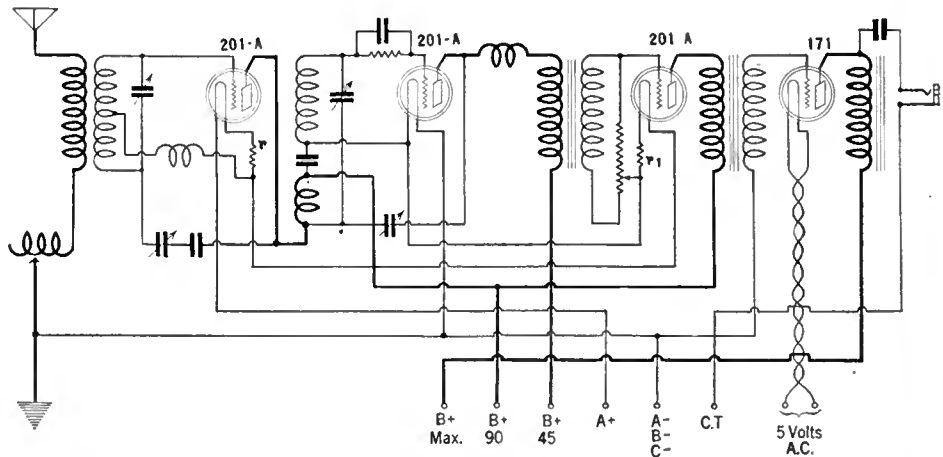

FIG. 2

brought down to two a.c. filament terminals, and it is absolutely necessary that the output circuit shown in the plate circuit of the 171 be used and that one side of the loud speaker jack connect to the center tap, CT, as indicated. The negative A should be grounded. No trouble should be experienced with this receiver due to "motor boating" and, for this reason, any output arrangement indicated in Fig. 1 may be used. However, in the event that the "Lab" receiver

In Fig. 3 we have a diagram of the new "Universal" receiver, described in RADIO BROADCAST for December, 1926, wired for a.c. operation. The order of filaments is the same as in the case of the "Lab" receiver, and the two resistances, r and r_1 , should each also have a value of 18 ohms. This receiver will operate satisfactorily using any of the output arrangements indicated in Fig. 1.

In Fig. 4 is given the circuit diagram of an all-

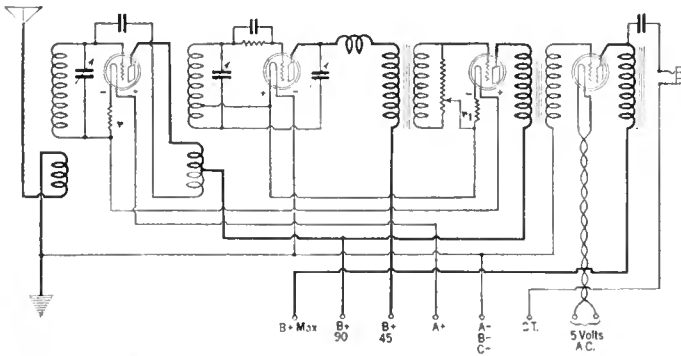

FIG. 3

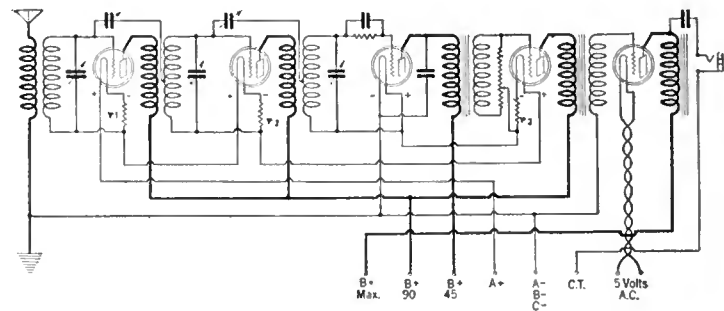

FIG. 4

second, and detector tube third. The output tube is, of course, supplied with raw a. c. Resistances r and r_1 in the filament circuit are used to obtain grid bias for the r. f. and first audio tubes respectively. They should both have a value of 18 ohms (such as Carter type H-18), which will give each tube a grid bias of $4\frac{1}{2}$ volts. The Carter Radio Company makes a complete line of resistors for use in this connection and they are very satisfactory. The two leads from the 171 tube filament should be twisted together and

has been constructed using a different type of audio amplifier, such as an impedance- or resistance-coupled circuit, it will very likely be necessary to use a special output arrangement in the power unit to prevent "motor boating." Separating the detector plate voltage supply from the rest of the A and B circuits, as shown in B, Fig. 1, will generally eliminate the trouble, but if "motor boating" is very persistent it will be necessary to use the glow tube arrangement shown at "E" in Fig. 1.

a.c. neutrodyne receiver. The resistances r_1 , r_2 , and r_3 should each have a value of 18 ohms, which will give the two r. f. tubes and the first a. f. tube a grid bias of 4.5 volts. The receiver will function satisfactorily with any of the output arrangements indicated in Fig. 1.

Fig. 5 is the circuit diagram of the impedance-coupled Browning-Drake receiver which was described in the September, 1926, RADIO BROADCAST, now connected so as to be satisfactory for use in conjunction with A, B, C power units. The order of the filaments from the A plus terminal is r.f. tube first, second a.f. tube secondly, first a.f. tube third, and detector finally. The resistance r_1 should have a value of 12 ohms; r_2 should have a value of 4 ohms, and r_3 , a value of 12 ohms. The negative A should be grounded and should also connect through a 0.5-mfd. fixed bypass condenser to the lower side of the coil in the antenna circuit. It is unlikely that this receiver will give satisfactory results with the output circuit arrangements of the power unit shown at "A," "B," or "C," Fig. 1. For this set it will be preferable to use the circuit arrangement indicated at "D" or "E."

The 15,000-ohm resistance, r , in the plate circuit of the r.f. tube, is used to cut down the voltage to about 65 from 90 to prevent any possibility of trouble due to oscillations in the r.f. amplifier. A. C. operation can also be applied to other receivers by following the suggestions given in this article.

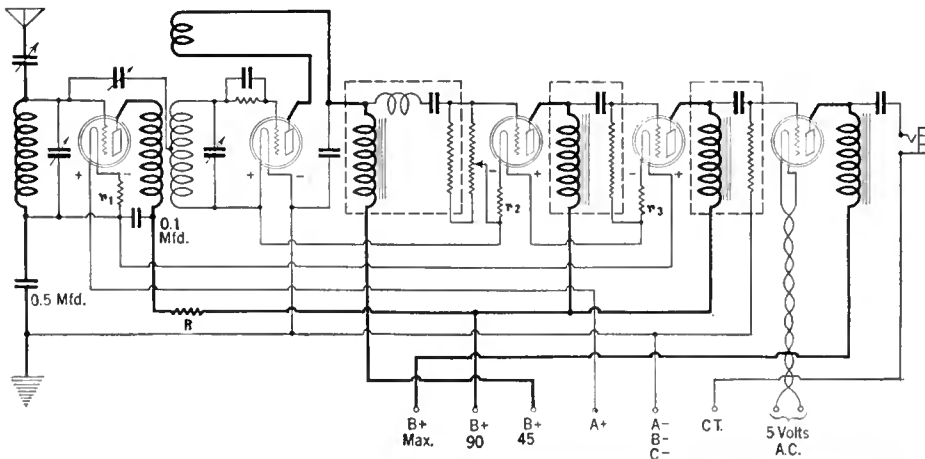

FIG. 5

THE LISTENERS' POINT OF VIEW



Conducted by John Wallace



Sunday Broadcasting Is Five Years Behind the Times

ALAS, what a sad affair is Sunday daytime broadcasting! In respect to its other hours of duty, radio has progressed remarkably since its earliest days, but Sunday has lagged behind and is as bad as it ever was. Sunday of all days!—the very day when radio should be neatly polished as to boot, washed as to ear, and comporting itself at its very best—the one day of the week when the man of the family who foots its bills is on hand to listen to it.

Before commencing to write this article we led ourself to a darkened room, sat ourself down in a not too comfortable chair, and forced ourself with the most hurculean efforts of will to ponder solemnly for one half hour as to the reason why. The conclusion of that thirty minutes of terrific concentration found us still entirely in the dark—in both senses. It is still utterly inexplicable why radio stations, the country over, and without exception, should put forth their very worst at the one time of the week when it would be most advantageous for them to put forth their very best. We pass the question on to you: Why?

That they blare forth either their worst—or nothing at all—is a matter of record, which record we shall presently submit to you. We are concerned in this present discussion simply with the program offerings of Sunday mornings and Sunday afternoons, that is, all those up to 6:00 p. m. The day time broadcasts may be divided into two kinds: First, those which are holy; and second, those which are not holy. In both departments a very low level of quality exists.

But to consider them one at a time, the non-holy offerings first. The complaint on this score can be briefly put—*where are they?* The few offerings aren't so bad, a couple of them are really good, but they are so lamentably few. The good soul who gets himself up early of a Sunday morning to go to church or to till the garden often finds himself with a couple of idle hours on his hands while he awaits dinner. Is there anything entertaining for him to listen to? There is not—unless he be interested in a radio reading of the funnies. It is practically impossible to get any respectable dinner music, unmixed with vocal solos, around Sunday noon, though on any given evening of the week a dozen dinner orchestras are available. In the afternoon he is little better off. In summer, few people are hanging around their parlors—one look at the roads proves that point. But in winter there are millions of potential listeners during the afternoon hours. Nevertheless the winter Sunday afternoon programs are no better than the summer ones.

We do our listening near Chicago and here is what is available to us on an average Sun-

day: Nothing at all before 1:15 when WGN offers a forty-five minute program from Lyon and Healy's; a string quartette from WMAQ at 1:45; a couple of mediocre orchestras from unimportant stations at 2:00 o'clock; at 3:00 (until recently) a very good concert by the Chicago Philharmonic Orchestra through WGN (but unfortunately its



A RELIGIOUS SERVICE AT WMBI, CHICAGO

season ended in April); at 4:00 o'clock a fair program from WBBM, and at 5:00 another fair one from WEBB.

We do not argue that these offerings, and some by other stations, are not likely to be good. But

we protest that our choice is so limited. The 2:00 to 6:00 hours on Sunday should discover us choosing from a plethora of good things; instead it more often finds us giving up a fruitless search in disgust and switching off the receiver.

Since daytime distance reception doesn't exist we can't be sure whether listeners in the East and in the West are as bad off as we are, but a reading of the Sunday program listings in those sections leads us to suppose so. A careful perusal of the New York programs for a recent Sunday in April suggested only five programs that we would consider tuning-in: WJZ at 2:00, Roxy and his gang; WGL at 3:00, Orthophonic Musicale; WPG at 3:15, Organ Recital; WOR at 4:30, Studio Guild Program; and WRNY at 4:30, Clarinet Quartette. Even then it would be a gamble whether all or any of them would be worth while.

In a west coast program magazine we could find, of the twenty-seven stations listed, only four programs that seemed to promise any interest whatsoever: KFWI at 1:00, Vocal Selections; KFWB at 2:00, Organ Recital; and KGW at 1:00 and 4:00, Orchestra.

Well, so much for the non-holy Sunday offerings—the only trouble with them is that they ain't!

As to the religious broadcasting, we hesitate to stick our foot into a so highly controversial subject, but perhaps we can maintain a perch on the fence and prod about in the material with a long and disinterested stick.

No one can deny that there is plenty of religious broadcasting. Turn to any part of the dial at any part of the day and hear rantings of all kinds and descriptions. As to whether all this talk accomplishes a very tremendous or very negligible good, it is decidedly out of our province to opine. As a radio program reviewer our concern is solely that the listeners, as a body, be given their money's worth in programs. Unquestionably there are great numbers of individuals interested in furnishing religious broadcasts. It is likewise unquestionable, if not so easily demonstrable, that there are great numbers of persons interested in hearing religious broadcasts, even such (to us) irritating bombast as that laddled out by the Reverend Bradley (WMAQ).

Religious broadcasting, as now done, should be continued. We would be the first to protest if the Ultra-Advanced-Thinkers should attempt to eliminate the religious matter now being broadcast. However, still in our disinterested rôle of program critic, we think it should be clearly realized that there exists a great number of radio receiving set owners who can not conceivably be interested in this type of program. It is a matter



SIGNING THE "BOOK OF FRIENDSHIP" AT WRVA

Following a program of Indian songs, Chief Wa-hun-sun-a-Cook, Chief of Chiefs and Great Sachem of the Pamunkey tribe, spoke from WRVA. He is shown signing up Studio Director Elmer G. Hoelzle in the "Book of Friendship." Assisting in the honors are Pocahontas, the Chief's daughter, and Minnehaha, his wife

of simple equity that they also be shown some consideration.

Zeh Bouck, whose comments on radio and things in general appear in the *Sun* (New York) writes us on this topic. He evidently finds himself in this unchurchly section of the radio audience. His arguments are convincing, if caustic. He says in part:

"I should like to see something done in the way of reasonable religious broadcasting. There is entirely too much hymn singing, damning of lost souls, and evangelizing in our Sunday ether. In other words, we have entirely too much theology and not enough religion. Is there no broadcasting station with sufficient courage to devote an hour each week to a philosophical discourse on right living—considering morality from a scientific, not theological, point of view?"

"Aside from assisting Elmer Gantry in the preparation of sermons, Bob Ingersoll performed other useful functions during his life, one of which is summarized in his remark that, 'What we need is religion that will teach us how to live, not how to die.'

"While there are people who demand theology (the religion of golden streets, pearly gates, and seraphim), I see no really good reason why it should not be given to them. At the same time there are hundreds of thousands who are unable to reconcile Christian theology with their sense of criticism and scientific education.

"The type of religious broadcast that I suggest would be most welcome and helpful to this legion, which increases daily as the absurdities of fundamentalism—and even modernism—become more apparent in the light of a growing tendency to think clearly and independently."

Maintaining our position on the fence, we refuse to take sides either with the modernists, the fundamentalists, or with the skeptical group to which Mr. Bouck belongs. Each of these three groups should be given adequate attention, and service, in proportion to the numbers. Certainly under present conditions the fundamentalists are getting a disproportionately large share of the Sunday broadcasting time. This is well and good for the fundamentalists. For the others who chance to listen-in on Sundays it is no good at all. Why? Because they don't listen to it.

It seems absurd to bring out this point, which is so plainly evident. But it would seem to be a fact that is not clearly realized by the religious broadcasters. Or perhaps they realize it and ignore it. If so, we do not see how they can conscientiously ignore it—and they are conscientious folk. The worthiness of the final aims of an evangelical fundamentalist preacher might be readily agreed to by both the other factions in the radio audience. Yet neither of these factions would lend an ear to this same preacher's radio sermons. The reason is plain enough—they can not understand the language he is speaking. You

might protest until blue in the face that they *should* understand the language he is speaking, but that will in no way alter the practical fact that they don't.

So it seems to us that the radio station which books its Sunday solidly with sermons of this type is discriminating unfairly, and deliberately closing the gates of salvation, or denying the formula for right living, or—call it what you will, to a vast section of its regular listeners.

If a radio station owner sincerely and genuinely assumes a certain satisfaction for his part



JEROME DAMONTE, AT KGO

This artist is heard regularly on the luncheon concert program over this station on Mondays, Wednesdays, and Fridays. He is a member of the Novelty Trio

in conveying words of wisdom to thousands of souls, he must, if he be truly sincere and genuine, also assume the burden of his crime of omission in denying these same messages to half his clientele.

If he feels duty bound to turn over his facilities to such orthodox preachers as ask his service, he is by that same sense of duty, bound, as a purveyor of public service, to turn over his facilities to such speakers as could conceivably reach the ignored half of his audience.

This does not mean that he must act in non-accordance with his principles. It is his own radio station and surely he should not be asked to use it for the dissemination of doctrines which he sincerely believes to be pernicious. But it is perfectly possible for him to be of service to the unbelieving section of his listeners without violating any of his own pet beliefs. There are no end of contemporary writers and scientists, sociologists and philosophers who, without recourse to religious dogma at all, come to precisely the

same fundamental conclusions concerning right and wrong human conduct as have the venerable and understanding doctors of the churches.

Let the radio station manager select from this group of thinkers the men who reach, in their own quaint fashion, conclusions compatible with his own. Let him invite, urge, coax, or even pay these gentlemen to give Sunday talks from his radio station. In other words, let him appeal to the non-conformist group of his listeners in a language which they can understand.

To put our point concretely: Suppose some contemporary psychologist, through long years of scientific research and observation of his fellow humans, has come to the conclusion, moral aspects disregarded, that it is unscientific, unreasonable, unprogressive, and otherwise subversive of happiness, for a man to tread the primrose path. . . . Given a present day radio preacher holding forth on the same theme; he approaches it in an entirely different, if equally valid, method. But his method is so antagonistic to certain listeners, such as our correspondent, that they either refuse to listen to him or discount his conclusion. These same individuals might have been easily reached by a talk by the aforementioned psychologist.

The way is quite clear; it remains only for some enterprising radio station to take it up.

At any rate something should be done, and shortly, to improve Sunday broadcasting. In such a low state is it at the present time that we will hazard the guess that half the receiving sets in the nation lie idle the whole day through.

How It Feels to Face a Microphone For the First Time

MANY articles have been written on this subject, but none has afforded us more amusement, or seemed to more accurately portray the situation, than that written by Francis Hackett, the Irish novelist, for the *Radio Times* (London). A few paragraphs culled from the midst of others equally droll:

" . . . In the studio there is perfect silence. You must begin. And for two instants you are struck by a dumb futility. How do you know that anyone is listening? This audience is a blank. It is inanimate. It cannot clap or boo or say 'Hear, hear.' For all you know, everyone has gone away to dinner and you are about to chatter to the void. This thick suspicion is so unbearable that you brace yourself to believe in something totally outside your experience.

"It is like a dive. In the way that a diver must say good-bye to his springboard and launch his body into the air, so must you pass from the sure footing of silence and launch into speech. With a rushing and breathless celerity you give your words to space, and what you are saying flicks by you unrecognized, like telegraph poles



MUSICIANS ON THE STAFF OF WSM, NASHVILLE

Edward Stockman, baritone; Mildred King, pianist; Vito Pellettieri, violinist and director of Vito's Radio Seven; Lillian Watt, soprano

from a train window. This is a strange confusion. You know you have actually begun to speak, but what exactly you are expressing, what the words are conveying, is not in your grasp. In the first moments you have more sensations than you can deal with. This plunge is headlong, dizzying, and obliterating. You have broken with the habit of a lifetime, have lost the earth. Whenever before you have spoken in public you have had your victims before you. They looked at you, you looked at them; they coughed if you bored them, and when they fell asleep you could enjoy their peaceful expression.

"After the first five minutes, what you want to say really takes possession of your mind, and you definitely want to communicate to these invisible listeners exactly what you have felt. As this conviction mounts, the act of speaking becomes more natural and more amusing. You are not courageous enough to look at the clock, which is glaring at you from the right, and you dare not glance away from the microphone lest it should turn its back on you.

"The dive is over; you are no longer gulping the water and gasping; you begin to time your strokes, to find a rhythm, to swim. And as you do this, the futility of your own ideas gradually becomes less apparent; you actually convince yourself that what you are saying is not so idiotic.

"Then the pleasure of speaking to invisible listeners begins to gain on you. Can they escape from you? You don't believe it. The disease which attacks all speakers seizes on you—verbal elephantiasis. Your words begin to swell. You feel you have a great deal more to say, and you turn away so that the ugly, sour-faced clock can no longer see you.

"Several athletic young men loom up at this point and make formidable gestures. You plead. They threaten. They drag you away."

British Listeners Want Lighter Broadcast Fare

THE business of operating a broadcasting monopoly, it would seem to us from our occasional reading of English periodicals, is no more of a sinecure than the operating of a competitive station in America. Complaints are continually visible in the British press concerning the manner in which the B. B. C. presents its programs. Most of the complaints seem to be to the effect that the B. B. C. is too highbrow and is taking advantage of its monopolistic position to "high hat" the common peepul.

The London *Daily Mail* conducted a ballot of the preferences of the listening public and received the astonishing number of 1,285,083 replies. A vote of this size, it seems to us, can be taken as a very adequate expression of the general opinion in Great Britain, and this is how it resulted:

SUBJECT	VOTES CAST
Variety and Concert Parties . . .	238,489
Light Orchestral Music . . .	179,153
Military Bands . . .	164,613
Dance Music . . .	134,027
Talk: Topical, Sport, and News . . .	114,571
Symphony Concerts . . .	78,781
Solos: Vocal and Instrumental . . .	72,658
Opera and Oratorio . . .	60,983
Outside Broadcasts . . .	51,755
Short Plays and Sketches . . .	49,857
Talk: Scientific and Informative . . .	30,919
Glees, Choruses, Sea Chanties . . .	30,445
Chamber Music . . .	27,467
Revue . . .	27,059
Long Plays . . .	17,576
Readings and Recitations . . .	2,717
Free votes not recorded . . .	4,013
	1,285,083

The tenor of the vote was, as can be seen: (1.) A vote for more fun. (2.) A vote for fewer features which need sustained attention. The British conclusions rather parallel those gained from the questionnaire run in this department. Our readers have an overwhelming preference for instrumental music and a comparative indifference to plays, scientific talks, readings, and so forth. If a comparison to our questionnaire, which resulted in only one-hundredth as many replies, were fair, we might argue that the American public has a more sophisticated taste in music, since serious music, as of symphony orchestras, topped the list in our readers' vote, but is relegated to sixth place in the British vote.

THUMB NAIL REVIEWS

KYW and the blue network—The Philco Hour making its initial bow. We were playing bridge at the time and so couldn't give it very close attention, but we doubt if, conditions being otherwise, we would have. It struck us as an awful hodge podge of every sort and variety of entertainment that could be jammed into sixty minutes.

WMAQ and the red network—Another new advertising hour, this time an orchestra spons-

ored by the Cadillac-La Salle automobile manufacturers. The orchestra was all right but oh the drivel that was plentifully interlarded! Long spiels such as "and now the beckoning roads and the sunny skies call us to the great outdoors and the next number will be in the spirit of the spring-time and of the motor car we are selling, the La Salle. Grieg's 'To Spring'."

WEAF (and network)—We listened to an Eveready Hour devoted to "musical hits of pre-radio days," a program we had looked forward to with greedy anticipation. Sadly, though, but few of the tunes we heard were other than those one might listen to on any dinner music program, from any broadcasting station, on any night. However, a poor Eveready hour these days is sufficiently rare to merit notice.

KDKA—"The Prisoner's Song"!!!

WABC—We accidentally happened upon wabc a while ago just as "An Evening at Tony Pastor's" had begun to unroll itself. "Tony Pastor's," so we gathered from a rather brief announcement, was a one-time music hall on 14th Street, New York City, and the radio audience of wabc was asked to imagine itself seated before the stage of the Hall in the year 1895. So efficacious were the efforts of those responsible for the staging of the program in the studio that we did



THE WHITNEY TRIO

A capable organization frequently heard through WMAQ, Chicago, of whose staff they are members. From left to right they are Noreen, Robert, and Grace Whitney, brother and sisters

not find it in the least difficult to imagine that we were present at "Tony's," actually enjoying the show on the stage. We got a great kick out of hearing such old timers as "Take Back Your Gold," "Everybody Works but Father," and "My Mother Was a Lady." And when the foreign gentleman got into difficulties trying to explain his act, in which his three lions were to leap through burning "hops" (recognize "hoops?"), we thought we'd die laughing. The only thing that was a bit overdone, we thought, was the incidental conversation of the onlookers, which too obviously was spoken right into the microphone, and was rather inane anyhow.

Microphone Miscellany

CAMOUFLAGE FOR RADIO ARTISTS

THE new studios of the National Broadcasting Company in its Fifth Avenue home now under construction will make use of every device of color and decoration as a psychological means of egging the performers on to their best efforts. Operatic and stage stars, for example, will face the microphone in a large studio, with a spotlight playing upon them. The rest of the room will be dimly lighted, with the microphone placed in shadow where the artist cannot discern it, and the vista which will open before the performer will present the effect of a large auditorium, with a silent audience waiting to applaud the broadcaster's efforts.

One studio has been designed to appeal to prominent men. The suggested effect is that of the Roman Forum! Columns appear in the background, and a scheme of Pompeian decoration will be produced by hidden lights. Another studio is designed to stimulate minds to which the mystic carries a great appeal. Here the impression will be that of a Gothic church, with alternate light and dark sections suggesting the arch and aisles of such an edifice. From a concealed point near the ceiling the pattern of a church window will be thrown on the floor in light. The performer whose cosmic urge is titillated to activity by the proximity of pinchbeck, will be ushered into a studio of the style Louis XIV. Gilt and pastel colors will be much in evidence and through a window the effect of looking into an elaborate garden will be produced. One of the smaller studios will be decorated to stimulate jazz performers. In this room the decoration scheme will be wildly futuristic with plenty of color in bizarre designs. Another studio, designed to appeal to serious minds will pass itself off as a library. And, lo and behold, the advance report from the NBC goes on to state that two small studios will be left unadorned for the use of experienced broadcasters who react strongly to the mere presence of the microphone and the knowledge that millions of radio listeners are hearing them, although the audience is an invisible one.

We might suggest that a swimming pool be provided for Channel conquerors to make their speeches from; that a bed room with a yawning brat be supplied for the Uncle Charlies; that a saw-dust covered bar room floor be installed for singers of sentimental ballads; that a street scene in Madrid be improvised for temperamental Spanish instructors; that a—oh well, and so forth! But we refrain from this obvious pose. Adverse as our reaction is to such frumpery, we suspect that the powers of the National Broadcasting Company like it no more than we do and ordered the gew-gaws with their tongue in their cheek. Further, we extend to them our sympathy, for full well we know that they will become aw-

fully sick of spending their working days amid pseudo Gothic cathedrals and Rococo drawing rooms. Besides, if we were pressed, we would admit that the psychology behind all this sham work seems to us sound enough. The interpretative, or recreative, artist is notoriously devoid of good taste and his reactions to, and demands of, his surroundings continue to old age to be very childlike. This is only natural since his art is not self contained but comes from the outside. Your composer can sit him down in the most barrenly furnished, drab, little attic room and emerge hours later with a sublimely beautiful musical composition tucked under his arm. Set an average performer to playing that same tune in that same unattractive chamber and he will very likely protest that the surroundings are too depressing for him to do his best work. To rekindle in himself the emotions which charged the composer, he needs the warming lights, the dim auditorium, the silent, waiting audience, and all the other inspiring adjuncts of the theater. Four walls and a microphone cannot be an adequate substitute. So we think he is justly entitled to all the illusory trappings the National Broadcasting Company is preparing for him. And we are thankful that radio is still non-visual!

UNIFORM WAVELENGTH FOR CHAIN FEATURES

KNOWING nothing ourself of the mechanical problems involved, and having heard none of the probable several valid objections to the plan, we shall not comment on the contention of C. B. Smith of WBBM in his open letter to the Federal Radio Commission that the broadcasting of all chain stations on a uniform wavelength would be more convenient for the listener. He says:

The chain stations since the first of the year have done much to raise the standard of air entertainment in the United States. They should be highly commended. Nevertheless I do not believe this is sufficient reason to allow them to take up several air channels for these programs. My thought in this case, therefore, is that you might well give to each chain now in existence or which may be organized, a certain air channel. When a broadcast is given by the chain over several stations, each station should be compelled to change its wavelength to the wavelength of the chain's key station.

Assuming that the key station of a chain was located in Chicago and that its channel was 400 meters, when there is to be a broadcast over this chain every station involved should change its wavelength to 400 meters. As it is now, the same program from a chain station may be heard at many points on the dial of a receiving set.

This would in no way interfere with the chain broadcasts, but it would permit of more programs. It would in fact simplify matters for the listeners. For instance if the channel of the XYZ Chain was 430 meters, the listeners would always know just where to pick up the programs from that chain.

Communications

SIR:

I am a BCL of five years experience. I long ago got over the notion that I owe anything to the broadcasting stations, but once in a while when the announcer says they have made some change in the station and desire reports on reception I still write a report. But I think I am through. You send a report, date, time, set, audibility, R2., etc., and in due course receive a circular letter beginning, "We are glad you enjoy our program." The chances are that you were listening on the phones, late at night when you

should be asleep, and that the program came in bits mixed up with other stations, static, etc. The rest of the letter tells you that their garden seeds, night club, etc., is as good as their station and will you send them an order or come in and spend something.

The more enterprising put you on their mailing list and there is that much more mail to put in the waste basket. I have reached a state of mind where I am inclined to regard requests for reports on reception—as distinguished from direct requests for appesauce—as just another way of asking for the same thing.

Of course if WEAJ asks for reports when they open up at Bellmore I'll send one, but the average station, even if they do boast a thousand watts, can get its reports elsewhere.

Yours for more sleep and less stamps,
BEECHER OGDEN,
PLEASANTVILLE, New York.

SIR:

I admit that I think enough of RADIO BROADCAST to read it carefully every month, but if I ever secretly entertained an ambition to become an announcer, your editorial in the January issue ought to be an antidote. If everybody is as hard on them as you are, I do not envy them the job. Even at that, I bet you were just sore because you could not grab a gun and go after the ducks that woc gave the whereabouts of. And if WSBT asked everybody who "could do something" to drop in at their studio, is that such a serious offence? Did you ever try to get up a program without Atwater Kent's money to do it with?

"Next we will play for you—" Well, who are they playing for anyway? "You" takes in quite a few, you know. And then comes the fellow who wants the announcer to say: "Sit by!" It never occurred to me to stand up when the announcer says: "Stand by." I just turn the dials.

The only time an announcer almost frightened me was when he boldly stated that he was going to "Sign off the air." I had a sort of choking sensation as I pictured him shutting off the oxygen, but we lived through, and found the air clearer after he was "off," because he took with him some of the most miserable jazz I ever heard.

Just let them go ahead and read wires and dedicate, and "play for you," just so they play. But, please shed a tear for us out here who are expected to listen for hours at a fiend, who is doing his "durdnest" to sell automobile tires, plants, batteries, shrubbery, etc., and, as I write, on a stolen wavelength, too.

JAMES NEWBURGH,
SIOUX CITY, Iowa.

SIR:

Broadcasters are rather neglecting their country audience, as well as many of the worker class of their city audiences, by listing all their best programs at too late an hour. Even 9 P. M. is too late an hour for many of their most interested listeners, such as farmers, mechanics, the aged, etc. Of course these people do not write letters very freely, although they are most appreciative of good programs.

H. T. DEMAREST,
WARWICK, New York.

SIR:

Too much is said against Henry Field and Earl May stations, KFNF and KMA. Both are clean and satisfy our Iowa farm homes. They are a temperance people and we need more like them.

MRS. W. W. W.,
ESTHERVILLE, Iowa.

A Combined Push-Pull Power Amplifier and Socket B Device

Glow Tube Used to Maintain Constant Voltage and Prevent "Motor Boating"

Provision Is Made to Include Extra Audio Stage for Electrical Phonograph Pick-up

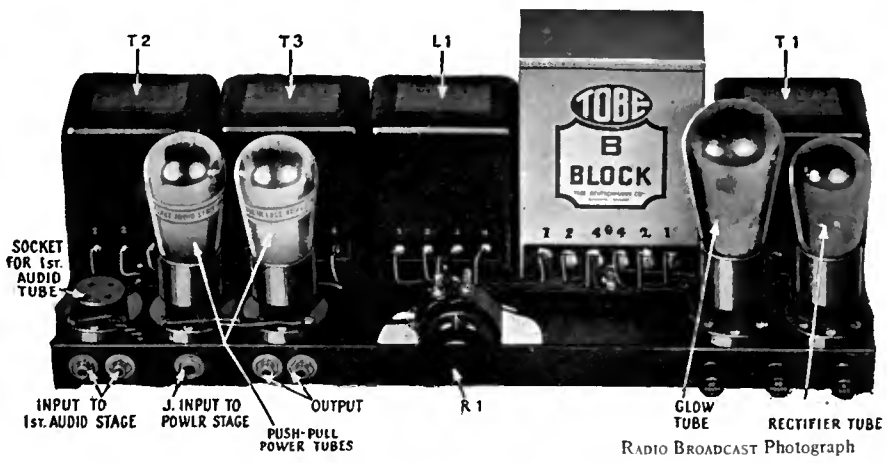

WITH THE CASE REMOVED
The parts are lettered to coincide with Fig. 2

By THE LABORATORY STAFF

IN THE May RADIO BROADCAST was described by Howard E. Rhodes an interesting power supply outfit designed by McMurdo Silver. This unit, shown here in Fig. 1, employed a full-wave rectifier, such as the UX-213 (CX-313) with the Clough filtering system, and delivered sufficient voltage for the operation of a 171 type tube in the final power stage in a receiver. Mr. Silver's unit, however, differed from others described recently in that it used the UX-874 (CX-374) glow tube to maintain the 90-volt tap at a constant voltage even though the current drain from that tap—and from the detector or 45-volt tap—varied through a wide range. The immediate effect of the glow tube is to decrease the apparent terminal impedance of the plate supply device so that "motor boating" trouble, experienced with resistance or impedance amplifiers when operated from socket power devices, is eliminated.

The photographs and Fig. 2 of the present article represent basically this same B supply device but with the addition of the necessary transformers to make up a power amplifier. Mr. Silver in this combination amplifier-B supply device has used a push-pull amplifier in which may be used either 112 or 171 type tubes.

If the broadcast listener who constructs this combination unit (all he really has to do is to wire it up) is near local high-quality broadcast stations of average power, he will use 171 tubes. If, on the other hand, he is some distance from powerful stations, 112 type tubes will produce more volume owing to their greater amplification factor, although their handling capacity is more limited.

The complete equipment is housed in a metal case that not only protects the tubes from damage

but lends a finished appearance to the unit. Space is provided for an extra socket so that, with a resistance coupling unit which may be installed below the baseboard, a two-stage amplifier results, which can be worked out of a detector. It will be necessary to use batteries for the filament and C bias of this first-stage audio tube, and since it is only to be used as a voltage amplifier, a 199 can be utilized with results almost comparable to a storage battery tube. Three dry cells may be used, two for filament and one for C bias; they will last long enough to provide, for all practical purposes, an extremely economical amplifier.

The development of the combination B supply device and power amplifier started from two separate angles, *i.e.*, the demand for high-quality audio reproduction which necessitated the use of a power tube, and the need for a powerful B supply to furnish power for this last stage audio tube. At the time the combination unit was developed, many existing receiver installations were unable to supply the necessary voltage for the operation of a power tube inserted in the last audio stage, while the audio coupling devices found in many receivers of that period were poor, to say the least. The combined power amplifier stage and B supply was an important development then, not only from the standpoint of qual-

ity reproduction, but also from the standpoint of simplicity.

The power-supply device described here is capable of furnishing well rectified and filtered power to the receiver proper and to the power amplifier. This power is sufficient to take care of the demands of a good amplifier, that is, one which amplifies the lowest notes which are now being transmitted, and this power is furnished by a device with as low a terminal impedance as possible to prevent "motor boating" and kindred effects. This feature is accomplished by the use of the glow tube (UX-874 or CX-374). The amplifier has a good frequency characteristic, and secondly, it is capable of handling considerable input voltages. It is also efficient; that is, with a given input voltage, it will deliver to the loud speaker as great an undistorted power as possible.

PUSH-PULL AMPLIFICATION

THE push-pull form of amplification is employed in this power amplifier, and it has several advantages. In the *General Radio Experimenter* for May, 1927, Mr. C. T. Burke claims for the push-pull circuit "greater undistorted output than is possible with two tubes in parallel or a single tube. Even harmonics are eliminated. As most of the harmonics introduced by tube overloading are even, this permits operation of the tubes at heavier loads than is possible with the usual system. Another advantage is the elimination of d.c. magnetization of the output core as the direct current flows in opposite directions from the two tubes."

Considering several amplifiers each worked into its own impedance the power output may be found by multiplying the

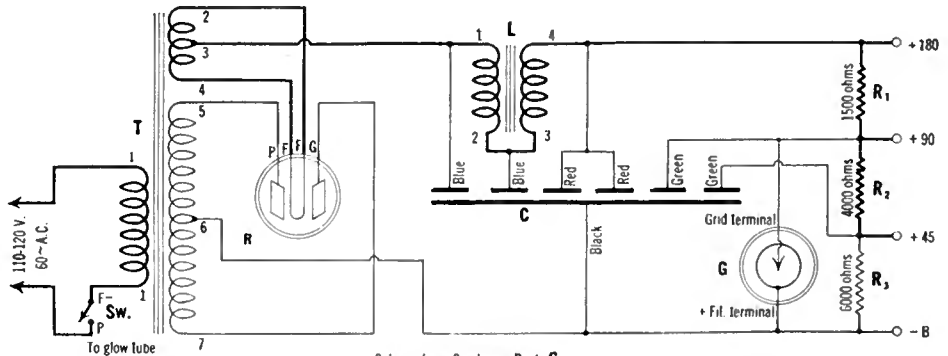

Color code on Condenser Bank, C
Blue = 2 mfd. Green = 1 mfd.
Red = 4 mfd. Black = common

FIG. 1

factors below by the square of the input r.m.s. volts:

SINGLE	SINGLE	SINGLE	PARALLEL OR PUSH-PULL:
171	112	210	171
1125	3.34	3.04	2.25
			112
			6.7

The maximum power in milliwatts obtainable, however, under the condition of maximum allowable plate and grid voltages, is as follows:

SINGLE	SINGLE	SINGLE	PARALLEL OR PUSH-PULL:
171	112	210	171
920	184	1860	1840
			368

There is another consideration. It has been demonstrated mathematically that the greatest undistorted power output will be delivered when the load impedance is double that of the amplifier output. It must be remembered too that the above figures are for a resistance load and that a single 171 will deliver its greatest power to a loud speaker whose impedance at some frequency is equal to about 2000 ohms. The parallel arrangement will do the same at a frequency where the impedance is 1000 ohms, while the push-pull amplifier "matches" at approximately 4000 ohms. The Silver output transformer is designed to match the average cone type loud speaker to the amplifier at approximately 30 cycles. As Mr. Burke points out, greater input voltages can be placed on a push-pull amplifier without distortion due to overloading becoming evident or objectionable. Thus this type of amplification which has been neglected since the advent of high-quality transformers, once more is made available for the home constructor, this time in an attractive form and with excellent electrical characteristics. The input transformer is similar in frequency characteristics to the S-M 220.

Some trouble may be had with the amplifier singing when 112 tubes are used—a difficulty that push-pull amplifiers of good construction frequently get into. The remedy is simple: Place a 0.0001-to 0.0004-mfd. fixed condenser across one-half of the input push-pull secondary windings, which will unbalance the amplifier enough at high frequencies to prevent singing.

The circuit diagram of the complete power amplifier and plate power supply is shown in an accompanying diagram, Fig. 2. In this case a gaseous rectifier such as the Raytheon BH or the

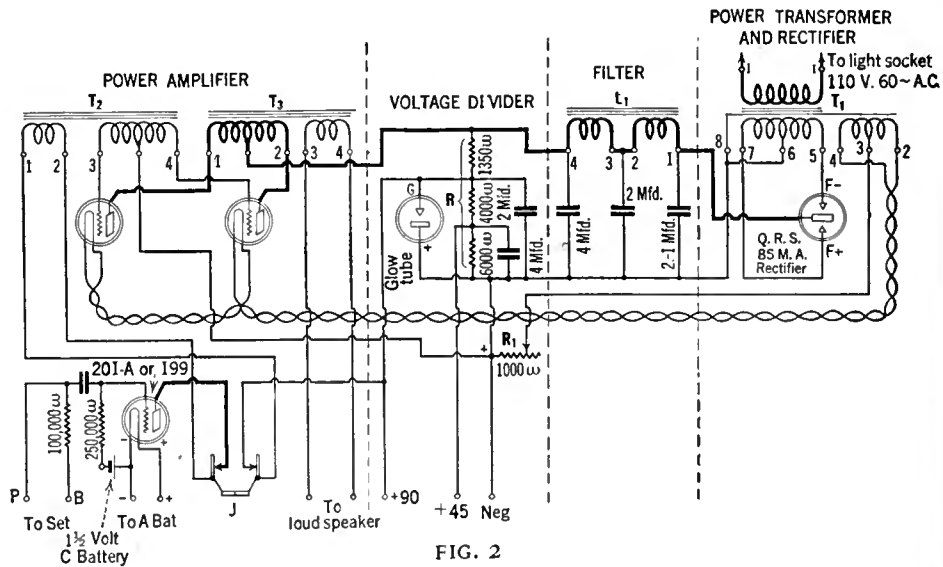

QRS 85-milliamper tube is used instead of the thermionic rectifier that was used in the original device described in May. The filament winding on the S-M 329 transformer is used to light the filaments of the push-pull amplifier tubes. Connections are also shown for the resistance input

battery, and some arrangement made whereby turning on the set turns on this tube. For example, its filament can be placed in parallel with that of any of the receiver's tubes, and with the proper ballast or rheostat so that both tubes get the proper current, automatic control over all filaments is secured.

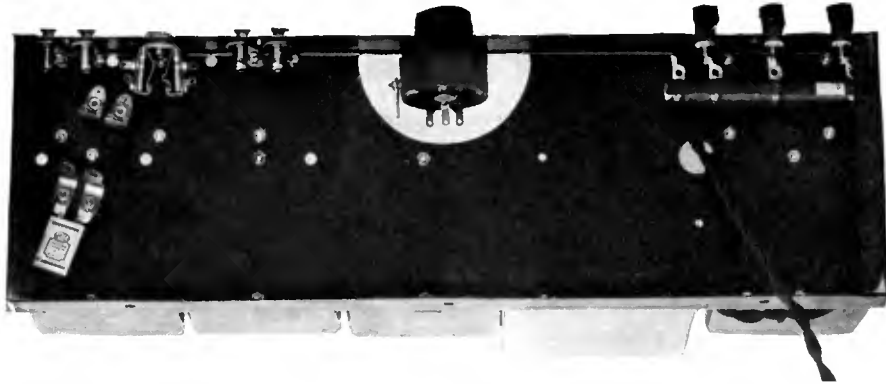

UNDERNEATH THE UNIT

The additional socket provided in the assembly makes it possible to use this combination amplifier-B supply device with a phonograph pick-up. Greater signal strength will be obtained by connecting the pick-up to the first tube by means of a good audio transformer. In the Laboratory several of the well-known pick-up devices were used with success.

The following is a list of parts used in the amplifier-B supply unit described here:

T ₁ —S-M No. 329 Power Transformer.	\$ 6.00
T ₂ —S-M No. 230 Push-Pull Input Transformer	10.00
T ₃ —S-M No. 231 Push-Pull Output Transformer	10.00
L ₁ —S-M No. 331 Unichoke.	6.00
Tobe No. 660 Condenser Block (Containing Two 4-Mfd., Two 1-Mfd., and Two 2-Mfd. Condensers)	12.00
R—Ward-Leonard S-11,350 Tapped Resistance or S-M No. 655	2.50
R ₁ —Frost No. 834, 1000-Ohm Potentiometer	1.00
Four S-M No. 511 Tube Sockets	2.00
Four Frost No. 253 Tip Jacks	.60
Van Doorn No. 661 Steel Chassis and Cabinet with Hardware	6.00
Three Eby Binding Posts (B Minus, Plus 45, Plus 90)	.45
Q.R.S. 85-Mil. Rectifier Tube	5.00
CX-374 or UX-874 Voltage Regulator Tube	5.50
Two 112 or 371 Type Amplifier Tubes	9.00
TOTAL	\$76.05

ADDITIONAL PARTS FOR FIRST AUDIO STAGE	
S-M No. 511 Tube Socket	.50
Lynch Double Resistor Mount	.50
Lynch $\frac{1}{2}$ -Megohm Resistor	.75
Lynch $\frac{1}{4}$ -Megohm Resistor	.50
Tinytobe 0.01-Mfd. Fixed Condenser	.55
Frost No. 951 Four-Contact, Double-Circuit Jack	.50
TOTAL	\$ 3.30

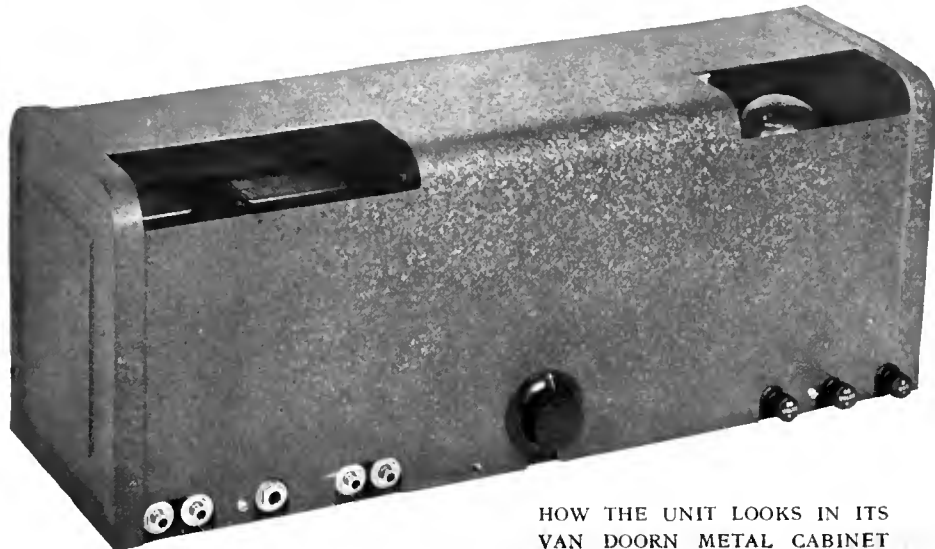

HOW THE UNIT LOOKS IN ITS VAN DOORN METAL CABINET

A Portable Long-Wave Receiver

A Description of the Receiver Built by the Laboratory for the American Geographical Society—Some of the Signals That May be Heard

By KEITH HENNEY

Director of the Laboratory



RADIO BROADCAST Photograph
THE FINISHED RECEIVER

This illustration clearly indicates how the aluminum sheets are arranged to divide the metal cabinet into compartments for batteries and phones, etc.

AMONG other noteworthy services due to radio is the increasing ease and accuracy with which navigators and explorers can determine their distance east or west from the Greenwich meridian. Time signals transmitted by wireless, which are used for such calculations, can be heard in practically all parts of the world with apparatus simple enough to be built by unskilled constructors, and light enough in weight to be carried, complete with batteries, on a man's back. The apparatus described and illustrated in this article is the result of several receivers constructed by RADIO BROADCAST Laboratory for explorers and for the American Geographical Society.

The receiver consists, in radio language, of a single-circuit long-wave set using honeycomb coils, and having two stages of audio amplification. The set first picks up and detects the signals, after which they are amplified sufficiently to be audible in a pair of headphones. Three dry-cell tubes (199 type), three A batteries, and two small B batteries (one is a spare) of 22.5 volts, are included in the metal case, together with antenna and ground wires, extra tubes, headphones, and simple tools.

The diagram of connections is shown in Fig. 1 and any one who has ever built or torn down a radio set will have no difficulty in constructing this simple receiver. Although the tubes are delicate, experience has shown that their life is quite long even when they must withstand severe shocks encountered in the field.

Several receivers of this general type have been built and placed in the hands of explorers in Brazil, Guatemala, and Venezuela. The first was placed in a Signal Corps telephone box having the approximate dimensions of four by eight by ten inches. The second was housed in a stout wooden box specially made and sufficiently large to accommodate the entire equipment. The third was placed in a metal tool box made by the Kennedy Manufacturing Company, with a tight fitting cover, and is perhaps the most satisfactory design. It is shown in the accompanying photographs. Complete with batteries, wire, and tools, it weighs about 22.5 pounds.

THE ANTENNA

THE antenna is very simple, consisting of a single wire from 50 to 100 feet long, and may be of any kind of wire, insulated or not. A simple manner of solving the antenna problem is to use a spool of rather fine wire so that many hundred feet may be included without adding much weight. Each antenna may be abandoned

in this case after signals have been received, since the spool will contain enough wire to last an expedition several weeks listening-in once each day. A one-pound spool of No. 28 bare copper wire is about 2000 feet in length. Such a spool therefore, would provide sufficient wire for twenty antennas of 100 feet in length.

Some success has been had using loops in place of external antennas. They are useful in thick country where a long external wire would be difficult to erect. Signals, however, are not so loud with a loop although the directional effect is useful in avoiding interference and increasing the signal-to-static ratio.

A wire about 50 feet long, attached to a metal stake or plate and thrown into a creek or driven into moist earth, constitutes the ground connection. In dry or rocky territory the wire may be laid on the ground with practically the same results.

The accompanying diagrams and photographs give in sufficient detail the actual construction of this receiver. The Kennedy metal cabinet is divided into three compartments by means of two aluminum sheets 8" x 7" x 1/16", and these are held in place by means of 3/4" angle brass. The three 1 1/2-volt A batteries are placed in the right-hand end metal compartment. An extra set of A batteries is usually carried with the exploring party, ready to slip into the receiver box. In tropical climates, and with reasonable care in handling the tubes, it should be possible to receive time signals daily for a period of about six months without requiring new batteries or tubes. All connections should be rigidly made of well insulated wire, and should be well soldered.

The receiver is placed into operation by opening the cover, making the ground connection,

throwing a length of wire over a tree limb, or over any other elevation, plugging in the ear phones, and turning on the current to the tubes. At once signals should be received, since there are many high-powered long-wavelength stations pounding away at all hours of the day or night with sufficient intensity to be heard anywhere in the world.

In the United States the largest station sending time signals is Annapolis, a Navy station, whose call is NSS, wavelength 17,130 meters (17.6 kc.). With a 1500-turn honeycomb coil and a 0.001-mfd. tuning condenser, signals from this station will be heard from about 40 to 50 degrees on the condenser dial. About the time the signals are to be transmitted, this station may be heard emitting a continuous note while others will be transmitting in irregular dots and dashes. Time signals from this station—and from all other American stations—consist of a series of dots, and no difficulty should be experienced in distinguishing them from the more or less irregular sending of the other stations which will be heard at the same time. Adjusting the tuning condenser will enable the operator to find a point where NSS, or whatever station is being heard, is less bothered by interfering stations.

Time signals from NSS and from all United States stations consist of dots at every second from 11h. 55m. 00s. to 11h. 59m. 49s. and from 21h. 55m. 00s. to 21h. 59m. 49s., except at the 29th second of each minute and the last 5 seconds of each minute. The beginning of a dash at noon and at 22h. 00m. 00s. Standard Time, indicates the exact time. The lag constant for Annapolis time signals has been determined as 0.08 seconds.

Time signals transmitted from other stations are given in Table No. 1, and complete details of the transmission may be obtained from the stations themselves or from Radio Aids

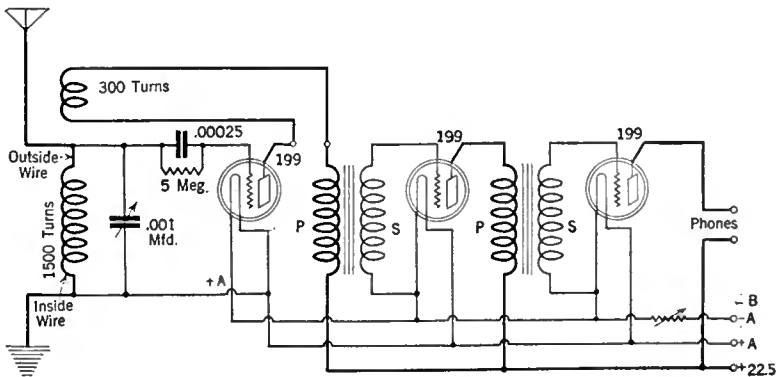

FIG. 1

to Navigation, published by the Hydrographic Office of the U. S. Navy, at 90 cents.

For those interested in learning the code, the receiver described here will be found to be very helpful. At all times of day or night, in any part of the world, signals may be heard, some very fast, others slow enough for the novice to copy. Some of it is in secret code, long words with absolutely no meaning or context, admittedly the best material for code practice. Other signals are in readable English and often the words are repeated twice. In the Laboratory, press has been received from LY in France and GBT in England.

Technically, the method of receiving used here is very inefficient. The receiver employs the beat note system of reception. That is, the detector tube oscillates, and the signals actually heard in the headphones are the beat notes caused by heterodyning of the incoming signals with those generated in the receiver. In other words, the receiver is actually detuned from the incoming frequency. For example, suppose we are listening to a station transmitting on 20,000 meters (15,000 cycles). Our ears and our headphones are most sensitive to notes of the order of 1000 cycles, so we detune our detector circuit to, say, 16,000 cycles, so that the desirable 1000-cycle beat note will result (the frequency of that beat note is equal to the difference of the two heterodyning frequencies, 16,000 - 15,000 kc. in this case. At the same time suppose a station to be transmitting on 16,000 meters (18,750 cycles), this will produce a second beat note in our headphones of 2750 cycles, so this latter station too may be heard.

When the detector is tuned to the exact frequency of the incoming signals, we shall hear nothing, for there is no beat note being produced.

Code listeners in the United States should be able to hear the stations listed in Table No. 2 and, under good conditions, many others in foreign countries. It is interesting to note that all of the stations in table No. 2 are operating in a frequency band only 8.2 kilocycles wide, a condition that seems appalling when one considers the wide bands available for broadcast or amateur work. In commercial receiving stations signals are picked up on special antennas which have considerable directive effect, after which they are filtered through circuits which pass a band only 200 cycles wide. They are then amplified until strong enough to operate relays which print the dots and dashes on tape. The receiving operator can copy either by sound or by watching the tape, or both.

An approximate calibration of a receiver similar to that shown in the photographs is given in Fig. 2. Owing to the broad tuning, a given

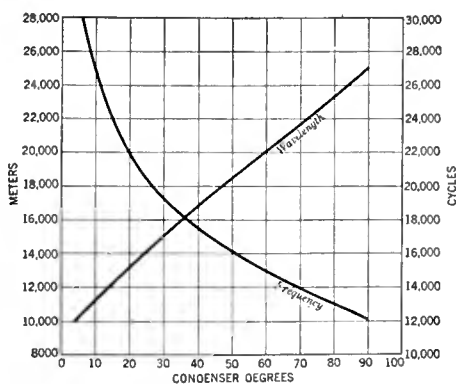

FIG. 2

station may be heard over rather a wide condenser variation, and several stations may be heard at the same time, as described above.

APPARATUS NECESSARY

The list of apparatus gives the equipment that went into the metal encased receiver built for the American Geographical Society. The problem is one of limiting the space and

the coils must be mounted so that they will not be close or parallel to the metal wall. The tickler coil should be placed between the secondary coil and the iron, and if the detector does not at first oscillate, the tickler coil connections should be reversed. Some transformers may require a bypass condenser across the primary to insure good detector oscillations. The hedgehog did not require such a condenser but in case it is needed it should be of about 0.006 mfd

- 3 Benjamin Sockets \$1.80
- 2 Hedgehog Transformers 7.00
- 1 0.001 Mfd. General Radio Condenser and Dial 7.50
- 1 1500-Turn Honeycomb Coil 3.20
- 1 300-Turn Honeycomb Coil 1.05
- 1 Baseboard 8" x 7" x 1 3/8"10
- 1 Kennedy Metal Cabinet, 16"x8"x9" 3.25
- 1 22 1/2-Volt B Battery 1.75
- 3 1 1/2-Volt Dry Cells 1.20
- 1 Pair Phones 5.00
- 1 20-Ohm Carter Combined Rheostat and Switch 1.00
- 4 XL Binding Posts60
- 1 8" x 6" Panel 1.00
- 3 UX-109 Tubes 5.25
- 1 Grid Condenser50
- 1 Grid Leak50
- 4 Pieces 3/4" Angle Brass 7" Long30
- 2 Pieces Aluminum 8" x 7" x 1/8"25
- Total \$41.25**

STATION	CALL LETTERS	WAVE-LENGTH	FREQUENCY
Marion, Massachusetts	WSO	11620	25800
Marion, Massachusetts	WRQ	13505	22205
Bolinas, California	KDU	13100	22890
Rocky Point, New York	WQK	16465	18250
Rocky Point, New York	WQL	17500	17130
Rocky Point, New York	WSS	16120	18600
Annapolis, Maryland	NSS	17030	17600
Tuckerton, New Jersey	WCI	16700	17950
Tuckerton, New Jersey	WGC	15900	18860

TABLE NO. 2

weight requirements. Unmounted transformers made by Modern, of Toledo, and the hedgehog type transformer of the Premier Electric Company, of Chicago, have been successfully used. The Kennedy tool box is made of sheet iron and

The Kennedy metal cabinet referred to in the above list of parts is manufactured by the Kennedy Manufacturing Company, Van Wert, Ohio.

Using the two coils specified in the above list of parts, the receiver described will have a wavelength range of from about 10,000 to 25,000 meters (30 to 12 kilocycles). To cover other wavelengths, coils with a different number of turns than those specified should be used. The following list gives the various standard coils which should be used in the antenna circuit with a 0.001-mfd. tuning condenser together with the wavelengths they cover: 25 turns, 120-355 meters; 35 turns, 160 to 480 meters; 50 turns, 220-690 meters; 75 turns, 340-1020 meters; 100 turns, 430-1330 meters; 150 turns, 680-2060 meters; 200 turns, 900-2700 meters; 250, 1100-3410 meters; 300 1400-4120 meters; 400 turns, 1800-5500 meters; 500 turns, 2300-7000 meters; 600 turns, 2800-8200 meters; 750 turns, 3500-10400 meters; 1000 turns, 4700-13800 meters; 1250 turns, 6000-18000 meters.

The tickler coil should have from a third to half as many turns as the coil to which it is coupled.

The arrangement of parts may be clearly discerned from this behind-the-panel view

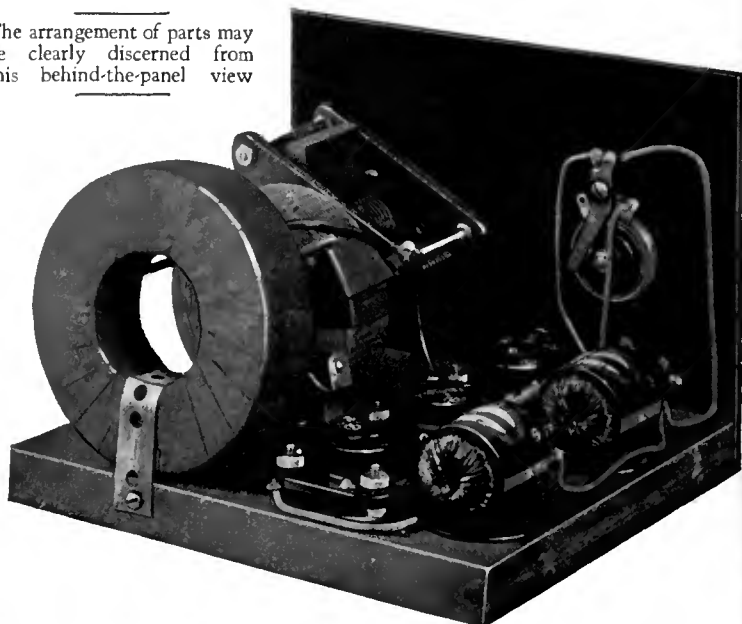

RADIO BROADCAST Photograph

COUNTRY	STATION	CALL	G. C. T.			WAVE LENGTH (Meters)	DIAL SETTING (Approx.)
			h.	m.	s.		
United States	Annapolis	NSS	17	00	00	17130	42
			3	00	00	17130	42
	San Diego	NPL	20	06	00	9801	0
Panama	Colon	NBA	10	00	00	6663	—
			18	00	00	6663	—
Hawaiian Islands	Pearl Harbor	NPM	00	00	00	11490	15
France	Bordeaux	LY	8	00	00	23400	80
	Lyons	YN	9	00	00	15500	35
Germany	Nauen	POZ	11	58	10	18050	50
			23	58	10	18050	50
Russia	Petrograd	RET	19	00	00	7100	—
	Moscow	RAI	21	00	00	7480	—
Eritrea	Massawa	ICX	10	00	00	11150	—
Java	Malabar	PKX	1	00	00	7700	—

Note: G. C. T. is an abbreviation for Greenwich Common Time. It is five hours ahead of Eastern Standard (75th meridian) Time. Thus 12 noon in New York is 17h. 00m. 00s. in G. C. T., which starts at midnight with 00h. 00m. 00s. and runs to 24h. 00m. 00s. Thus 8h. 00m. 00s. G. C. T., when LY sends time signals, is 3 a. m. E. S. T.

TABLE NO. 1

AS THE BROADCASTER SEES IT

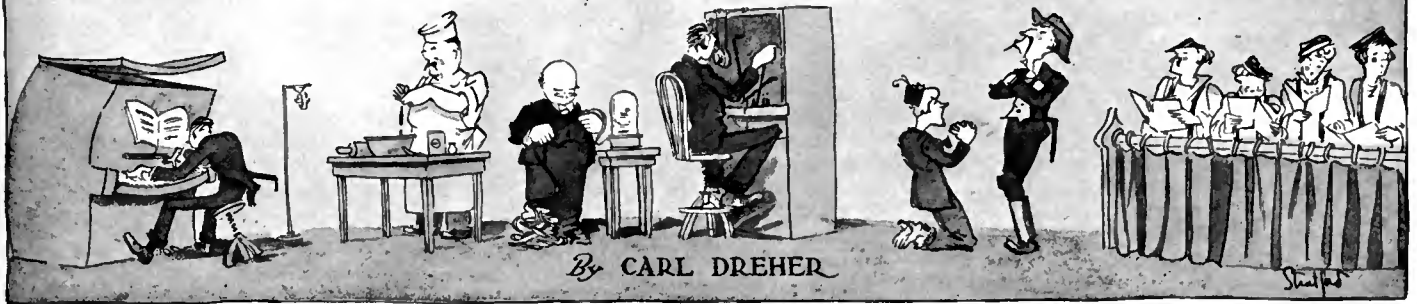

Drawings by Franklyn F. Stratford

The Place of Television in the Progress of Science

ONE of the New York newspapers, commenting editorially on the recent television demonstration by the American Telephone and Telegraph Company, points out that there is no immediate commercial application for this latest marvel of technology, in view of the elaborate equipment and skilled attendance required. But, the writer adds, other inventions, such as the electric light, the phonograph, the airplane, and radio, have appeared with the same limitations, and he predicts that the televisior will undergo the same process of simplification and adaptation for everyday use. "Meanwhile," he speculates, "the invention may function in small but important fields. It would seem to make the identification of a kidnapped child or a murderer, found in some distant city, an easy matter."

The example is poorly chosen. For such purposes of identification the already more or less perfected and commercialized transmission of photographs would seem a much superior means. It takes only a fraction of an hour to take the photograph and reproduce it at a distance by wire or radio, and the results, at this stage of the game, are apt to be better. The expense should also be less. Television is inherently more complicated than telephotography, just as taking moving pictures is necessarily more difficult than snapping a still photograph, although with sufficient development both processes may be brought within the layman's reach. The editorial, however, suggests the need of thought on the subject of what rôles may best be played in the drama of modern life by such scientific applications as television, telephony, the phonograph, talking movies, aural broadcasting, and allied inventions.

In Table No. 1 below, the characteristics of the principal sense- and intelligence-reproducing inventions in this group are given:

TABLE No. 1

	SOUND	Nature of Utility	LIGHT
Phonograph	Permanent record	Photograph (static)	Motion Picture (kinetic)
Telephone	Rapid reproduction at a distance	Television	

Sight and hearing are the two principal senses

of the higher animals. The other senses are quite limited in range and contribute less to the picture of the universe which man, especially, must try to construct for the purposes of his life. Accordingly, inventions in communication specialize in these two senses. We find, on this basis, two inventions—the phonograph and the motion picture—which permit the recording of sounds and sights, respectively, and their reproduction after a lapse of time. It should be noted that the



"THE WAX DISCS MAY BE CARRIED TO DISTANT POINTS"

motion picture, not the still photograph, is the logical counterpart of the phonograph. The motion picture gives a kinetic visual reproduction, corresponding to the kinetic aural reproduction of the phonograph. In music or speech one sound follows another, just as moving bodies are seen in one position following another in our visual perception of the external world. The motion picture is made possible, however, only through the physiological lag of the eye—the

persistence of vision phenomenon—which enables us to merge a rapid succession of still pictures into apparently continuous motion.

Both the motion picture and the phonograph may be regarded as part of man's efforts to overcome the transitoriness of life. As Heraclitus pointed out some 3200 years ago, the most noticeable characteristic of the universe is that it exists in a state of constant flux. This means that many interesting or beautiful things will happen while some people are not present and must be reproduced artificially for those persons if they are to enjoy them. Even those who were present at the original occurrence in order to re-experience their sensations must have recourse to such machines as the motion picture camera-projector and the phonograph recorder-reproducer. Being machines, such devices are capable of mass reproduction of prototypes. In this way, John Barrymore and Caruso, alive and dead, are spread over the earth. In other words, by means of motion pictures and talking machines we try not only to protect ourselves against the fleeting nature of desirable events but also to multiply those events artificially by making them take place elsewhere than at the original location. Caruso and Barrymore cannot be transported to all the places where their presence is desired, but the wax discs and rolls of celluloid which are capable of reproducing their remarkable qualities may be carried to distant points very readily, and not less readily when the artists, having died, no longer emit beautiful tones nor present a pleasing appearance to the eye. Essentially, therefore, motion pictures, phonographs, and their synthesis, the talking motion picture, are means of, first, resisting the passage of time, and, secondly, overcoming the spatial and energetic

limitations of certain special human beings whose performances are of great interest to their fellows. By the refinement of machinery these aims are being accomplished with a constantly closer approach to perfection as regards sight and hearing, the two essential senses in the particular relationships involved.

As the phonograph and motion picture apparatus are basically systems to overcome the passage of time, so the telephone and televisior

have the aim of overcoming the obstacle of intervening distance in the fields of sound and light respectively. By means of the telephone, sounds are transmitted practically instantaneously over distances which would otherwise render them inaudible, and now the television apparatus performs the same service for the sense of sight. The American Telephone and Telegraph Company's demonstration was really a combination of two inventions—the telephone and the televisor, in the same way that the talking motion picture combines the phonograph and the motion picture, but everyone is so used to the telephone that this aspect of the situation has been overlooked. Another explanation for this lies in the fact that voice and appearance are automatically linked in the television-telephone subjects, without the necessity for synchronization of sound and light vibrations which we must effect in the picture-phonograph combination. But, leaving this point to return to the main thread of our analysis, we note that by means of the telephone and the televisor we project ourselves, sensorially, through space; with the phonograph and motion picture we project ourselves backward through time.

The telephone and the televisor, like all the inventions of the "tele" group, utilize electric waves. This is because such waves, traversing space at a speed of 186,000 miles per second, cover terrestrial distances instantaneously as far as most activities of human beings are concerned. Even when, as in the telephoto process, the complete transmission takes an appreciable fraction of an hour, this is merely because the breaking up and re-integration of the picture, optically, takes time. In Table No. II the principal inventions of the "tele" group are summarized, with the dates, not of initial invention, which are controversial and difficult to determine in some cases, but of practical demonstration, when it became evident that the problem was well on the way to complete solution:

TABLE No. II

DATE	INVENTION	NATURE OF UTILITY
1835	Telegraph	Transmission of symbols
1876	Telephone	" " sounds
1922	Telephoto	" " sights (static)
1927	Television	" " " (kinetic)

The inventions of the "permanent record" group all use the device of impressing a performance which, being functional, passes with time, on some material substance which, to a degree, is independent of time and may also be multiplied indefinitely, each multiplication adding a large number of possible reproductions of the original event. The invention of printing is one of the early applications of this principle. A man has ideas, which are functional in their nature. By printing them he transmutes the ideas into the material form of symbols on paper, which may be read and reproduced as ideas by another man reading the symbols perhaps centuries later. The author projects himself functionally into the future, the reader into the past, by this physical device. The recent inventions of this group, which have to do with sight and hearing, are summarized below:

TABLE No. III

DATE	INVENTION	NATURE OF UTILITY
1839	Photograph	Recording and later reproduction of sights (static)
1877	Phonograph	Recording and later reproduction of sounds
1893	Motion picture	Recording and later reproduction of sights (kinetic)
1926	Talking motion pictures	Recording and later reproduction of sights and sounds

From Tables No. II and III some of the relationships between these inventions may be traced. The telegraph, invented in 1835, utilized the crudest possible form of modulation of electric waves—simply starting and stopping a constant

amplitude current according to a code. A little later the chemical fixation of the images in the camera obscura was accomplished. The telephone, following the telegraph in 1876 after an interval of 41 years, required a much more subtle modulation of the electric currents, and this has been further complicated in telephotography and television. The phonograph was invented almost at the same time as the telephone. The motion picture, following the still photograph after 54 years, is merely an ingenious elaboration of the latter. Talking movies, as has been pointed out before, are produced by combining the phonograph and cinematograph. In the same way the telephoto process may be considered a synthesis of photography and the principles of the telegraph and telephone. Television is derived from the two latter, the telephoto systems, and the motion picture art. The fundamental inventions, in this sense, are the telegraph, the camera, and the phonograph. The others are elaborations and cross-breedings. Taking them all in all, in a space of 100 years (1835-1935), allowing 8 more years for the development of television, the effective rapid transmission of symbols, sounds, and sights will have been accomplished; and the art of recording and reproducing at a later time sounds and sights, separately and in combination, will have been, for all practical purposes, perfected.

It will be noted that nothing has been said about broadcasting and wireless telegraphy in this discussion. That is because, coming down to fundamentals, radio is only a part of telegraphy and telephony. In wire telephony we modulate a direct current at audio frequency and send it directly along a wire. In broadcasting we superimpose the same variations on a radio-frequency current, and transmit them from an antenna in all directions through space. In each case our object is to reproduce sounds at a distance. One form happens to be suited for point-to-point communication between individuals, while the other is suited for one individual addressing an audience, or for the distribution of a single performance to a large number of individuals separated in space, but the difference is a secondary one. As in all telephony, the sound-emitters and sound-receivers are separated in space, but not in time. This will result in profound differences in the social application of the arts in question, but the metaphysics remain identical.

All these inventions are, in the last analysis, means by which human beings secure agreeable or necessary sensations, in the absence or because of the unavailability of the original sources of those sensations, owing to the movement of time and the non-movement of space. When agreeable sensations are involved we are dealing with entertainment; when the sensations are necessary, rather than merely pleasant, we speak of utility. There is no sharp dividing line. Broadly, one sustains life; the other helps make it worth while. Let us hope that television will do both. For the present we shall be satisfied with this outline of the hundred-year era which it closes, and, seeing it against this background, we shall be less likely to go astray in the hazardous business of prophecy.

Concerning the specific applications of television among the other arts of communication we shall have more to say hereafter.

What the Broadcast Technician Should Read

OVER two years ago (in the April, 1925, RADIO BROADCAST) we printed a short bibliography for broadcast operators and engineers, consisting mainly of references to articles in the *Proceedings of the Institute of Radio En-*

gineers and the Journal of the American Institute of Electrical Engineers. Since then a considerable number of valuable contributions have been added to the literature, so that it now appears advisable to reprint the original list with the additions. This is also done in response to requests which we receive at intervals from readers interested in the technique of broadcasting or speech reproduction, and in need of help in selecting their reading matter. While this department is always ready to advise broadcasters with regard to the literature in this field, and to give individual attention to special problems, the present summary of available books and papers should serve the requirements of a majority of readers. The list is not confined to works on broadcasting as such, since to attempt to master the technique of broadcasting, without preparation in the general principles of radio communication and acoustics, is like trying to fence before one has learned how to hold a foil:

GOVERNMENT PUBLICATIONS

Obtainable from Superintendent of Documents, Government Printing Office, Washington, D. C.

<i>Principles Underlying Radio Communication</i> —Second Edition. (Radio Communication Pamphlet No. 40; Signal Corps, U. S. Army).	\$1.00
<i>Radio Instruments and Measurements</i> (Bureau of Standards Circular No. 74).	.60
<i>Telephone Service</i> (Bureau of Standards Circular No. 112).	.65
<i>Sources of Elementary Radio Information</i> (Bureau of Standards Circular No. 122).	.05
<i>Architectural Acoustics</i> (Bureau of Standards Circular No. 300)	.05

BOOKS

Morecroft: *Principles of Radio Communication.* John Wiley & Sons, Inc.
 Van Der Bijl: *The Thermionic Vacuum Tube.* McGraw Hill Book Co.
 Moullin: *Radio Frequency Measurements.* J. B. Lippincott Co.
 Johnson: *Transmission Circuits for Telephone Communication.* D. Van Nostrand Co.
 Miller: *Science of Musical Sounds.* Second Edition. Macmillan.
 Sabine: *Collected Papers on Acoustics.* Harvard University Press.

JOURNAL OF THE AMERICAN INSTITUTE OF ELECTRICAL ENGINEERS

Issues obtainable from American Institute of Electrical Engineers, 33 West 39th Street, New York.

Martin and Clark: "Use of Public Address Systems with Telephone Lines." April, 1923.
 Green and Maxfield: "Public Address System." April, 1923.
 Arnold and Espenschied: "Transatlantic Radio Telephony." August, 1923.
 Osborne: "Telephone Transmission over Long Distances." October, 1923.
 Hitchcock: "Applications of Long-Distance Telephony on the Pacific Coast." December, 1923.
 Jones: "The Nature of Language." April, 1924.
 Maitin and Fletcher: "High-Quality Transmission and Reproduction of Speech and Music." March, 1924.
 Casper: "Telephone Transformers." March, 1924.
 Martin: "The Transmission Unit." June, 1924.
 Harden: "Practice in Telephone Transmission—Maintenance." December, 1924.
 Ferris and McCurdy: "Telephony Circuit Imbalances." December, 1924.
 Kellogg: "Design of Non-Distorting Power Amplifiers." May, 1925.
 Discussion on above. June, 1925.
 Maxfield and Harrison: "Methods of High-Quality Recording and Reproducing of Music and Speech Based on Telephone Research." March, 1926.
 Nance and Jacobs: "Transmission Features of Transcontinental Telephony." November, 1926.
 Espenschied: "Radio Broadcast Coverage of City Areas." January, 1927.
 Discussion on above. April, 1927.

PROCEEDINGS OF THE INSTITUTE OF RADIO ENGINEERS

Obtainable from The Institute of Radio Engineers, 37 West 39th St., New York.

Espenschied: "Applications to Radio of Wire Transmission Engineering." October, 1922.
 Nichols and Espenschied: "Radio Extension of the Telephone System to Ships at Sea." June, 1923.
 Baker: "Description of the General Electric Company Broadcasting Station at Schenectady, N. Y." August 1923.
 Baker: "Commercial Radio Tube Transmitters." December, 1923.
 Little: "KDKA, the Radio Telephone Broadcasting Station of the Westinghouse Electric and Manufacturing Company, East Pittsburgh, Pa." June, 1924.
 Nelson: "Transmitting Equipment for Radio Telephone Broadcasting." October, 1924.
 Weinberger: "Broadcast Transmitting Stations of the Radio Corporation of America." December, 1924.

Cummings: "Recent Developments in Vacuum-Tube Transmitters." February, 1925.
 Heising: "Production of Single Side-Band for Transatlantic Radio." June, 1925.
 Oswald and Schelling: "Power Amplifiers in Transatlantic Radio Telephony." June, 1925.
 Espenschied, Anderson, and Bailey: "Transatlantic Radio Telephone Transmission." February, 1926.
 Bown, Martin, and Potter: "Some Studies in Radio Broadcast Transmission." February, 1926.
 Jensen: "Portable Receiving Sets for Measuring Field Strengths at Broadcasting Frequencies." June, 1926.
 Little and Davis: "KDKA." August, 1926.
 Goldsmith: "Reduction of Interference in Broadcast Reception." October, 1926.
 Crossley: "Piezo-Electric Crystal-Controlled Transmitters." January, 1927.

In addition to the above engineering articles, the reader interested in the technique of practical broadcasting may be referred to the twenty short papers on various aspects of broadcast operation which have appeared in this department since September, 1925. These discussions have been on such subjects as "Microphone Placing," "Wire Lines," "Multiple Pick-Up," "Equalization," "Calculation of Gain," "Modulator Plate Current Variation," "The Condenser Transmitter," "Studio Design," etc. The object of the treatment in each case has been to aid broadcasters looking for information on their immediate problems, rather than to attain originality or high engineering calibre.

Technical Problems for Broadcasters. No. 2

A RECEIVING set is equipped with an output tube capable of delivering energy to a loud speaker, without distortion, at a level of not over +10 TU. It is normally tuned to a given broadcasting station and so adjusted that the audio output is +8 TU, allowing an overload margin of 2 TU. All other factors remaining constant, the power of the broadcasting station is doubled. By how many TU will the output tube of the receiving set be overloaded? Give all the steps in the solution. Answer on page 170.



"THERE ARE STILL SOME WHO FAIL TO DIG DOWN FOR \$6 A YEAR"

Technical Problems for Broadcasters. No. 3.

THE ratio of energy between fortissimo and pianissimo passages of an orchestra is 1,000,000:1. The orchestra is reproduced without distortion by a public address system in another room. The operator brings up the pianissimo passages so that they are over the room noise level at a certain point near the projector, always returning to a base gain level for louder parts of the performance. The faintest pianissimo passages produce in the air at this point an R.M.S. pressure of 0.0001 dynes per square centimeter. The loudest passages produce a corresponding pressure of 1 dyne per square centimeter. By how many TU did the P.A. operator bring up the gain during pianissimo intervals? Solution on page 170.

Thirteen Years Ago

THE Institute of Radio Engineers was founded, as all good and even middling radio men know, in 1912, by the amalgamation of the "Society of Wireless Telegraph Engineers" and the "Wireless Institute." At the time of its formation the Institute boasted of less than 50 paid-up members. I do not know just how many members are on the rolls now, but Mr. Robert H. Marriott, the first President. re-

marked to me the other day that at the present rate of increase the membership is headed for the ten thousand mark within a few years. The recently compiled index to the *Proceedings*, the engineering publication of the organization, which was issued quarterly in 1913 and now goes out to the members monthly, contains references to every conceivable radio subject, from acoustic tuning to wired wireless, and all the authors, great and small, from Alexanderson to Zenneck, are represented. I wrote an article some time ago, pointing out the advantages of membership to all serious-minded radio men, but it appears that there are still some strange creatures in the profession who fail to dig down for \$6.00 a year, to their own advantage. The Institute needs them, but they need the Institute a lot more, if they only knew it. The Secretary will be pleased to mail application blanks from 37 West 39th Street, New York.

Important as this is, it is not precisely what I started to write about. The fact is that I thought it might amuse some of the faithful customers to peruse a few personal excerpts from Volume 2

American amateur signals on the other side of the Atlantic (From 1 BCG, in 1921—listen to the Radio Club of America contingent yell!)—he was Radio Inspector for the Brazilian Government, and lived, then as now, in New Jersey. Presumably the Brazilians had placed an order for some radio equipment in the United States, and Mr. Godley was there to see that they did not get any celluloid spark gaps in the shipment. DeLoss K. Martin had not yet issued from the Polytechnic College at Oakland, California; to-day he is known as a colleague of Dr. Ralph Bown, the President of the Institute, and Mr. R. K. Potter, in the work which resulted in the paper on "Some Studies in Radio Broadcast Transmission," printed in the *Proceedings* for February, 1926, and recognized as one of the most brilliant pieces of research in all radio history. Elmo Neale Pickerill was exercising his perfect fist as an instructor at the Marconi Wireless Telegraph Company's school. Nowadays, as Chief on the *Leviathan*, he probably seldom touches a key. I should like to hear the fast but unhurried dots and dashes rippling once more from under his hand—I who was brought up among such artists of the brass lever, and now must earn my living among artists of another kind.

But to continue. There stands the name of Harry Sadenwater, now the engineer in charge of the General Electric Company's chain of broadcast stations, from Schenectady to Oakland. In 1914 Mr. Sadenwater was the radio instructor at the East Side Y. M. C. A. in New York City. If you didn't hear him in those days you missed another copper-plate hand, and I do not refer to calligraphy. Thomas M. Stevens, Superintendent of the Eastern Division of the Marconi Company then, runs the whole Marine Department of the Radio Corporation now. Behold also Ellery W. Stone, a student at the University of California in 1914, and President of the Federal Telegraph Company to-day. Bowden Washington, an engineer of Cutting and Washington and Colonial Radio prominence these latter days, was testing for Clapp-Eastham thirteen years ago. Joseph O. Mauborgne was a First Lieutenant in the United States Army; First Lieutenants become Colonels. Allen D. Cardwell, one of the manufacturers who, with the advent of broadcasting, continued to take pride in turning out precise and decent apparatus when junk sold just as well, may have learned his craft as Chief Engineer of the American Telegraph Typewriter Company. Lewis Mason Clement, Chief Engineer of Fada, was a Shift Engineer in the Marconi station at Kahuku, in the Hawaiian Islands. Edwin H. Colpitts, in 1914, was a Research Engineer of the Western Electric Company; one does not become an Assistant Vice-President of the American Telephone and Telegraph Company overnight. Of William H. Howard, now in charge of the tube division in the Radio Corporation's Technical and Test Department, I shall have more to say hereafter, in the "Memoirs." He was a Laboratory Assistant of the Marconi Company in the ancient days to which we are applying the pick and spade. And here appears the name of Arthur H. Lynch, a Radio Operator of the same Marconi Company, a radio manufacturer now, and once Editor of this magazine. Also Lee L. Manley, Assistant Service Manager of R. C. A., came from about the same cradle, save that his

title was "Radio Electrician." Did that mean that he got \$2.00 a month more, or less, in the old Marconi days? Never mind, none of us got much. But here is a genuine pioneer of not only the radio, but the telegraph and cable business, Edward Butler Pillsbury, in 1914 Assistant Traffic Manager of the same Marconi Company, and now Vice-President and General Manager of the Radio Real Estate Corporation of America. With Mr. Pillsbury's name we may well close the present account. All these were members of the Institute of Radio Engineers in 1914, and all are members now.

Radio Revolutionized Again

ONCE again a revolutionary radio invention is heralded. A good-sized headline in one of the conservative journals, followed by 112 lines of type, informs us that "Crystal Device Turns Phone into Complete Radio System."

How? There are two pins, which connect the crystal detector or vacuum tubes—for, marvelous to relate, either may be used—to the telephone line and ground. The telephone line then acts as an antenna. The device may be clamped to the telephone, the only apparatus required for this job being a telephone and a clamp. The inventor is a "tea specialist" employed by the Department of Agriculture. "As paradoxical as it may seem," states the article, "this invention was conceived in a dearth rather than a wealth of radio knowledge. The inventor is recognized the country over as an authority on teas, but he boldly admits that he is not versed in the elemental principles of radio."

Patent specifications have been drawn up. "Patents are pending," as a sweetly familiar phrase has it. Alas, in the present instance, they will never cease to pend. Fifteen years ago some obscure amateur, whose name had been forgotten and whose body may be dust, first connected power and telephone lines, capacitively and even

conductively, to his primitive receiver, and heard m.c.c. out on the Cape sending press in code to the Atlantic. If someone is cruel enough and has the time, let him dig up the precise number of *Modern Electrics* in which the discovery was chronicled. And let the telephone companies whose lines are unbalanced by this recrudescence of the marvel deal gently with the tea expert of Washington, D. C. He is, after all, a tea expert.

Solution to Technical Problem No. 2

THE power in the transmitting antenna, expressed in terms of antenna current and resistance, is:

$$P_t = I_t R_t \tag{1}$$

$$\text{Whence } I_t \propto \sqrt{P_t} \tag{2}$$

From the Austin-Cohen formula and the theory of radio propagation, we know that the current and voltage in a receiving antenna vary directly as the current in the transmitting antenna. That is:

$$I_r \propto I_t \tag{3}$$

$$\text{and } E_r \propto I_t \tag{4}$$

$$\text{Therefore } E_r \propto \sqrt{P_t} \tag{5}$$

That is, the radio-frequency voltage impressed on the receiver varies as the square root of the power in the transmitting antenna. This holds through the r. f. amplifier of the receiver, so that the voltage impressed on the grid of the detector (the second detector in a super-heterodyne receiver) varies as the square root of the power in the transmitting antenna. But, as the usual vacuum-tube rectifier follows a square law, the audio plate current or voltage varying as the square of the grid potential, we may write:

$$I_a \propto E_r^2 \propto P_t \tag{6}$$

where I_a is the audio or post-detection current in the receiver.

But, impedance remaining constant, the TU level in any circuit is given by:

$$TU = 20 \log_{10} \frac{I_1}{I_2} \tag{7}$$

as explained in previous technical articles, based on engineering literature, in this department.

Hence, in the output of the receiver, a change in level is given by:

$$G = 20 \log_{10} \frac{I_{a1}}{I_{a2}} \tag{8}$$

Referring to (6) above, we may rewrite (8) in the final form:

$$G = 20 \log_{10} \frac{P_{t1}}{P_{t2}} \tag{9}$$

Equation No. 9 is the expression for level changes in the output of the receiver, in terms of different transmitter powers. The equation having been derived, the problem practically solves itself. The gain, with the doubling of power at the transmitter, is:

$$G = 20 \log 2 = 20 (0.301) = 6.0 \text{ TU}$$

As, by the conditions of the problem, the overload margin of the output tube is only 2.0 TU, with the doubling of transmitter power the receiver will overload by 6 minus 2, or 4 TU.

Solution to Technical Problem No. 3

THIS problem is not as complicated as it looks. We are given that the sound pressure in air at a certain point varies between 1.0 and 0.0001 dynes per square centimeter. This pressure is expressed in force per unit of area. By definition, energy is expressed as a force acting through a given distance. If E represents energy, F force, and d a distance through which F operates, then

$$E = Fd$$

$$\text{Hence } \frac{E_1}{E_2} = \frac{F_1}{F_2}$$

And since power is directly proportional to energy, we may also write for the power P that

$$\frac{P_1}{P_2} = \frac{F_1}{F_2}$$

By definition the telephonic gain variation in TU, as we have seen in previous articles and problems, is given by

$$TU = 10 \log_{10} \frac{P_1}{P_2}$$

Or, in the P. A. system described above, the gain range is given by

$$\begin{aligned} G_0 &= 10 \log_{10} \frac{F_1}{F_2} = 10 \log_{10} \frac{1.0}{0.0001} \\ &= 10 \log_{10} 10000 \\ &= 40 \text{ TU} \end{aligned}$$

The subscript "o" in the above expression stands for "out" or "output."

We are also given that the orchestra itself plays with a power ratio of 1,000,000:1, so that the gain range into the P. A. system is

$$G^1 = 10 \log_{10} 1000000 = 60 \text{ TU}$$

Therefore the answer is that the operator narrowed the volume range by 60 minus 40, or 20 TU.

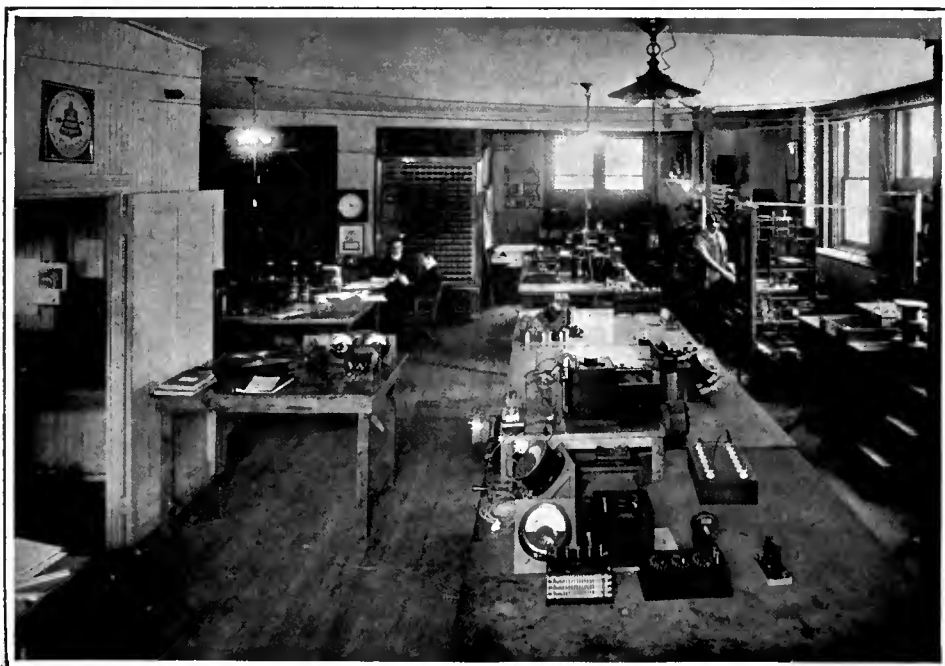

A RADIO LABORATORY OF A DECADE AGO

This picture was taken in 1917 in the college of the City of New York. Doctor Goldsmith is sitting with face to the camera and Mr. Julius Weinberger, now of the Radio Corporation, is at his left. Carl Dreher is to the right of the picture, adjusting the Marconi transmitter

Description of a Short-Wave Station



Details of the 500-Watt Crystal-Controlled Transmitter at 2 AG—The Four-Tube Short-Wave Receiver—A Radio Club of America Paper



By C. R. RUNYON, JR.

THE TRANSMITTER

THE short-wave crystal-controlled transmitter at radio station 2 AG employs seven transmitting tubes in the following combination: One UX-210 as a crystal oscillator tube; two UX-210's in the first intermediate push-pull amplifier; two UV-203-A's in the second intermediate push-pull amplifier; two UV-204-A's in the push-pull radio-frequency amplifier.

A schematic diagram of the crystal oscillator stage, together with its power supply, is shown in Fig. 1. The crystal is connected between the grid and filament terminals of the UX-210 crystal oscillator tube. The crystal used has a fundamental frequency of 3665 kc. (81.9 meters), so, in view of the fact that this station transmits on the 80-meter band, there are no frequency multiplier stages between the crystal oscillator and the antenna system, straight amplification being all that is required.

While we are discussing the grid circuit of the oscillator, it is logical that we consider the system of modulation that can be employed when it is desired, as modulation is effected in this circuit.

When the transmitter is in operation, the chopper disc (shown in Fig. 1) rotates at such a speed that it opens and closes the circuit through the primary winding of the modulation transformer (T_1) at an audio-frequency rate. The shunt across the chopper contacts is removed when the set is in operation, by virtue of the fact that relay No. 5 is energized at that time.

When the circuit is closed through the chopper contacts, a direct current flows through the primary winding of the modulation transformer (T_1), this current being supplied by a 6-volt storage battery, and being limited by the 50-ohm rheostat (R_4) and the resistance of the primary winding in question.

Every time the circuit through the chopper contacts is closed, we get a direct-current flow through the primary winding of (T_1), which sets up a field which cuts through the secondary winding of (T_1) and produces a potential "kick" across it. This voltage "kick" is passed on to the terminals of the crystal oscillator, and subsequently to the grid of the first amplifier tube. The effect of each one of these "kicks" is to change the frequency, right at the source; hence, the frequency of the transmitted signals is also changed.

The amount of this change, as near as the ear can tell, is between 500 and 1000 cycles. Thus, by this novel method of modulation, the frequency of the transmitted signals is changed through a band 500 to 1000 cycles wide, at an audio-frequency rate (the rate of make and break at the chopper contacts).

Plate voltage is supplied to the crystal oscillator tube from a full-wave rectifier system which employs two UX-216-B rectifier tubes.

This plate supply lead is prevented from offering a radio-frequency shunt across the crystal oscillator tube output circuit by means of the radio-frequency choke coil RFC₂ which is inserted in series with it. A d.c. milliammeter (0-100 mils.) is connected in series with this plate lead to indicate the plate current drawn by this tube.

The blocking condenser C_7 , which has a capacity of 0.002 mfd., bypasses radio-frequency energy, but prevents the coil L_1 from short-circuiting the d.c. plate supply.

The output circuit of the crystal oscillator tube is tuned to 80 meters by means of the 0.0005-mfd. variable condenser C_8 and the coil L_1 . The "0 to 3" thermo-ammeter, A_2 , indicates the radio-frequency current circulating in the output circuit of the crystal oscillator tube.

The filament of this tube is supplied with alternating current from one of the low-voltage windings on the Acme 200-watt power transformer, T_2 . This filament current is controlled by means of the 2-ohm General Radio rheostat, R_2 . C_4 and C_5 are 0.002-mfd. radio-frequency bypass condensers.

The filaments of the two UX-216-B rectifier tubes are heated by means of current from another low-voltage winding on transformer T_2 . The plates of the rectifier tubes are supplied with high-voltage alternating current from a secondary winding of T_2 which has a potential of 550 volts (r. m. s.) between its extremities and its mid-tap. The filament current to the rectifier tubes is limited by the General Radio 2-ohm rheostat, R_3 .

In the rectifier filter circuit there are two 2-mfd. condensers and one 10-mfd. condenser for smoothing, designated as C_1 , C_2 , and C_3

respectively. Two 30-henry chokes, X_1 and X_2 , are also used in this filter circuit. The high-voltage direct-current output of this No. 1 rectifier can be switched either to the plate of the crystal amplifier tube, or the plates of the tubes in a receiver, by means of the switch S_1 .

The output voltage of the rectifier can be controlled to a certain extent by means of the 30-ohm rheostat R_1 . When the master control switch at the operator's desk is thrown to the "send" position, relay No. 3 closes, closing the circuit through the primary winding of the power transformer, T_2 , and thus lighting the filament of the crystal oscillator tube and applying plate potential to the crystal oscillator tube. Relay No. 5 also closes when the master control switch is thrown to the "send" position, and the resultant action of this relay is to remove the shunt across the chopper contacts.

When the master control switch is returned to the "receive" position, the circuit to the chopper motor is opened and it starts to slow down. The main function of relay No. 5 is to place a shunt across the chopper contacts when the master control switch is in the "receive" position, so that the make and break of the contacts will not cause Q R M (interference) when the chopper motor is slowing down.

Energy is transferred from the crystal oscillator tube output circuit to the input circuit of the first intermediate amplifier (the latter being push-pull, using two UX-210's), by means of the inductive coupling between the two coils, L_1 and L_2 , the former being in the output circuit of the crystal oscillator, and the latter being in the input circuit of the first intermediate push-pull amplifier.

The mid-tap on the coil L_2 is connected to ground through a 45-volt bias battery, which applies a negative bias to the grids of both of the UX-210 tubes in the first intermediate amplifier. There is a 0.002-mfd. radio-frequency bypass condenser across this bias battery.

FIRST INTERMEDIATE AMPLIFIER AND ITS POWER SUPPLY

A SCHEMATIC diagram of the first intermediate amplifier is shown in Fig. 2. The attendant rectifier system is also shown in Fig. 2.

Midget, five-plate, neutralizing condensers are connected from the grid of one tube to the plate of the other in this stage of amplification, to neutralize the feed-back effect due to the inter-electrode capacity of the amplifier tubes used. This is an application of the "bridge" method of neutralization. For instance, when C_1 is adjusted to a value of capacity equal to the plate-grid capacity of the UX-210 whose grid is connected to No. 1 terminal in Fig. 2, the grid of the tube in question is at ground potential as far as the radio-frequency energy in the output cir-

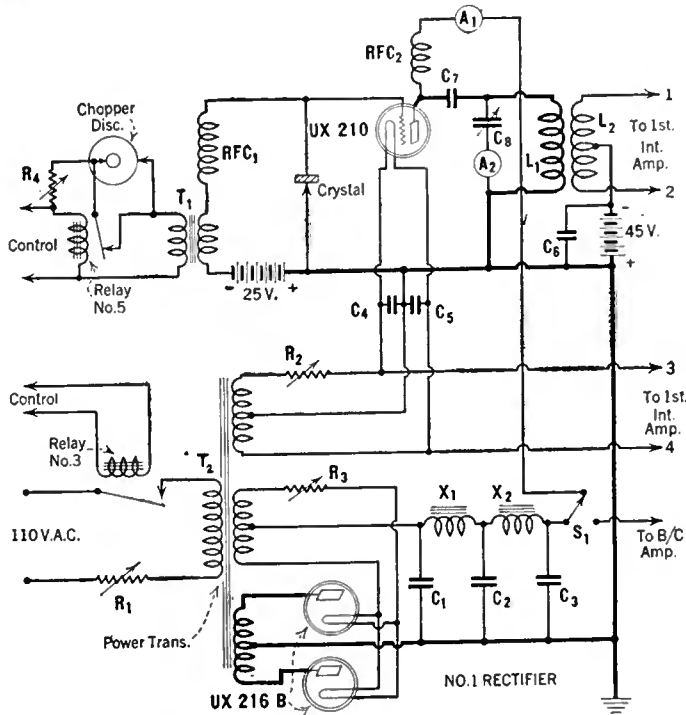

FIG. 1

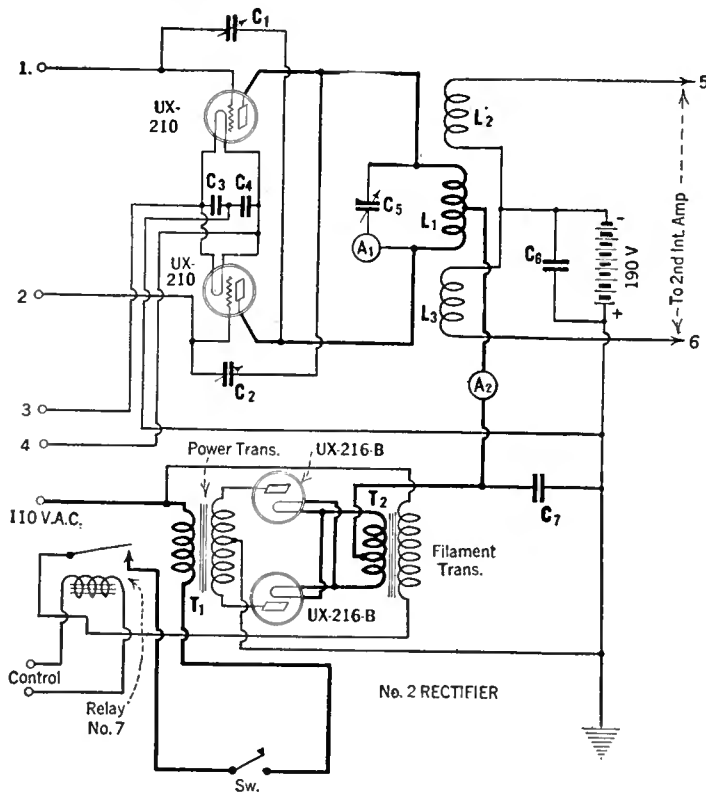

FIG. 2

cuit of this amplifier stage is concerned. Therefore, since the filament of this tube is metallically connected to ground, there can be no application of radio-frequency voltage to the grid of the tube in question, due to the radio-frequency energy in the output circuit of this amplifier stage.

The filaments of these two amplifier tubes are supplied with energy from the oscillator filament winding on the power transformer in the No. 1 rectifier assembly.

The output circuit of this stage of amplification is tuned by means of the coil L_1 and the 0.0005-mfd. variable condenser, C_5 . The radio-frequency current flowing in this tuned circuit is indicated by the "0 to 5" thermo-ammeter, A_1 .

The plate potential is supplied to the midpoint of the coil L_1 , and the plate current is indicated by the 0 to 150 mil. meter (A_2). The source of this high-voltage d. c. supply is the No. 2 rectifier system. This rectifier employs two UX-216-B rectifier tubes which receive their plate supply from the high-voltage secondary winding of a step-up transformer, T_1 .

A separate filament transformer is used to supply filament heating energy to the two rectifier tubes used, due to the fact that keying is effected by opening and closing the circuit through the primary winding of the power transformer, T_1 , which removes and applies, respectively, high-

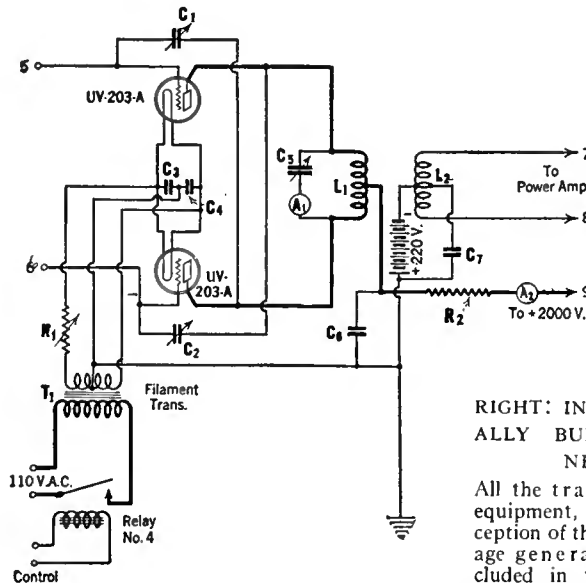

FIG. 3

voltage rectified a. c. to the plates of the two tubes in this amplifier stage.

If the filaments of the tubes in this No.2 rectifier were energized from a low-voltage winding on the transformer T_1 , keying could not be satisfactorily effected, due to the time lag involved in bringing the rectifier tube filaments up to normal operating temperature, once the circuit through the primary winding of the transformer is closed.

When the master control switch is thrown to the "send" position, relay No. 7 closes, thus closing the circuit to the primary winding of the high-voltage transformer T_1 , this circuit being under the control of the transmitting key.

Radio-frequency energy is induced into the input circuit of the second intermediate amplifier by means of the inductive coupling between L_1 in the output circuit of the first intermediate amplifier and L_2 and L_3 in the input circuit of the second intermediate amplifier.

The mid-point between the coils L_2 and L_3 is connected to ground through the 190-volt bias battery which maintains a negative bias on the grids of the two UV-203-A tubes in the second intermediate amplifier stage. This bias battery is bypassed by the radio-frequency bypass condenser, C_6 .

SECOND INTERMEDIATE AMPLIFIER

THE schematic diagram of this stage of amplification is shown in Fig. 3. The "bridge" method of neutralization is used in this amplifier stage and is effected by means of the two neutralizing condensers C_1 and C_2 . The output circuit of this push-pull amplifier is tuned by means of the coil L_1 and the condenser C_5 . The circulating current in this tuned circuit is indicated by the "0 to 10" thermo-ammeter, A_1 .

The filaments of these two 50-watt tubes are supplied with filament heating energy from a separate transformer T_1 , this current being controlled by means of the rheostat R_1 . The plate supply for these two tubes is obtained from a 2000-volt d.c. generator, a plate resistor, R_2 , functioning to drop the plate voltage from 2000, at the generator source, to 1000 volts at the plates of the 50-watt tubes in this stage of amplification. There is a 0.002-mfd. bypass condenser from the low side of R_2 to ground.

When the master control switch is closed, it operates relay No. 4, which closes the circuit through the primary winding of the filament transformer T_1 for the two 50-watt tubes in this second intermediate amplifier stage.

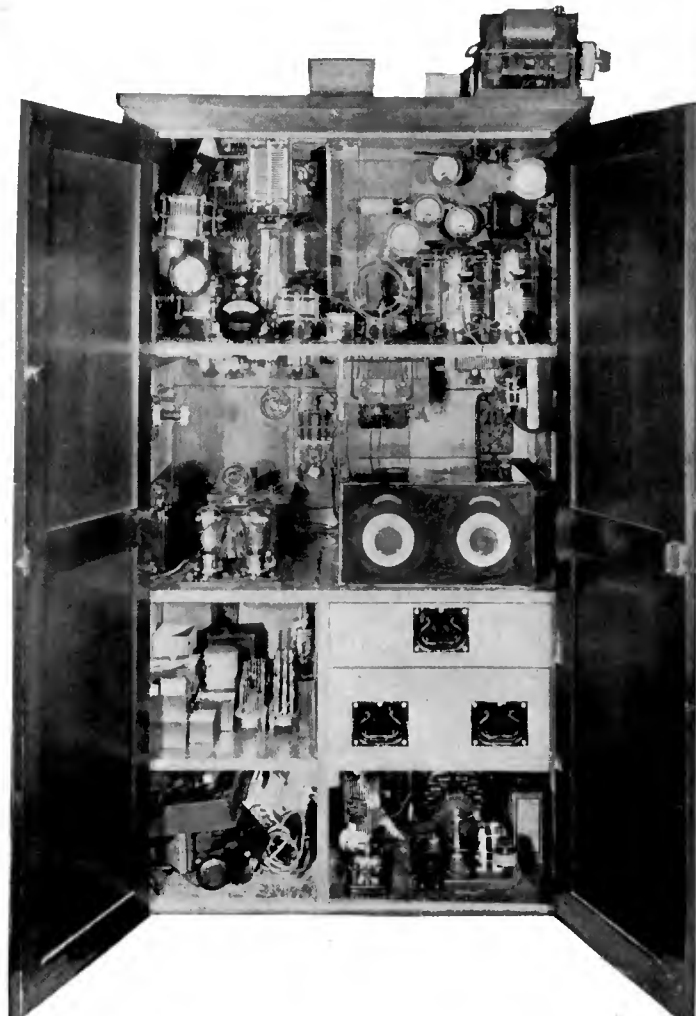

RIGHT: IN A SPECIALLY BUILT CABINET

All the transmitting equipment, with the exception of the high-voltage generator, is included in the cabinet

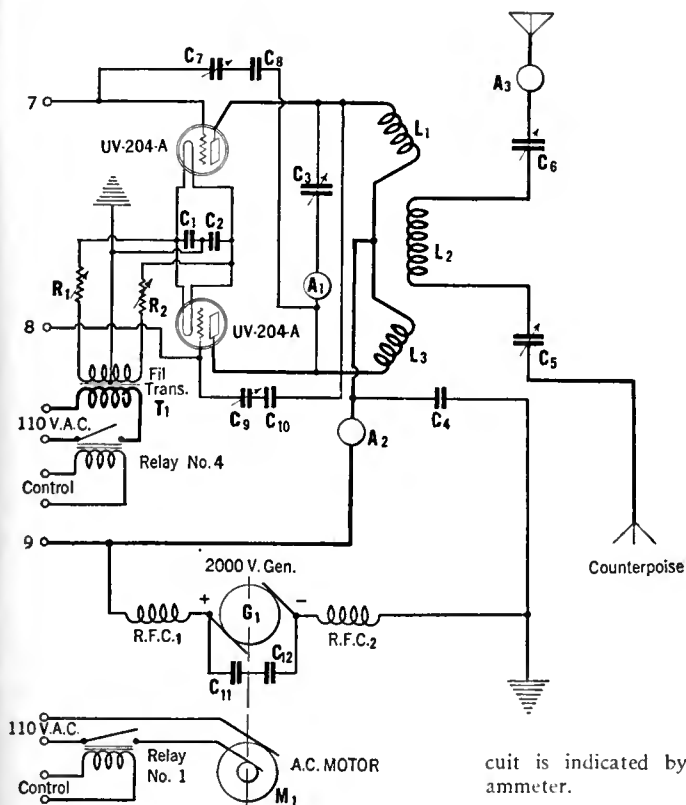

FIG. 4

circuit is indicated by the "0 to 5" thermoammeter.

COMPLETE TRANSMITTER ASSEMBLY

The radio-frequency energy in the output circuit of this stage of amplification is induced into the input circuit of the succeeding stage, which is also push-pull, by means of the inductive coupling between the coil L_1 in the output circuit of the 50 watters, and the coil, L_2 , in the input circuit of the power amplifier stage.

The mid point of the coil L_2 is connected to ground through a 220-volt bias battery, and, since the extremities of L_2 are connected to the grids of two UV-204-A 250-watt power tubes, the grids of the tubes in question are held 220 volts negative. There is a radio-frequency bypass condenser, C_7 , across this bias battery.

POWER AMPLIFIER AND ITS POWER SUPPLY

THE schematic diagram of the power amplifier stage of amplification, its power supply, and the antenna system at station 2 AG, is shown in Fig. 4.

Filament heating energy for the two UV-204-A tubes in this stage of amplification is supplied from a separate step-down transformer, T_1 . The filament current is controlled by means of two rheostats, R_1 and R_2 .

Here again, the "bridge" method of neutralization is used, and is effected by neutralizing condensers, C_7 and C_9 . The condensers C_8 and C_{10} , which are in series with the neutralizing condensers, are radio-frequency bypass condensers, and simply function to cut down the voltage drop across the neutralizing condensers and thus prevent the possibility of their arcing over.

The power amplifier output circuit is tuned by means of the coils L_1 and L_3 and the variable condenser C_3 . The circulating current in this tuned circuit is indicated by the "0 to 20" thermoammeter. The mid-point between the two plate coils is connected to the positive 2000-volt terminal of the high-voltage d. c. generator through the "0 to 1000" milliammeter, A_2 .

The high-voltage plate generator is driven by an a. c. motor which operates on 110 volts. When the master control switch is closed, relay No.

1 operates and closes the 110-volt circuit to the motor of the high-voltage generator set. Relay No. 4 also operates when the master control switch is closed, closing the circuit through the primary winding of the filament transformer T_1 which supplies filament heating energy to the two 250-watt tubes in this stage of amplification.

The energy in the output circuit of the power amplifier is fed into the antenna system by means of the inductive coupling between the power amplifier output coils, L_1 and L_3 , and the antenna coil, L_2 . A counterpoise is used in the antenna system at 2 AG and the whole arrangement is tuned by means of the variable condensers C_5 and C_6 . The current in the antenna circuit is indicated by the "0 to 5" thermoammeter.

the entire transmitter does not include the control relays or the power supply units.

CONTROL RELAY SYSTEM

WHEN the operator at station 2 AG closes the master control switch to the "send" position, there are a great many actions that take place. This can best be explained by a study of Fig. 6, which shows the control relay system alone.

When the single-pole single-throw switches, S_1 and S_2 , are closed, the control relays are under the control of the master switch. The pilot lamps are lighted when S_1 and S_2 are closed. The former is in an 8-volt circuit and the latter is in a 6-volt circuit.

With the master control switch thrown to the "transmit" position ("T" in the diagram), the following actions take place:

- (A). Relay No. 2 closes. Relay No. 1 is thrown on the 110-volt a. c. line and it closes. When relay No. 1 closes, 110 volts a. c. is applied directly across the terminals of the a. c. motor which drives the high-voltage d. c. generator for the plates of the two 50 watters, and the plates of the two 250 watters.
- (B). Relay No. 3 closes. The 110-volt a. c. circuit is closed through the primary winding of the power transformer in the No. 1 rectifier assembly.
- (C). Relay No. 4 closes. An a. c. voltage of 110 is applied to the primary winding of the filament transformer for the two UX-216-B rectifier tubes in No. 2 rectifier.

A similar voltage is applied to the primary winding of the filament transformer for the two UV-203-A tubes in the second intermediate amplifier circuit.

A voltage of 110 is applied to the primary winding of the filament transformer for the two UV-204-A tubes in the power amplifier.

One hundred and ten volts a. c. is applied to the terminals of the motor that drives the chopper disc.

- (D). Relay No. 5 opens. The shunt across the chopper contacts is removed.
- (E). Relay No. 6 closes. The terminals of the headphones are connected to the output of the monitor receiver which allows the operator to hear the quality of his outgoing signals.
- (F). Relay No. 7 closes. The circuit from the 110-volt a. c. supply, through the primary winding of the plate transformer for the No. 2 rectifier, is closed.
- (G). Relay No. 8 closes. The A battery circuit to the filaments of the tubes in the monitor receiver is closed.
- (H). The 8-volt control battery is connected in series with the modulation transformer and the chopper contacts.

A PHOTOGRAPH on page 172 shows the complete transmitter assembly at station 2 AG. The entire equipment is included in a cabinet built for the purpose, with the exception of the high-voltage generator which is located in the basement.

The chopper unit is located in the lower right-hand corner of the cabinet. The crystal oscillator and first intermediate amplifier are located on the middle shelf behind a shield painted black. No. 2 rectifier is just to the left of this black box, and rectifier No. 1 is located on the top of the cabinet.

The second intermediate amplifier is located in the upper right corner, and the power amplifier is to the left of the latter, in the upper left-hand corner of the cabinet. The operators' desk is just to the left of this cabinet.

A schematic diagram of the transmitter is shown in Fig. 5. Note that the diagrams of the various stages have given the complete details concerning each stage, whereas the diagram of

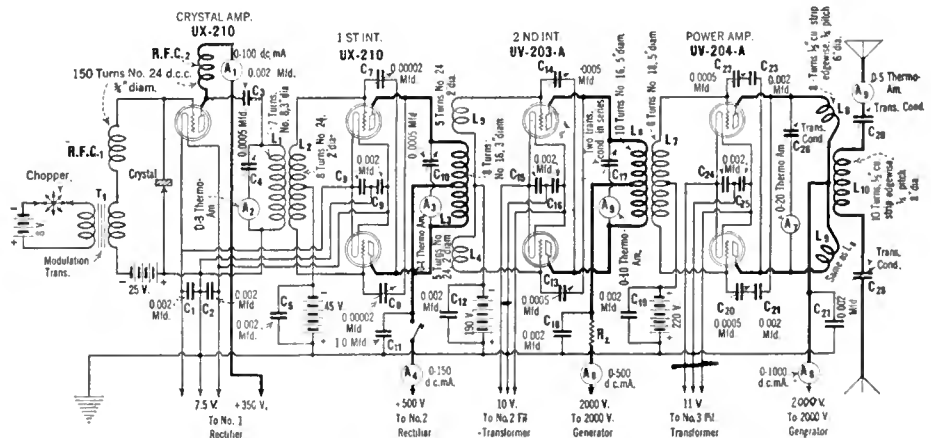

FIG. 5

A diagram of the complete 500-watt transmitter, 2 AG. The control relays and power supply equipment has been omitted in the diagram. This diagram combines Figs. 1, 2, 3, and 4, but the lettering of the parts is different

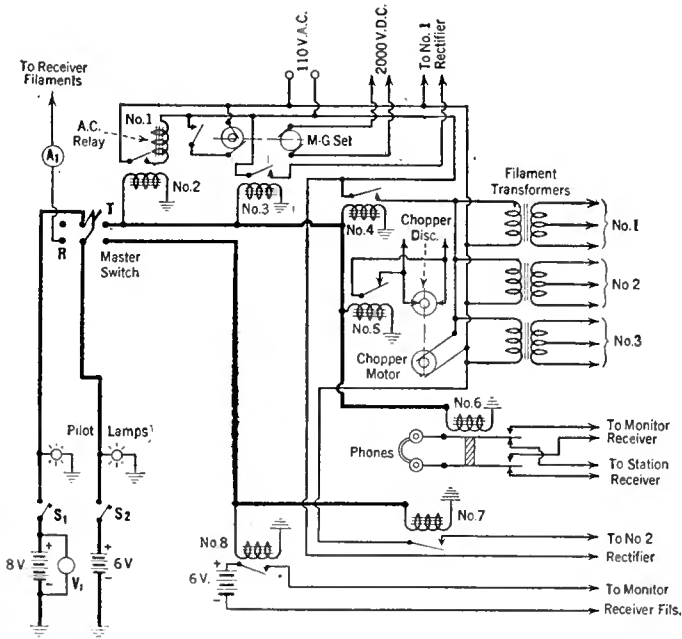

FIG. 6

The control relay system at 2 AG. Filament Transformers: No. 1 supplies filaments of rectifier tubes in No. 2 rectifier for the first intermediate amplifier; No. 2 for filaments of the second intermediate amplifiers (UV-203-A's); No. 3 for filaments of power amplifier tubes (UV-204-A's). The functioning of this control relay system is explained in the text on page 173

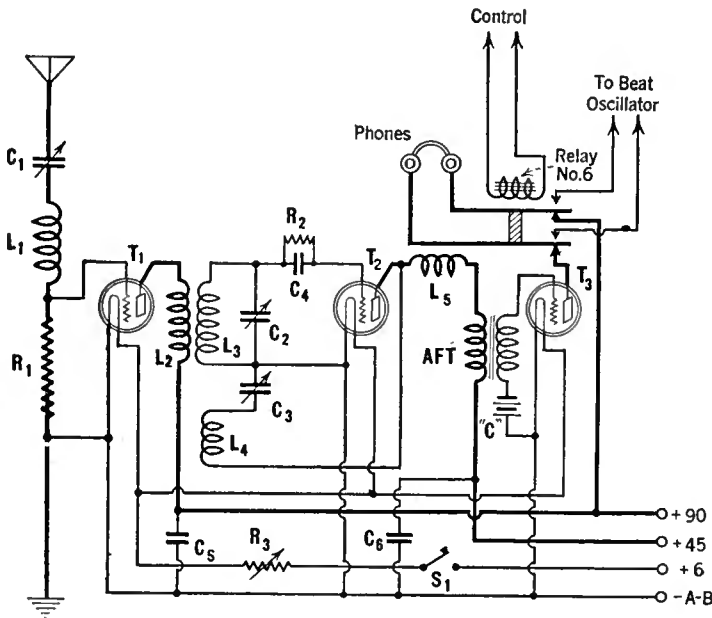

FIG. 8

The short-wave receiver. The following are the constants of the circuit: AFT, audio-frequency transformer (ratio 6-1); L₁, 50 turns No. 16 d. c. c. 3 inches diameter; L₂, 6 turns No. 16 bare wire, spaced wire width, 3 inches diameter; L₃, 23 turns No. 16 bare wire, spaced wire width, 3 inches diameter; L₄, 4 turns No. 16 bare wire, spaced wire width, 3 inches diameter; L₅, 175 turns No. 34 d. s. c. 1 inch diameter; C₁, 0.0005-mfd. variable condenser; C₂, 0.000075-mfd. variable condenser; C₃, 0.00025-mfd. variable condenser; C₄, 0.00025-mfd. fixed condenser; C₅, 0.1 mfd. fixed condenser; C₆, 0.1-mfd. fixed condenser; R₁, 50-ohm fixed resistance; R₂, 3-megohm grid leak; R₃, 6-ohm rheostat; S₁, Filament control switch (on master control switch); relay No. 6, 6-volt, d. p. d. t. The coils given above are for the 80-meter band. Those used for the 40-meter band are as follows: L₃, 10 turns No. 16 bare wire, spaced wire width, 3 inches diameter; L₄, 3 turns No. 6 bare wire, spaced wire width 3 inches diameter.

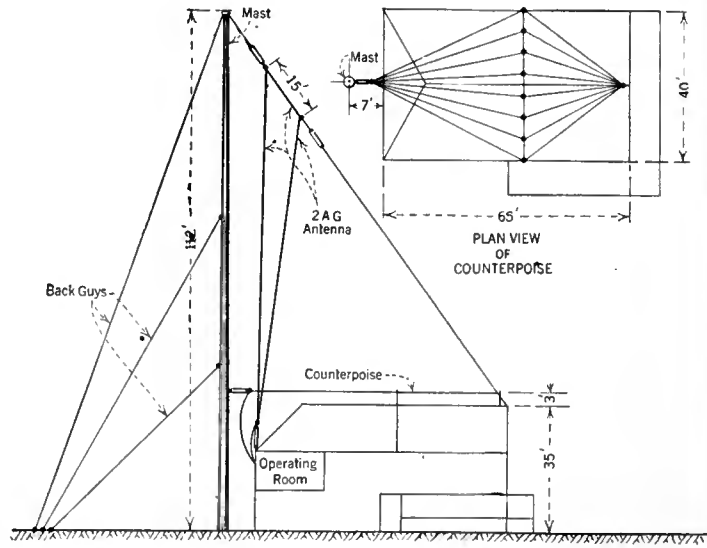

FIG. 7

The antenna system at 2 AG.

When the master control switch is thrown to the "receive" position, which is indicated by "R" in Fig. 6, all the control relays, with the exception of relay No. 5, open, and the contacts

of this latter relay close, thus shunting the chopper contacts during the period that the chopper motor is coming to a stop. It is well to note that the filaments of the short-wave receiver are turned on by putting the master control switch in the "receive" position, and the headphones are disconnected from the output of the monitor receiver, and connected to the output of the monitor receiver, and connected to the output of the short-wave receiver, this latter action being taken care of by relay No. 6.

THE ANTENNA SYSTEM

A DIAGRAM of the antenna system is shown in Fig. 7. The antenna consists of two verticals to the extremities of a very short flat-top, the latter being an active part of the antenna system, which is insulated from a guy wire which extends from the top of a 112-foot mast to

the top of the roof at the front of the house. The mast itself has three sets of back guys, this mast being about 18" in diameter at the base and 6" in diameter at the top.

The counterpoise is arranged on the top of the roof of the house, as shown in the plan view in the upper right corner of Fig. 7.

SHORT-WAVE RECEIVER

THE schematic diagram of the short-wave receiver used at 2 AG is shown in Fig. 8.

The first tube in this receiver, T₁, is simply a coupling tube. The antenna is connected to the grid of the receiver through the variable 0.0005-mfd. condenser C₁ and the coil L₁. There is a 50-ohm resistor, R₁, between the grid and filament of the coupling tube, and the filament is grounded.

The radio-frequency energy in the output circuit of the coupling tube is passed on to the input circuit of the detector tube through the medium of the inductive coupling between the coils L₂ and L₃, the latter being tuned to the incoming signals by means of the 0.000075-mfd. variable tuning condenser C₂

Regeneration is accomplished by means of the inductive coupling between the feed-back coil L₄ and L₃, and the tuning is effected by the variable condenser C₂. The function of C₃ is to limit the amount of radio-frequency current flowing in the feed-back circuit, hence also limiting the amount of regeneration.

L₅ is a radio-frequency choke and AFT is the first audio-frequency interstage transformer. Only one stage of audio-frequency amplification is shown on the diagram, although in the actual receiver there are two stages.

C₅ is both a radio- and an audio-frequency-bypass condenser, and C₆ is an audio-frequency bypass condenser.

MONITOR RECEIVER

THE monitor receiver is just an ordinary receiver which is tuned so that one of its harmonics beats with the fundamental frequency of the transmitter. In this way it is possible to monitor the outgoing signals by picking up a small amount of signal energy without danger of blocking the tubes in the receiver.

RADIO BROADCAST is the official publication of the Radio Club of America, through whose courtesy, the foregoing paper has been printed here. RADIO BROADCAST does not, of course, assume responsibility for controversial statements made by authors of these papers. Other Radio Club papers will appear in subsequent numbers of this magazine

TOBE — EBY
VAN DOORN
FROST

UNIPAC

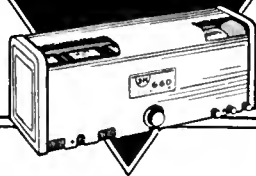

SILVER MARSHALL
Q.R.S. — LYNCH
WARD-LEONARD

The Unipac is Here!



amplifier has the same features of rising low note frequency gain and 5,000 cycle cut-off that have made 220's and 221's the largest selling high-grade audio transformers on the market—two features at first ridiculed by experts, then accepted and next season to be found in the most advanced high-class equipment.

The power supply of the Unipac, unlike average power supplies, gives practically constant output, and is substantially the Reservoir B unit so highly endorsed by Keith Henney of Radio Broadcast Laboratory. It furnishes B supply to any radio set and A, B and C power to the amplifier stage—power constant, unfluctuating and free from "motor-boating" and "putting."

A Unipac added to your set provides it with the finest quality of reproduction, handling capacity to spare, and replaces all B batteries, operating as it does directly from the 105 to 120 volt, 60 cycle, house lighting socket. Even though you may discard your set for a newer model, the Unipac will improve any receiver you ever buy or build—will remain the last word in distortionless power amplification and B power supply for years to come. And its applications are not limited—it may be used as a two stage amplifier, or to electrify any phonograph by means of a standard record pick-up, loud speaker and the Unipac.

The Unipac kit, with all parts including steel chassis and case, is available in two models. Type 660 contains the most powerful of all receiving amplifiers, a push-pull stage with 230 and 231 transformers, and is priced at \$62.00. Type 660-B, with a slightly lower output level, includes a standard amplifier stage with 220 and 221 transformers, at \$57.00.

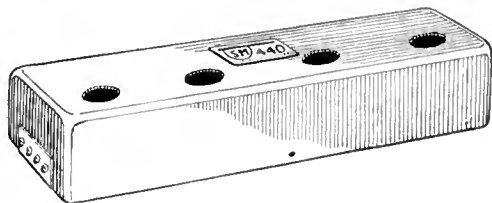

The 440 Jewelers' Time Receiver consists of three R. F. amplifier stages and a detector, accurately tuned in the S-M laboratories to exactly 112 K.C., Arlington's wavelength, thus insuring reception of but one station at a time absolutely without interference.

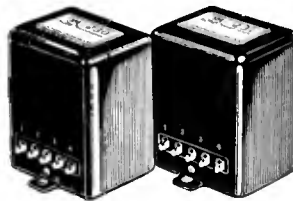

The remarkable tone quality of the Unipac—its tremendous undistorted power output—is made possible only through the use of the S-M push-pull transformers—the new 230 input and 231 output models. You too can enjoy this tone quality by incorporating them in your audio amplifier or power pack. They are priced at \$10.00 each.

SM

SILVER-MARSHALL, Inc.

838 West Jackson Blvd.

Chicago, U. S. A.

FROST-RADIO

Of Course!
Selected by
Radio Broadcast
 and
Mc Murdo Silver
 for the new
Silver-Marshall
UNI-PAC

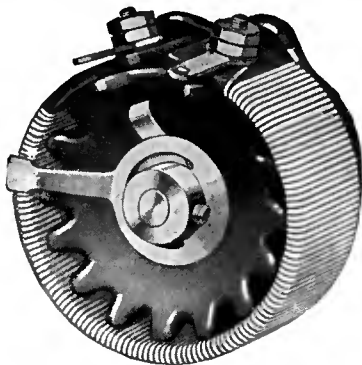

FROST-RADIO
No. 834 Special DeLuxe
1000 ohm Potentiometer

A New Heavy Duty Potentiometer wound on heat resisting flexible Bakelite strip. Has air-cooled construction with Bakelite frame, is single hole mounting and has attractive new style Bakelite knob. List: \$1.25.

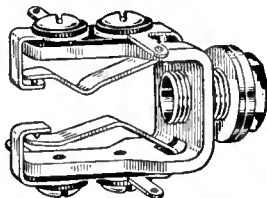

No. 951
GEM-JAC

This Double Circuit Gem-Jac has genuine Bakelite insulation, sterling silver contacts and occupies but 1 inch of space back of panel. List: \$.50.

FROST-RADIO



FROST-RADIO

No. 253 Cord Tip Jack

This handy No. 253 Cord Tip Jack has built-in spring clutch from which cord tip cannot be accidentally removed until clutch is released. Two pairs of these are used in the UNI-PAC. List, per pair: \$.30.

HERBERT H. FROST, INC.

Main Offices and Factory
ELKHART, IND.

Chicago New York Boston
 Philadelphia Los Angeles Pittsburgh
 Washington, D. C. St. Paul New Orleans
 Buenos Aires, Argentina

The Radio Broadcast LABORATORY INFORMATION SHEETS

THE RADIO BROADCAST Laboratory Information Sheets are a regular feature of this magazine and have appeared since our June, 1926, issue. They cover a wide range of information of value to the experimenter and to the technical radio man. It is not our purpose always to include new information but to present concise and accurate facts in the most convenient form. The sheets are arranged so that they may be cut from the magazine and preserved for constant reference, and we suggest that each sheet be cut out with a razor blade and pasted on 4" x 6" filing cards, or in a notebook. The cards should be arranged in numerical order. An index appears twice a year dealing with the sheets published during that year. The last index appeared on sheets Nos. 47 and 48, in November, 1926. This month an index to all sheets appearing since that time is printed.

The June, October, November, and December, 1926, issues are out of print. A complete set of Sheets, Nos. 1 to 88, can be secured from the Circulation Department, Doubleday, Page & Company, Garden City, New York, for \$1.00. Some readers have asked what provision is made to rectify possible errors in these Sheets. In the unfortunate event that any such errors do appear, a new Laboratory Sheet with the old number will appear.

The Information Service of RADIO BROADCAST is conducted entirely by mail, the coupon on page 191 being used when application is made for technical information. It is the purpose of these Sheets to supply information of original value which often makes it possible for our readers to solve their own problems. —THE EDITOR.

No. 105

RADIO BROADCAST Laboratory Information Sheet

July, 1927

Measuring R. F. Resistance of a Coil

NECESSARY EQUIPMENT AND PROCEDURE

THE job of measuring radio-frequency resistance is not an especially difficult one, although it requires considerable apparatus. The circuit diagram of the test circuit is given on this Sheet. The apparatus used should have the following characteristics:

OSCILLATOR—This represents a source of radio-frequency energy which should be adjusted to the

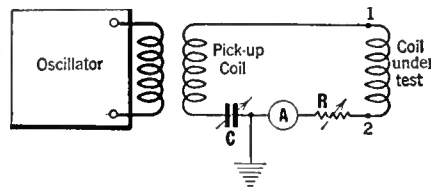

frequency at which the measurements are to be made. It should have plenty of power. In the Laboratory a 210 tube with at least 300 volts on the plate is generally used, but it is doubtlessly possible to use a 201-A as an oscillator with about 100 volts on the plate. The important point is that adjustments in the test circuit should produce no change in the energy delivered by the oscillator.

A—This is a radio-frequency milliammeter with a range of about 200 milliamperes or preferably

somewhat less. It may be a hot-wire or thermocouple meter, or an ordinary crystal detector used with a low-range d. c. milliammeter.

C—The condenser should be a very carefully constructed one because it is essential that its reactance be low and constant. It should preferably be a laboratory type instrument although a well made receiving condenser can be used.

R—This resistance must be continuously variable and must be non-inductive. A decade resistance box is well suited for this purpose.

PICK-UP COIL—The pick-up coil functions to pick up energy from the oscillator and feed it into the test circuit. It may consist of just a few turns of wire coupled just close enough to the oscillator so as to give a good deflection on the meter, A.

The procedure in making a test is quite simple. Start with zero resistance at R and once the test has started make no changes at all in the oscillator or in the position of the pick-up coil. The oscillator should be turned on and the condenser varied until the circuit is in *exact* resonance, this condition being indicated by a maximum reading noted on meter A. Points 1 and 2 are now short circuited and the condenser readjusted so as to again bring the circuit into resonance. The reading of the meter will now be greater than before because the resistance of the coil under test is no longer in the circuit. Now add resistance to the circuit at R until the meter reading is decreased to the same value as was noted above, and under such conditions the resistance R is equal to the r. f. resistance of the coil under test.

No. 106

RADIO BROADCAST Laboratory Information Sheet

July, 1927

The UX-240 Type Tube

GENERAL CHARACTERISTICS

THE UX-240 type tube is designed for use in resistance-coupled amplifiers and under proper conditions will give an effective amplification of about 20 per stage. The plate resistor used with this tube should have a value of 250,000 ohms and the B and C voltages should be 180 volts or 135 volts and 3 or 1.5 volts respectively. The coupling condensers should have a value of 0.05 mfd. and the grid leak resistance should be of 2 megohms. These values are correct when the tube is used as an amplifier. It can also be used as a C-battery type detector in which case the C voltage should be 3 volts for a plate voltage of 135 or 4.5 volts for a plate voltage of 180. The plate resistor, coupling condenser, and grid leak should have the same values as given above.

The general characteristics of this tube are as follows:

Filament Voltage	5.0 Volts
Filament Current	0.25 Amperes
Maximum Plate Voltage	180 Volts
Amplification Constant	30
Plate Impedance	150,000 Ohms
Plate Current	0.2 Milliampères

This tube can be used in any existing resistance-coupled amplifier provided the resistances used are of the proper value and the tubes are supplied with the proper A, B, and C voltages.

It is not possible to use this new tube in a transformer-coupled amplifier because its high plate

impedance will cause the transformer to have a rather sharp peak at some frequency. This fact, however, makes the tube very satisfactory as an amplifier for c. w. reception in short-wave receivers where we are interested in obtaining high amplification around 1000 cycles and very poor amplification at all other frequencies. The tube can also be used as a detector in a short-wave receiver.

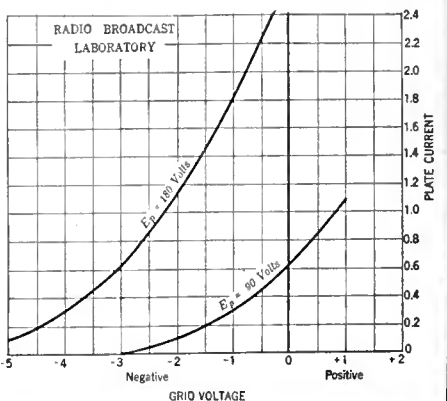

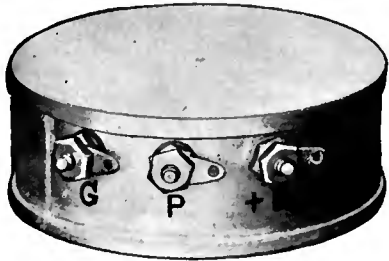

Shielded Tuned Radio Transformer, No. 30

SICKLES Diamond-Weave Coils

THE new Sickles Shielded Tuned Radio Transformer prevents both outside and local interference. It is remarkably compact, sharp tuning, sturdy. Sickles Diamond-weave coils have established an enviable reputation for low distributed capacity, low dielectric losses, and large range of frequency with small variable capacity.

The ideal coil for the Naald Localized Control Tuning Unit and for the Tru-phonic Catacomb Assembly.

There are Sickles Diamond Weave Coils for all Leading Circuits.

The F. W. Sickles Co.
132 Union Street
SPRINGFIELD, MASS.

COIL PRICES

- No. 30 Shielded Transformer...\$2.00 each
- No. 24 Browning-Drake..... 7.50 Set
- No. 18A Roberts Circuit..... 8.00 "
- No. 25 Aristocrat Circuit..... 8.00 "



Volume
With
Clarity

DOUBLE ENJOYMENT
From Any Set With

Burns LOUD SPEAKER

Why sacrifice the excellent reproducing qualities of a set by the use of an inferior speaker. With a BURNS it is possible to reproduce with amazing exactness every note of music and inflection of voice that the set can pick up. A trial will convince.

AT YOUR DEALER'S OR WRITE DIRECT
Our line will be displayed at the R. M. A. Trade Show, Stevens Hotel, Chicago, Ill., June 13-15, 1927.

American Electric Company, Inc.
State and 64th Sts. Chicago, U. S. A.
Ask About BURNS B-Eliminator

Vee Dee

METAL CABINET and CHASSIS (SUB PANEL)
MADE SPECIALLY FOR THE

UNIVERSAL POWER PACK

as featured by
SILVER-MARSHALL
\$6.00 for the complete unit. Includes insulation bushings, washers and all necessary hardware and accessories

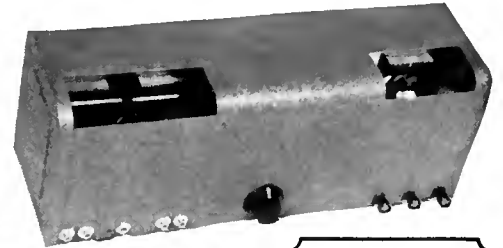

Bottom View



Made of Metal, beautifully finished in a rich neutral tone to harmonize with any radio cabinet. Chassis is completely and precisely drilled according to engineer's specifications. Truly, a most efficient housing for Silver-Marshall's Universal Power Pack. At your dealers' or direct from

THE VAN DOORN COMPANY
160 North La Salle Street Chicago, Illinois
FACTORY, QUINCY, ILLINOIS

Dealers carry Vee Dee metal panels in all standard stock sizes; panels for leading kits; adjustable sub-panels; Special Panel and Sub-Panel for the S. C. 2 Receiver.

Vee Dee Keeps Pace with the Latest and Best
WRITE FOR DETAILS

F. D. PITTS COMPANY

INCORPORATED

219-C Columbus Avenue, Boston, Mass., U. S. A.

"Pioneers in the Distribution of Radio"

DEALERS—Send for large and profusely illustrated catalog on the products of nationally advertised radio manufacturers.

Wholesale Exclusively

MERCHANDISING RADIO SINCE 1919



JEWELL

A
Quality
Instrument

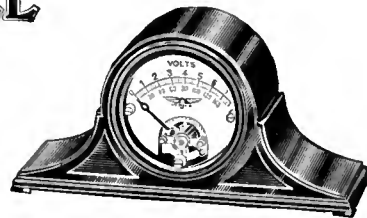

Pattern No.
135-C
Double Range
Voltmeter

Filament Control

Voltmeter Control of radio tube filament voltages—

- improves reception
- saves tubes
- preserves batteries
- gives additional satisfaction

Those are several real advantages.

Pattern No. 135-C high resistance portable voltmeter illustrated above is the choice of radio owners for measuring A, B and C battery and filament voltages. It operates on the D'Arsonval principle. Scale is silver etched with two special radio ranges in black characters. The pointer is equipped with a zero adjuster and the movement is assembled in a beautiful black bakelite case and furnished with a complete set of three phone tipped leads.

Write for special circular No. 1016.

Jewell Electrical Instrument Co.

1650 Walnut Street, Chicago

"27 Years Making Good Instruments"



What The New Sets Will Include!

More, even, than in previous years, Dongan Parts will be identified with the season's leading receivers and power units.

New designs in audio transformers and power unit parts are now available.

Manufacturers who are designing sets to use either the new Raytheon B A 350 m. a. Rectifier Tube or the Q. R. S. Full Wave 400 m. a. Gaseous Rectifier Tube can secure immediate delivery on Approved Transformers and Chokes.

Individual Set Builders



Transformer for Raytheon Tube
No. 3591
\$15 list
for Q. R. S. tube
No. 3581
\$15 list

Double Choke
(2 chokes in one case)
for either Raytheon Tube or Q. R. S. tube
No. 3584
\$15 list

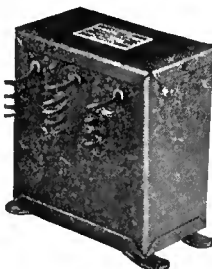

You can secure delivery at once by sending check or money order.

DONGAN ELECTRIC MFG. CO.
2991-3001 Franklin St., Detroit, Michigan



No. 107

RADIO BROADCAST Laboratory Information Sheet

July, 1927

Neutralization

EFFECTS OF MALADJUSTMENT

AT THE present time there is only one known way whereby a very high-gain high-frequency amplifier can be obtained, and that is by using several well-designed tuned radio-frequency amplifiers with each stage properly neutralized. Manufactured receivers are neutralized at the factory and consequently the problem of neutralizing a receiver or the effect of improper neutralization does not generally concern those who buy their receiver ready made. The home constructor, however, must neutralize his own receiver, and for this reason it is rather important that the effect of improper neutralization be known.

The first and most obvious manifestation of incorrect adjustment of the neutralizing device is oscillation in some or all of the radio-frequency circuits. These oscillations as a general rule become more severe as the frequency is increased, and a loud squeal or whistle will be heard as the tuning controls are adjusted to receive some station that is transmitting.

Such an effect will make it difficult for the user of the receiver to obtain satisfactory reception and the oscillations will be radiated from the antenna attached to the receiver and cause interference on other receivers located in the neighborhood. Such oscillations can be prevented by correct adjustment,

and it is essential that the proper setting be determined in order to make it possible to obtain best results from the receiver.

A second detrimental effect of maladjustment of the neutralizers is poor quality, which is generally due to the existence of too much regeneration. The quality under these conditions will generally sound drummy, indicating that the various frequencies in the carrier are being unequally amplified by the radio-frequency amplifiers. To preserve good quality, the radio-frequency amplifiers must amplify without distortion a band of frequencies extending about 5000 cycles above and 5000 cycles below the carrier frequency, and this condition does not exist unless proper neutralization is obtained.

Another effect of improper neutralization is to cause one or more of the tuned circuits in a single-control receiver to be thrown out of synchronism so that the set loses a great deal of its sensitivity, and as a result it is not possible to tune-in distant stations with satisfactory volume.

These three major effects of improper neutralization indicate how essential it is that neutralization be always carefully and completely accomplished. There are several satisfactory methods of neutralizing a receiver, and information regarding them can be found on Laboratory Sheet No. 38, published in the October, 1926, issue.

No. 108

RADIO BROADCAST Laboratory Information Sheet

July, 1927

High Voltage Supply for 210 Type Tube

THE DOUBLE TRANSFORMER METHOD

IF HIGH voltages up to 400 volts are required for operation of a 210 type power tube, it is generally best to use a B power unit incorporating a 216-B single-wave rectifier tube. This tube is capable of operating satisfactorily at the high transformer voltages which must be used. It is possible, however, by using a somewhat complicated arrangement, to obtain the high voltage by using low-voltage rectifiers such as the Raytheon and Q. R. S.

An arrangement whereby 400 to 450 volts can be obtained using two gaseous rectifiers is shown in the drawing on this Sheet. Two power transformers, T₁ and T₂, are necessary, each supplying about 220 volts each side of the center tap. They are connected into the circuit as shown and supply two rectifiers which in turn feed a common filter system. The maximum permissible current drain is 20 milliamperes using Raytheon type B tubes and 35 milliamperes using type BH tubes. Condensers C₁, C₂, C₃, and C₄ each have a capacity of 0.1 mfd.; C₅ and C₆ are of 2 mfd. capacity, and C₇, 8 mfd. All the condensers should have a working voltage of 750 volts d. c.

Filament current for the 210 tube should be obtained from a separate filament transformer

T₃ capable of supplying 1.25 amperes at 7.5 volts. The transformer should be tapped at the center as shown and a 1500-ohm resistance, R₁, connected between it and the negative B of the filter system. This resistance will supply C bias to the tube. Its bypass condenser should have a value of 2 mfd.

A 50,000- or 100,000-ohm resistance should be connected from B+ to B- if the unit is only to supply B potential to the 210, but if it is also to be used to supply B voltage to other tubes in a receiver the output should be shunted by several fixed resistors with taps at various points to obtain the desired voltages.

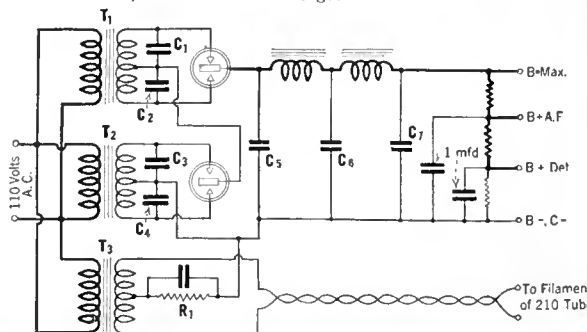

No. 109

RADIO BROADCAST Laboratory Information Sheet

July, 1927

The Threshold of Hearing and Feeling in the Ear

ENERGY REQUIRED FOR AUDIBILITY

A GREAT many important experiments in sound have been made in the various large laboratories. An interesting experiment is to determine how much energy is required by the ear in order to just hear tones of various frequencies between about 30 and 5000 cycles. Data of this sort can be plotted on a curve, a typical one being given on this Sheet. Such a curve is called a curve of "threshold audibility" because it indicates the amount of sound energy required to just produce an audible sound.

At 32 cycles a sound pressure of somewhat more than one dyne per square centimeter is required to produce an audible response, while at 2000 cycles only about 0.0003 dynes per square centimeter are required to produce an audible sound. The sound pressure required to produce a sound of minimum intensity is fairly constant between about 500 and 5000 cycles. Good speech articulation can be obtained within a frequency range of 250 and 2500 cycles; this band can, in fact, be narrowed to exclude all frequencies below 500 cycles and good articulation will still be retained. In the reproduction of music, however, it is necessary to include a much wider band having an upper limit of 5000 or 6000 cycles and a lower limit of about 32 cycles.

There is also an upper limit of sound pressure at which there is produced a sensation of feeling in the ear and it serves as a practical limit to the range of auditory sensation. At low frequencies the two curves of feeling and hearing meet each other, which indicates that these frequencies give a sensation

of feeling which is difficult to distinguish from a sensation of hearing.

The power in microwatts in each square centimeter of the sound wave under average conditions is related to the effective value of the pressure in dynes as follows:

$$\text{Power} = \frac{(\text{Pressure in Dynes})^2}{20.5}$$

Using this formula we can calculate the average power required to produce a minimum audible sound at frequencies between 2000 and 4000 cycles, which will be found to be about 4×10^{-10} microwatts per square centimeter.

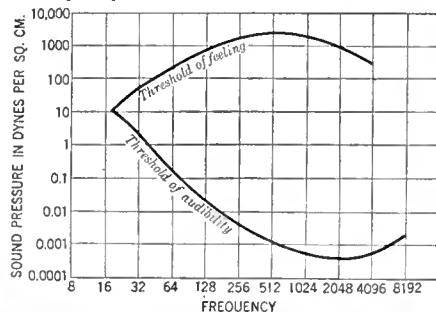

IN R.F. by-pass circuits

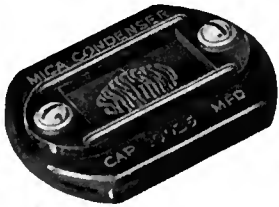

SANGAMO MICA CONDENSERS

A HIGH self inductance in condensers used in R. F. by-pass circuits means a loss in capacity at the lower wave lengths.

In many by-pass condensers the inductive reactance below 300 meters is appreciable. They become choke evils!

Use the larger capacities of Sangamo Mica Condensers in all R. F. circuits. Self inductance is negligible and direct current resistance more than 35,000-megohms! Sangamo Mica Condensers are all capacity.



SANGAMO ELECTRIC COMPANY
6136-2 SPRINGFIELD, ILLINOIS



At Booth 145 R. M. A. Show Chicago
June 13-18

RADIO FANS, a one-year's subscription to Radio Broadcast will cost you four dollars, two years six dollars. Consider this expenditure as being a necessary investment on your part for the future development of your own knowledge of Radio.

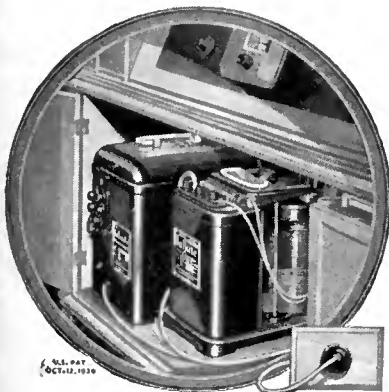

Convert your radio set into a light socket receiver with Balkite "B" and the Balkite Trickle and High-Rate Charger

Ask your radio dealer
FANSTEEL PRODUCTS CO., INC
North Chicago, Ill.

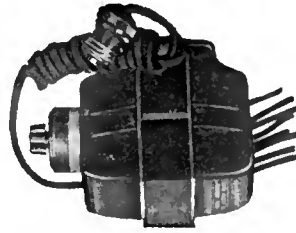

AmerTran DeLuxe audio transformers are guaranteed to amplify at 80% of their peak at 40 cycles, and their peak is above 10,000 cycles. Made for first and second stages, either type \$10.00.

The AmerTran power transformer type PF52, \$18.00, and the AmerChoke type 854, \$6.00, (illustrated) are designed for use in the construction of power amplifiers to operate with UX-216B and UX-210 tubes at their correct voltages, supplying A, B and C to the last audio, and B and C to the other tubes.

AMERTRAN RADIO PRODUCTS CARRY THIS GUARANTEE

"AmerTran audio transformers, regardless of type, are fully guaranteed against defects for a period of one year from the date of purchase, and will be replaced free of charge either through your authorized AmerTran dealer or direct, if defective for any cause other than misuse. The individual parts are each carefully tested and inspected before assembly and the complete transformer receives a most rigid inspection and test before being packed for shipment."

This is the way the American Transformer Company has won confidence and wide use for its products. AmerTran DeLuxe audio transformers are recognized as reliable, efficient units for improving the tone quality and tone range of present sets and as the indispen-

able choice for new sets. Other AmerTran products have been adopted for power supply apparatus that on performance stand in the front rank of modern development.

Send for booklet "Improving the Audio Amplifier," and other useful data, free.



The American Transformer Co.

178 EMMET STREET

NEWARK, N. J.

"Transformer Builders for Over 26 Years"

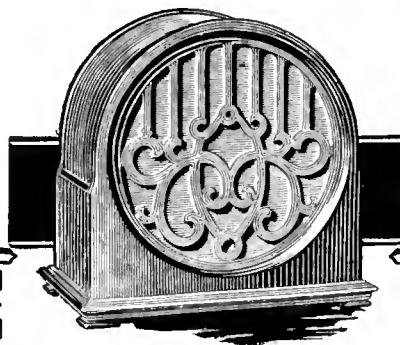

Amplion Cone

Cabinet Model AC12. . . \$30

“The reproducer is the most vital adjunct to a radio installation”

Yet nine people out of ten buy speakers without making any comparisons.

You will appreciate your Amplion even more after you have heard it in comparison with others.

Make a test!

If your dealer has no Amplion Cone in stock to give you a demonstration, write to us for the address of one who has.

Amplion has the most complete range of radio sound reproducers on the market. Models range all the way from \$12 to \$135 to fit every radio set and every purse.

THE AMPLION CORPORATION OF AMERICA

280 Madison Avenue
New York

The Amplion Corporation of Canada, Ltd., Toronto, Ont.



No. 110

RADIO BROADCAST Laboratory Information Sheet

July, 1927

Dry-Cell Tubes

BEST FILAMENT VOLTAGE

ALTHOUGH dry-cell tubes are generally operated with 3 volts on the filament, somewhat better results can be obtained if 3.3 volts is used instead.

The two solid curves on the accompanying diagram are obtained by measuring the plate current at various values of negative grid bias with 3.0 and then 3.3 volts across the filament. If the tube is functioning properly this curve will be a straight line over most of its length. The 3.0-volt curve slopes off at low values of grid bias and this indicates that the filament emission is too low and a signal would be distorted. The 3.3-volt curve, however, is straight over a large portion of its length and therefore this same tube with somewhat higher filament voltage is capable of amplifying without distortion.

The two dotted curves show the plate impedance of the tube first with 3.0 volts and then with 3.3 volts on the filament. With 3.0 volts, and therefore a low filament emission, we obtain an erratic plate impedance curve, which rises to values as high as 80,000 ohms at zero grid voltage. The plate impedance curve taken with 3.3 volts again indicates the value of using this voltage, for it shows the plate impedance to be comparatively constant and low over a greater part of its length, and this is as it should be.

This recommendation that 3.3 volts be used on the filament is the result of many tests made in the Laboratory, and the Cunningham Tube Company has also recommended that this voltage be used.

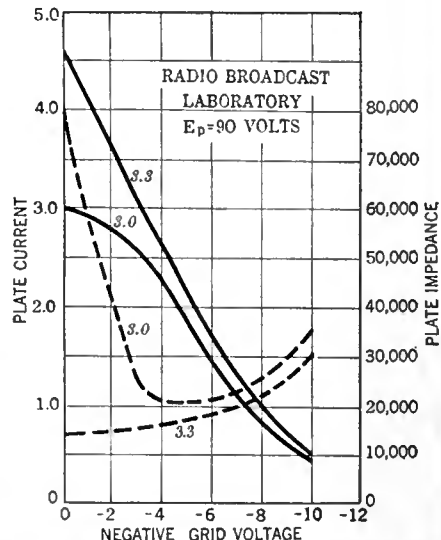

No. 111

RADIO BROADCAST Laboratory Information Sheet

July, 1927

Index

December, 1926, to July, 1927

SHEET NUMBER	MONTH	SHEET NUMBER	MONTH
Ampere, What It Is	78 March, 1927.	Detector, C-battery	54 December, 1926.
Audio Amplifying Systems		Ear, Threshold Sensitivity	109 July, 1927.
Double-Impedance		Electrons, Sources of	69 February, 1927.
Coupled	86, 87 April, 1927.	Filter Circuit Data	60 January, 1927.
Dual-Impedance		Frequency Ranges of	
Coupled	93 May, 1927.	Musical Instruments	52 December, 1926.
Push-Pull Amplification		Harmonics	
Resistance-Coupled	71 February, 1927.	What They Are	59 January, 1927.
Transformer-Coupled	74 March, 1927.	Importance of	51 December, 1926.
Amplification Constants,	98 June, 1927.	Interference	
Calculation of	88 April, 1927.	Elimination	77 March, 1927.
Amplifying Systems,	80 March, 1927.	Finder	75, 76 March, 1927.
Efficiency of	102 June, 1927.	Intermediate-Frequency	
Antenna		Amplifier	61 January, 1927.
Loop	90 May, 1927.	Lightning Arrestors	101 June, 1927.
Power Dissipation	62 January, 1927.	Line Power-Supply	
Tuning the Antenna	55 December, 1926.	Devices	63 January, 1927.
Arc, The	97 June, 1927.	Loop Antennas	90 May, 1927.
Audio Transformers	103 June, 1927.	Musical Instruments,	
Batteries, Storage	95 May, 1927.	The Frequency Range	52 December, 1926.
C Voltages	85 April, 1927.	of	
Chargers, Trickle	49 December, 1926.	Mutual Conductance,	
Coils, Short-Wave	89 May, 1927.	Calculation of	83 April, 1927.
Coils, Measuring Radio-		Neutralization, Importance	
Frequency Resistance	105 July, 1927.	of	107 July, 1927.
Condensers, Gang	64 January, 1927.	Ohm's Law	81 April, 1927.
		Ohm, What It Is	78 March, 1927.

No. 112

RADIO BROADCAST Laboratory Information Sheet

July, 1927

Index

December, 1926, to July, 1927

SHEET NUMBER	MONTH	SHEET NUMBER	MONTH
Oscillation Control	82 April, 1927.	Short Wave Coils	89 May, 1927.
Oscillator, Radio Frequency	66 February, 1927.	Shunts	53 December, 1926.
Overtones (Harmonics)	51 December, 1926.	Soldering	70 February, 1927.
Plate Impedance, How It Is Calculated	67 February, 1927.	Storage Batteries	95 May, 1927.
Power Amplifier, A. C. Operated	73 March, 1927.	Transformer Coupled Amplifiers	88 April, 1927.
Power-Supply Devices		Transformers, Audio	103 June, 1927.
Calculation of Resistance Values	63 January, 1927.	Trickle Chargers	49 December, 1926.
High Voltage Unit for 210	000 July, 1927.	Tubes	
Output Curves	104 June, 1927.	Characteristics General	80 March, 1927.
Regulating Voltage	79 March, 1927.	Characteristics, 240	106 July, 1927.
Trouble Shooting	72 February, 1927.	Characteristic Curves, 120	84 April, 1927.
Push-pull Amplification	71 February, 1927.	Comparison of 171 and 210	58 January, 1927.
Radio Telegraph Transmission	56 December, 1926.	Curves for the 171	68 February, 1927.
Receivers		Filament Voltage, Dry Cell Tubes	110 July, 1927.
Portable	75, 76 March, 1927.	Hard and Soft Tubes	50 December, 1926.
"Universal"	99, 100 June, 1927.	171 Characteristics	67, 68 February, 1927.
Reflexing, The Principle of	94 May, 1927.	Tube Tester	91, 92 May, 1927.
Regulating Voltage on B Power-Supply Device	79 March, 1927.	Tuning the Antenna Circuit	55 December, 1926.
Resistance-Coupled Amplifiers	74 March, 1927.	"Universal" Receiver	99, 100 June, 1927.
Resonance, What It Is	57 January, 1927.	Vacuum-Tube Voltmeter	65 February, 1927.
		Voice Frequencies, Analysis of	96 May, 1927.
		Volt, What It Is	78 March, 1927.

Announcement

The Abox

Complete "A" BATTERY Eliminator

Now Available

NOTHING ELSE TO BUY

Licensed by the ANDREWS-HAMMOND CORP., under Andrews' condenser and other Andrews and Hammond Patents and Patent applications.



SIZE
9 7/8" long
8 3/4" high
5 5/8" wide

The Best and Cheapest "A" Power

The Abox "A" Eliminator is a rectifier and an Abox Filter circuit in one compact unit. It changes the alternating current from the light socket to hum-free direct current for operating eight or less large tubes at 6 volts. Simply connect to any radio set without changing the wiring and turn the switch at the light socket.

It contains no batteries in paste form or otherwise. The same *condensers* that proved their efficacy in the Abox Filter are used in the Abox "A" Eliminator and supply the enormous capacities needed for a low voltage filter. These condensers cannot be punctured or broken down—they do not need replacing and their characteristics do not change with use or disuse.

The Abox will give the same long life and the same 100% customer satisfaction that the many thousands of Abox Filters now in use throughout the country have given in the past. It is fully guaranteed for one year from the date purchased by the customer.

Each part of the Abox "A" Eliminator is carefully designed and has been tested over long periods. Together they form a perfectly co-ordinated unit which is not only the *best* but the *cheapest* source of "A" Power for radio sets.

We will be pleased to furnish detailed information. Send for circulars or see us at the Abox booth and demonstration rooms at the RMA Trade Show, Chicago.

The Abox Company

215 North Michigan Avenue, Chicago, Illinois

RADIO TESTING

MODEL 519 Radio Set Tester short-cuts testing time and makes it simpler. This tester can be used to run down trouble on any set operated on battery or battery eliminator. No auxiliary batteries required other than those in the set. Test all voltages at tube sockets or at battery terminals. Test tubes and circuit condition and continuity.

For full information address



WESTON ELECTRICAL
INSTRUMENT CORPORATION

179 Weston Avenue, Newark, N. J.



Equipment for the Home-Constructor

How to Use Some of the New and Interesting Radio Equipment Which the Market Offers

By THE LABORATORY STAFF

TAYLOR RESONANCE INDICATOR

THE design of a receiver in which several of the tuning condensers are actuated by a single control is a somewhat difficult job because it is essential that each of the tuned circuits be in exact resonance with each other to prevent loss in selectivity and sensitivity.

The coils and condensers used in such a receiver must be as electrically similar as possible, and it is generally advisable to check each coil-condenser combination separately to make certain that it tunes, throughout the entire frequency range of the receiver, exactly the same as the other tuned circuits. A simple and satisfactory method of making a test of this sort is possible with the use of the new Taylor resonance indicator, shown in a photograph on this page.

The circuit diagram is given in Fig. 1. Two 201-A type tubes are necessary to operate the

which corresponds to 17 on the dial (See Fig. 2), and then turn the instrument on. The oscillations in tube A are fed through the small coupling condenser, C_2 , to the tuned circuit of the receiver to which the leads are connected, and as a result, a voltage will be developed across the tuned circuit. This voltage will be a maximum when the tuned circuit in the receiver is in exact resonance with

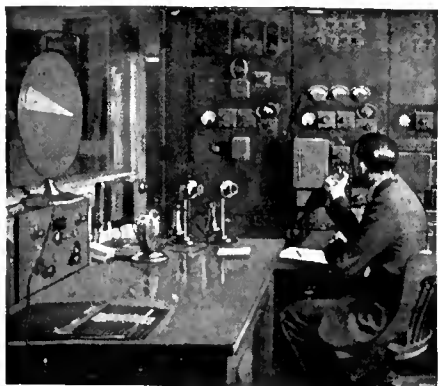

Would You Like To Earn More Money-in Work That's Almost Romance?

Then be a RADIO EXPERT!



J. E. SMITH, President

If you're earning a penny less than \$50 a week, clip coupon below. Get my big Free Book telling about opportunities for big money in Radio, Television, trans-Atlantic Radio telephony, many other wonderful inventions and developments constantly creating big new Radio opportunities. Here's work that's almost romance, a NEW, speedy, growing, live-wire profession.

And Radio needs trained men! Salaries from \$50 all the way up to \$250 a week are not unusual. You can easily learn Radio for bigger pay by my tested, practical methods. Hundreds of men have already done it. You learn quickly in your spare hours AT HOME—it's all so interesting to you that it's easy!

Extra Dollars for You Almost At Once

Think of making \$15, \$20, \$30, extra every week "on the side," without interfering with your regular job! I'll teach you to do it almost at once after you start your Radio training with me, by using spare time that you're wasting now. And all the while you'll be getting ready for the bigger Radio jobs ahead.

You can easily pay for your course and put money in the bank while learning, when you learn by my practical methods. And you don't need to leave home, or interfere with the job you have now, while you're doing it! Fill out and mail the coupon below for the big book of Facts and Proof.

64-Page Book Sent Free

When I receive your coupon I'll mail you my big 64-page Book immediately. It's filled with photos and facts about the opportunities in Radio, and tells how you can prepare, quickly and easily, in your spare time at home, to be an expert in this field. No previous Radio experience needed to take advantage of this offer. No special schooling required. Mail coupon now, address: J. E. Smith, President.

Six Big Outfits of Practice Material Given Free of Extra Cost

With your training you get free of extra cost 6 great outfits of real Radio practice material. With these 6 outfits you can build 100 real Radio circuits. This is the practical kind of home-training. You learn to hold a job—not on paper... ON THE PAY-ROLL. Send coupon below for details of this offer.



J. E. SMITH, President
National Radio Institute
Dept. G-94, Washington, D. C.

Dear Mr. Smith: Kindly send me your 64-page Free Book which tells about learning Radio for bigger pay. Also send information on your offer of 6 outfits of material free of extra cost. I understand this places me under no obligation.

Name
Address
Town State



THE TAYLOR RESONANCE INDICATOR

device. One of them is placed in socket A and acts as an oscillator, the oscillatory circuit consisting of C_1 , L_1 , and L_2 ; the frequency range of the oscillator is 500 to 1500 kc. The other tube is placed in socket B, and it acts as a rectifier of the current flowing through the galvanometer, "G." In the following paragraphs we will describe the procedure in testing a single-control receiver for synchronism.

Suppose that we have such a receiver consisting of three tuned circuits A, B, and C, all of them operated from a single dial. If the receiver is to give satisfaction these three circuits must tune to exactly the same frequency at exactly the same point, and the problem is to determine if such is the case. In making the test no batteries at all should be connected to the receiver. The resonance indicator itself, however, requires for its operation a 45-volt B battery and a 6-volt storage battery for filament supply.

There are two leads attached to the resonance indicator, one red, the other green, and these leads should be connected, respectively, to the stator and rotor of the first variable condenser in the receiver. Now set the dial on condenser C_1 at some medium frequency, say 1000 kilocycles,

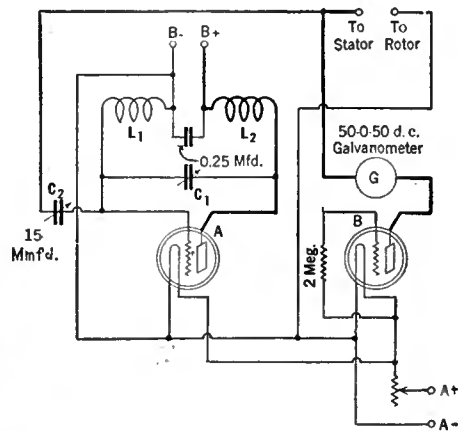

FIG. 1

the oscillations produced by tube A. This voltage across the tuned circuit, will cause a current to flow through the galvanometer and the tube B connected in series with it, and the current flowing through the galvanometer will be proportional to the voltage. It is evident that maximum galvanometer deflection means maximum voltage and, therefore, that the circuit is in resonance. The dial reading of the receiver at resonance should be noted down as accurately as possible.

Without in any way changing any of the settings on the resonance indicator, the two connections are moved over to the next stage in the receiver and connected to circuit B. The condenser in this circuit is then adjusted for maximum deflection as was done with the condenser

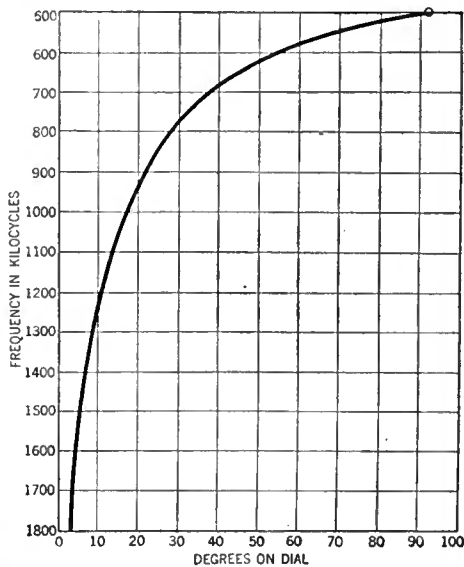

FIG. 2

Goodrich



Radio Panels

Black, Mahogany and Walnut.
Standard thickness 3-16" and 1/4".
High softening point prevents warping.

Low free sulphur content prevents discoloration.

Machine easier and are better electrically than any other material in common use.

Your radio dealer has them or will get them for you—if not, write to us and we will see that you are supplied.

Also hard rubber for coils, spaghetti tubing and miscellaneous rubber items for radio manufacturers.

Radio Sales Division

The B. F. Goodrich Rubber Company
Established 1870 Akron, Ohio

SILVER-MARSHALL UNIPAC \$62.

Wholesale Headquarters

FREE New 1927 Catalog FREE

Shows photographs and hook-ups of all latest kits, complete line of cabinets and consoles, accessories and parts. We are headquarters for all nationally advertised lines. Dealers and professional set builders write on your letterhead today for your copy of this big FREE CATALOG.

SHURE RADIO CO., 333 N-335 W. Madison St., CHICAGO, ILL.

Why not subscribe to *Radio Broadcast*? By the year only \$4.00; or two years, \$6.00, saving \$2.40. Send direct to Doubleday, Page & Company, Garden City, New York.

The NEW and wonderfully improved AERO COIL

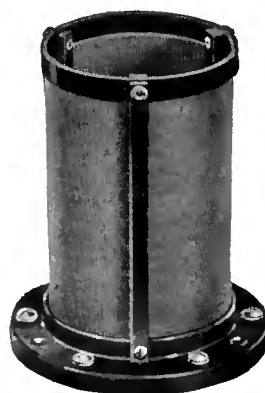

Perfectly
Matched

Adaptable to all
Standard Tubes

The supersensitive AERO coil has been improved! Always renowned for its selectivity, power, and sensitivity, the AERO coil is destined to win even greater favor in its new form. This new coil is the very last word in inductance coil construction. It contains a host of new and exclusive features. It possesses amazing adaptability and can be used in all R. F. circuits—both bridge and loss balanced. What's more it is easily adaptable to 5, 6, or 7 tube sets!

Here are other sensational features of this new and improved AERO coil:

1. **Rugged**—Will keep appearance and original electrical characteristics indefinitely.
2. **High electrical efficiency**—Unusually high ratio of inductance to radio frequency resistance.
3. **Shape ratio**—Ratio of coil length to coil diameter is such that magnetic coupling between coils is at a minimum, thus eliminating necessity for shielding in many receivers.
4. **Good mounting facilities**—Terminals at lower end of coil permit short connection to tubes, sockets, etc.
5. **Adaptability**—Carefully designed primary windings of proper impedance for any type commercial tube immediately available.
6. **Ease of connection**—Screw type terminals permit optional choice of connections without soldering iron, or with soldering iron.

The new AERO coils will be shown for the first time at our exhibition in Booth 12, at the R. M. A. Trade Show. They will be available at your dealers after July 1. You can get them in 3 coil kits, with refinement, at \$12.00. 4 coil kit, with refinement, \$16.00. These new coils will also be used in the AERO R. F. R. Kit and the AERO 3 Circuit Tuner.

AERO PRODUCTS, Inc.

Dept. 109 1772 Wilson Ave., Chicago, Ill.



Most from Your Tubes



GOOD tubes are little better than poor tubes without Amperite. Utmost performance and longest life requires the perfect automatic filament control of each individual tube, afforded only by Amperite. Insist on this variable filament resistance—and look for the name. Eliminates hand rheostats. Simplifies wiring.

Radiall Book—FREE

Explains fully Amperite principle and operation. Gives season's best Hook-Ups and Construction Data. Send for it today to Dept. RB35

Radiall Co., 50 Franklin St., New York



Price \$1.10
mounted (U.S.A.)
Sold Everywhere

AMPERITE

REG. U.S. PAT. OFF.
The "SELF-ADJUSTING" Rheostat

TO RADIO DEALERS!

The R. B. Laboratory Information Sheets have been appearing in RADIO BROADCAST since June, 1926. They are a regular feature in each issue and they cover a wide range of information of value to the radio experimenter and set builder. We have just reprinted Lab. Sheets Nos. 1-88 from the June, 1926, to April, 1927, issues of RADIO BROADCAST. They are arranged in numerical order and are bound with a suitable cover. They sell at retail for one dollar a set. Write for dealers' prices. Address your letter to

Circulation Dept., RADIO BROADCAST, Garden City, N. Y.

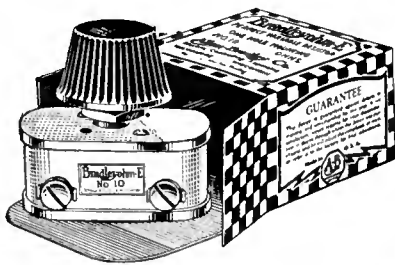

Bradleyohm-E

PERFECT VARIABLE RESISTOR

THIS oversize variable resistor is used as standard equipment for accurate plate voltage adjustment in B-eliminators made by the leading manufacturers of the country. The scientifically treated discs provide stepless, noiseless plate voltage control, and the setting will be maintained indefinitely.

Bradleyohm-E is made in several ranges and capacities to suit any radio circuit.

Send for Free Folder giving 7 B-eliminator hook-ups

Mail the coupon below for folder describing 7 hook-ups for B-eliminators using well-known kits and parts.

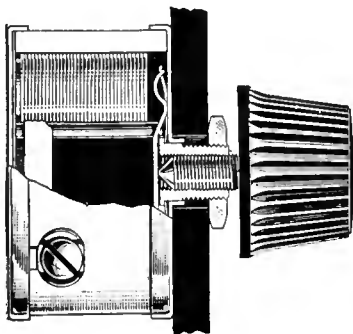

Ask your dealer to include Bradleyohm-E and Bradleyunit-A for variable and fixed resistance units when you build your B-eliminator.

Mail this coupon to

ALLEN-BRADLEY CO.
278 Greenfield Ave., Milwaukee, Wis.

Please send me your folder giving 7 B-eliminator hook-ups, and also data on all Allen-Bradley radio devices.

Name.....

Address.....

in circuit A, and the dial reading noted. The same test is then made with the leads connected across the condenser in tuned circuit C. If it is found that the dial on the receiver must be tuned to exactly the same point in all three cases, we have a good indication that the three circuits are in synchronism. If, on the other hand, one of the condensers gives a different reading than the other two it must be readjusted so as to give exactly the same reading.

Usually only one test for alignment is necessary at some medium frequency. The set may be checked at three or more points if it is deemed necessary, by simply placing the condenser dial of the tester at a different setting and repeating the test outlined above. A precaution which must be observed is to keep the leads from the oscillator to the receiver well separated and well away from metallic parts, otherwise untrue results will be experienced. This is particularly true with short wavelength (high-frequency) readings.

This tester may also be used as a source of high-frequency oscillations for many different tests by simply attaching a short piece of wire to the "stator" binding post for an antenna and connecting the "rotor" binding post to ground. Manufactured by the Taylor Electric Company, Madison, Wisconsin. Price \$32.50.

RADIO SET TESTER

WHEN a service man or a radio experimenter has to diagnose trouble in a radio receiver, he needs certain instruments and meters for the purpose. If these instruments and meters are individual pieces of apparatus, he will need a number of them. They are bulky and a good deal of time is wasted in making connections. The new Weston No. 519 set tester gives a combination of instruments in a compact form, which permits of easy operation and a considerable saving of time. All routine tests can be made on sets, tubes, and other accessories, with very little effort and a minimum number of connections.

Only one meter is used in the test kit, as shown in the accompanying photograph. This one meter, however, by means of an ingenious switch and a combination of meter scales, can be made to read A, B, and C voltages, and plate current, besides being able to check open or closed circuits. For testing tubes a socket is provided, and connections are made directly to the set by means of a cable and a plug arrangement which, by means of adapters, can be plugged into any type socket in the receiving set.

By simply placing the plug in one of the receiver sockets and manipulating the switch, all of the A, B, and C voltages may be read. This switch is of the double-contact type; that is, for each connection, both sides of the line are opened or closed, as the case may be. This prevents interconnections which might possibly cause some trouble. The switch is marked in the following manner:

(1) "OPEN." The meter is entirely disconnected from the cable or binding posts and is in the starting position.

(2) "VM. B.P." There are three binding posts at the right-hand side. With the switch in this position the meter is not connected with the cable but may be used by placing leads on the binding posts. By connecting between the minus binding post and the center one of the three, voltages up to 8 may be measured, while, by connecting between the minus post and the top one, voltages up to 200 may be read, thus giving the operator a simple double-range voltmeter.

(3) "C A-REV." This point on the switch gives the C-battery voltage (with plug in receiver) on a reversed socket. Some receivers have the filament connections on the socket reversed. While this condition does not affect the operation of the receiver it would make the d.c. meter read backward unless provision was made for it. The voltage as read on the 8-volt scale should be multiplied by 10.

(4) "C." This point on the switch gives the C-voltage reading when the socket is connected in the standard manner.

(5) "B." This point gives the voltage of the B battery at the socket and is read on the 200-volt scale.

(6) "PLATE MA." With a tube inserted in the socket of the tester and the cable connected to the receiver, the meter will read the plate current taken by the tube on the 200-volt scale. The reading on this scale should be divided by 10. That is, if the meter read 80, it would really indicate 8 mA.

(7) "A." This point on the switch connects the meter to the filament connections on the socket and gives A voltage on the 8-volt scale.

(8) "A-REV." Gives the A voltage if the socket happens to be reversed as mentioned above.

(9) "OPEN." This is the same as the "open" position in No. 1. The switch may be placed in either No. 1 or No. 9 position thus making it immaterial in which direction the switch is turned in starting a test.

In making tests, the plug is placed in one of the sockets of the receiver, the rest of the tubes remaining in their respective places. The batteries are left connected. The switch is then manipulated and the A, B, and C battery voltages read. If no reading is obtained, an open circuit is indicated. The tube may then be placed in the tester socket and its plate current determined.

A simple test is provided for tubes. A small button at the center bottom of the test panel is pressed. This places a zero grid bias on the tube. The difference in plate current reading with the button up or down indicates the worth of the tube. The difference can be compared directly with a table accompanying the tester.

All in all, any test on tubes, batteries, or receivers can be made quickly and definitely without loss of time with this instrument and it should recommend itself strongly to those who have to handle radio receivers in trouble. Manufactured by the Weston Electrical Instrument Corporation, of Newark, New Jersey. Price \$75.00



RADIO BROADCAST Photograph

WESTON RADIO SET TESTER

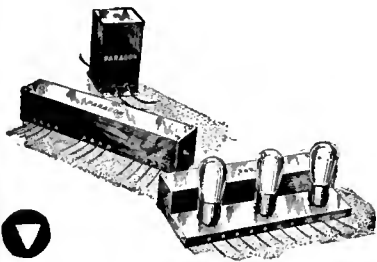

PARAGON

Double Impedance
Amplification System

PARAGON

Output Filters

PARAGON

Socket Power
Radio Receivers



Write for Information.

Paragon Electric Corporation

Upper Montclair

New Jersey

GROW TALLER



Science has found the way to add inches to your height. No need to envy and look up to the big fellows. No need to have the disadvantages of the little man. This course makes it possible for you to be on a level with your fellow men. Course is easy, inexpensive and results sure. Mail coupon for free information to-day!

L. GLOVER
 Room 42, 70 Bulkley Ave.
 Sausalito, Calif.
 Without any obligation to me, send me full information on how to grow taller.
 Name
 Street
 City

Order your copy of *Radio Broadcast* from your news dealer or radio store. Make sure that he reserves a copy for you each month. If your favorite radio store does not stock the magazine write us giving name of radio dealer and address.

To prevent R. F. Current from going astray

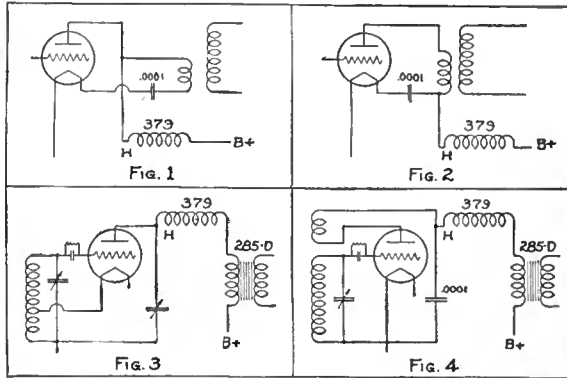

Type 379
Radio Frequency Choke
Price \$2.00

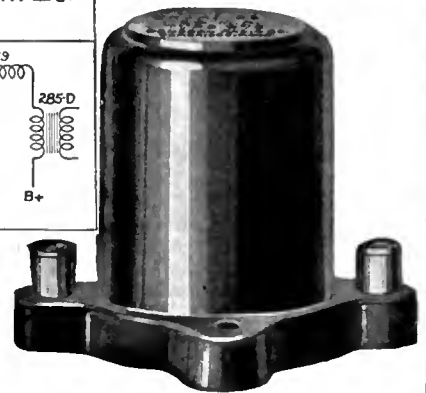

The figures in the above diagram show the more common uses for the Type 379 Radio Frequency Choke.

In many of the popular receiving and transmitting circuits, a radio frequency choke is recommended.

A choke is necessary wherever a parallel plate circuit is used in order to prevent the plate supply circuit forming a shunt for radio frequency current, and is of material assistance in reducing coupling between stages using a common plate supply.

The Type 379 Radio Frequency Choke has a high impedance over the entire broadcast and amateur wavelength range. It has an inductance of 60 millihenries and maintains an effective capacity of not more than 4 MMF between 20 and 640 meters.

Type 379 R. F. Choke Price \$2.00

GENERAL RADIO CO.

Cambridge, Mass.

GENERAL RADIO

PARTS and ACCESSORIES

The General Radio Company has endeavored to make it possible for the experimenter to obtain its products with minimum of effort. A careful selection of distributors and dealers has been made. They are best suited to serve you. If, however, you are unable to obtain our products in your particular locality, they will be delivered to you, postpaid, direct from the factory upon receipt of list price.

Fahnestock Clips

RADIO'S GREATEST CONVENIENCE

Used by Manufacturers of Standard Sets and Parts—and by Manufacturers of High Grade Wet and Dry Batteries.

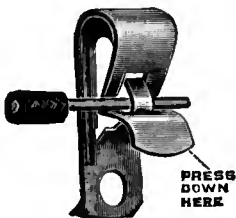

PRESS DOWN HERE

ALL GENUINE
FAHNESTOCK CLIPS

bear our imprint on the thumb piece of the clip.

WORLD'S LARGEST MAKER OF CLIP TERMINALS

48 different sizes and styles to meet all requirements.

Send for Catalog and Samples

FAHNESTOCK ELECT. CO.
L. I. City New York

\$12 For the FENCO GIANT SPEAKER 3ft.

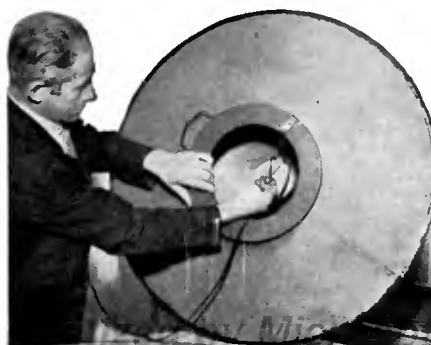

No sound, high or low, is outside the range of this giant cone speaker. Its soft, mellow, and brilliant reproduction brings a new thrill to radio.

\$12 for Complete Outfit--Build It Yourself

Everything necessary supplied and every part of the highest quality. Only a screw driver, scissors, and thirty minutes of your time needed. Nothing else to buy and nothing left to desire in the way of true reproduction. Satisfied and delighted customers write us—"Better than my neighbor's \$70 speaker." "As different from any other speaker as a first orchestra seat is from one in the gallery." "I'm a dub at building but your plan of printing directions where they can be seen enabled me to build the speaker in nearly record time and I'm more than pleased with it."

Direct from Factory to You

Let your family listen to real radio. Order now for immediate shipment. Satisfaction guaranteed or money cheerfully refunded.

FENCO CONE COMPANY
57½ Murray St., New York City

ASK . . ANY . . RADIO . . ENGINEER



This is the Burgess Radio "A" Battery

A SPECIALLY designed "A" battery for radio service. There is nothing like it in its field.

Proportioned to permit ease of handling and convenience of cabinet assembly and storage, you may expect this new Burgess creation to give you the length of service and dependability under all conditions for which all products of Burgess are noted.

If you are using the ordinary type of No. 6 "A" battery, we suggest that you learn for yourself from the Burgess Radio "A" the measure of service you have a right to expect.

Ask Any Radio Engineer

BURGESS BATTERY COMPANY
GENERAL SALES OFFICE: CHICAGO

Canadian Factories and Offices:
Niagara Falls and Winnipeg

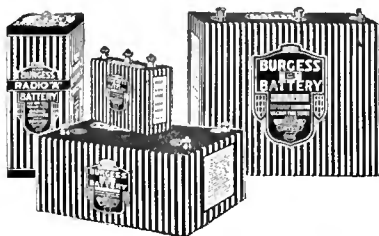

BURGESS RADIO BATTERIES

Manufacturers' Booklets

A Varied List of Books Pertaining to Radio and Allied Subjects Obtainable Free With the Accompanying Coupon

READERS may obtain any of the booklets listed below by using the coupon printed on page 188. Order by number only.

1. FILAMENT CONTROL—Problems of filament supply, voltage regulation, and effect on various circuits. RADIALL COMPANY.
2. HARD RUBBER PANELS—Characteristics and properties of hard rubber as used in radio, with suggestions on how to "work" it. B. F. GOODRICH RUBBER COMPANY.
3. TRANSFORMERS—A booklet giving data on input and output transformers. PACENT ELECTRIC COMPANY.
4. RESISTANCE-COUPLED AMPLIFIERS—A general discussion of resistance coupling with curves and circuit diagrams. COLE RADIO MANUFACTURING COMPANY.
5. CARBORUNDUM IN RADIO—A book giving pertinent data on the crystal as used for detection, with hook-ups, and a section giving information on the use of resistors. THE CARBORUNDUM COMPANY.
6. B-ELIMINATOR CONSTRUCTION—Constructional data on how to build. AMERICAN ELECTRIC COMPANY.
7. TRANSFORMER AND CHOKE-COUPLED AMPLIFICATION—Circuit diagrams and discussion. ALL-AMERICAN RADIO CORPORATION.
8. RESISTANCE UNITS—A data sheet of resistance units and their application. WARN-LEONARD ELECTRIC COMPANY.
9. VOLUME CONTROL—A leaflet showing circuits for distortionless control of volume. CENTRAL RADIO LABORATORIES.
10. VARIABLE RESISTANCE—As used in various circuits. CENTRAL RADIO LABORATORIES.
11. RESISTANCE COUPLING—Resistors and their application to audio amplification, with circuit diagrams. DEJUR PRODUCTS COMPANY.
12. DISTORTION AND WHAT CAUSES IT—Hook-ups of resistance-coupled amplifiers with standard circuits. ALLEN-BRADLEY COMPANY.
15. B-ELIMINATOR AND POWER AMPLIFIER—Instructions for assembly and operation using Raytheon tube. GENERAL RADIO COMPANY.
- 15A. B-ELIMINATOR AND POWER AMPLIFIER—Instructions for assembly and operation using an R. C. A. rectifier. GENERAL RADIO COMPANY.
16. VARIABLE CONDENSERS—A description of the functions and characteristics of variable condensers with curves and specifications for their application to complete receivers. ALLEN D. CARDWELL MANUFACTURING COMPANY.
17. BAKELITE—A description of various uses of bakelite in radio, its manufacture, and its properties. BAKELITE CORPORATION.
19. POWER SUPPLY—A discussion on power supply with particular reference to lamp-socket operation. Theory and constructional data for building power supply devices. ACME APPARATUS COMPANY.
20. AUDIO AMPLIFICATION—A booklet containing data on audio amplification together with hints for the constructor. ALL AMERICAN RADIO CORPORATION.
21. HIGH-FREQUENCY DRIVER AND SHORT-WAVE WAVE-METER—Constructional data and application. BURGESS BATTERY COMPANY.
46. AUDIO-FREQUENCY CHOKES—A pamphlet showing positions in the circuit where audio-frequency chokes may be used. SAMSON ELECTRIC COMPANY.
47. RADIO-FREQUENCY CHOKES—Circuit diagrams illustrating the use of chokes to keep out radio-frequency currents from definite points. SAMSON ELECTRIC COMPANY.
48. TRANSFORMER AND IMPEDANCE DATA—Tables giving the mechanical and electrical characteristics of transformers and impedances, together with a short description of their use in the circuit. SAMSON ELECTRIC COMPANY.
49. BYPASS CONDENSERS—A description of the manufacture of bypass and filter condensers. LESLIE F. MUTER COMPANY.
50. AUDIO MANUAL—Fifty questions which are often asked regarding audio amplification, and their answers. AMERITRAN SALES COMPANY, INCORPORATED.
51. SHORT-WAVE RECEIVER—Constructional data on a receiver which, by the substitution of various coils, may be made to tune from a frequency of 16,660 kc. (18 meters) to 1990 kc. (150 meters). SILVER-MARSHALL, INCORPORATED.
52. AUDIO QUALITY—A booklet dealing with audio-frequency amplification of various kinds and the application to well-known circuits. SILVER-MARSHALL, INCORPORATED.
56. VARIABLE CONDENSERS—A bulletin giving an analysis of various condensers together with their characteristics. GENERAL RADIO COMPANY.
57. FILTER DATA—Facts about the filtering of direct current supplied by means of motor-generator outfits used with transmitters. ELECTRIC SPECIALTY COMPANY.
59. RESISTANCE COUPLING—A booklet giving some general information on the subject of radio and the application of resistors to a circuit. DAVEN RADIO CORPORATION.
60. RESISTORS—A pamphlet giving some technical data on resistors which are capable of dissipating considerable energy; also data on the ordinary resistors used in resistance-coupled amplification. THE CRESCENT RADIO SUPPLY COMPANY.
62. RADIO-FREQUENCY AMPLIFICATION—Constructional details of a five-tube receiver using a special design of radio-frequency transformer. CAMFIELD RADIO MANUFACTURING COMPANY.
63. FIVE-TUBE RECEIVER—Constructional data on building a receiver. AERO PRODUCTS, INCORPORATED.
64. AMPLIFICATION WITHOUT DISTORTION—Data and curves illustrating the use of various methods of amplification. ACME APPARATUS COMPANY.
65. RADIO HANDBOOK—A helpful booklet on the functions, selection, and use of radio apparatus for better reception. BENJAMIN ELECTRIC MANUFACTURING COMPANY.
66. SUPER-HETERODYNE—Constructional details of a seven-tube set. G. C. EVANS COMPANY.
70. IMPROVING THE AUDIO AMPLIFIER—Data on the characteristics of audio transformers, with a circuit diagram showing where chokes, resistors, and condensers can be used. AMERICAN TRANSFORMER COMPANY.

71. DISTORTIONLESS AMPLIFICATION—A discussion of the resistance-coupled amplifier used in conjunction with a transformer, impedance, or resistance input stage. Amplifier circuit diagrams and constants are given in detail for the constructor. AMSCO PRODUCTS INCORPORATED.
72. PLATE SUPPLY SYSTEM—A wiring diagram and layout plan for a plate supply system to be used with a power amplifier. Complete directions for wiring are given. AMERITRAN SALES COMPANY.
80. FIVE-TUBE RECEIVER—Data are given for the construction of a five-tube tuned radio-frequency receiver. Complete instructions, list of parts, circuit diagram, and template are given. ALL-AMERICAN RADIO CORPORATION.
81. BETTER TUNING—A booklet giving much general information on the subject of radio reception with specific illustrations. Primarily for the non-technical home constructor. BREMER-TULLY MANUFACTURING COMPANY.
82. SIX-TUBE RECEIVER—A booklet containing photographs, instructions, and diagrams for building a six-tube shielded receiver. SILVER-MARSHALL, INCORPORATED.
83. SOCKET POWER DEVICE—A list of parts, diagrams, and templates for the construction and assembly of socket power devices. JEFFERSON ELECTRIC MANUFACTURING COMPANY.
84. FIVE-TUBE EQUAMATIC—Panel layout, circuit diagrams, and instructions for building a five-tube receiver, together with data on the operation of tuned radio-frequency transformers of special design. KARAS ELECTRIC COMPANY.
85. FILTER—Data on a high-capacity electrolytic condenser used in filter circuits in connection with A socket power supply units, are given in a pamphlet. THE ABOX COMPANY.
86. SHORT-WAVE RECEIVER—A booklet containing data on a short-wave receiver as constructed for experimental purposes. THE ALLEN D. CARDWELL MANUFACTURING CORPORATION.
88. SUPER-HETERODYNE CONSTRUCTION—A booklet giving full instructions, together with a blue print and necessary data, for building an eight-tube receiver. THE GEORGE W. WALKER COMPANY.
89. SHORT-WAVE TRANSMITTER—Data and blue prints are given on the construction of a short-wave transmitter, together with operating instructions, methods of keying, and other pertinent data. RADIO ENGINEERING LABORATORIES.
90. IMPEDANCE AMPLIFICATION—The theory and practice of a special type of dual-impedance audio amplification are given. ALDEN MANUFACTURING COMPANY.
93. B-SOCKET POWER—A booklet giving constructional details of a socket-power device using either the BH or 313 type rectifier. NATIONAL COMPANY, INCORPORATED.
94. POWER AMPLIFIER—Constructional data and wiring diagrams of a power amplifier combined with a B-supply unit are given. NATIONAL COMPANY, INCORPORATED.

ACCESSORIES

22. A PRIMER OF ELECTRICITY—Fundamentals of electricity with special reference to the application of dry cells to radio and other uses. Constructional data on buzzers, automatic switches, alarms, etc. NATIONAL CARBON COMPANY.
23. AUTOMATIC RELAY CONNECTIONS—A data sheet showing how a relay may be used to control A and B circuits. YAKLEY MANUFACTURING COMPANY.
25. ELECTROLYTIC RECTIFIER—Technical data on a new type of rectifier with operating curves. KODEL RADIO CORPORATION.
26. DRY CELLS FOR TRANSMITTERS—Actual tests given, well illustrated with curves showing exactly what may be expected of this type of B power. BURGESS BATTERY COMPANY.
27. DRY-CELL BATTERY CAPACITIES FOR RADIO TRANSMITTERS—Characteristic curves and data on discharge tests. BURGESS BATTERY COMPANY.
28. B BATTERY LIFE—Battery life curves with general curves on tube characteristics. BURGESS BATTERY COMPANY.
29. HOW TO MAKE YOUR SET WORK BETTER—A non-technical discussion of general radio subjects with hints on how reception may be bettered by using the right tubes. UNION RADIO AND ELECTRIC CORPORATION.
30. TUBE CHARACTERISTICS—A data sheet giving constants of tubes. C. E. MANUFACTURING COMPANY.
31. FUNCTIONS OF THE LOUD SPEAKER—A short, non-technical general article on loud speakers. AMPLION CORPORATION OF AMERICA.
32. METERS FOR RADIO—A catalogue of meters used in radio, with connecting diagrams. BURTON-ROGERS COMPANY.
33. SWITCHBOARD AND PORTABLE METERS—A booklet giving dimensions, specifications, and shunts used with various meters. BURTON-ROGERS COMPANY.
34. COST OF B BATTERIES—An interesting discussion of the relative merits of various sources of B supply. HARTFORD BATTERY MANUFACTURING COMPANY.
35. STORAGE BATTERY OPERATION—An illustrated booklet on the care and operation of the storage battery. GENERAL LEAD BATTERIES COMPANY.
36. CHARGING A AND B BATTERIES—Various ways of connecting up batteries for charging purposes. WESTINGHOUSE UNION BATTERY COMPANY.
37. CHOOSING THE RIGHT RADIO BATTERY—Advice on what dry cell battery to use; their application to radio, with wiring diagrams. NATIONAL CARBON COMPANY.
53. TUBE REACTIVATOR—Information on the care of vacuum tubes, with notes on how and when they should be reactivated. THE STERLING MANUFACTURING COMPANY.
54. ARRESTERS—Mechanical details and principles of the vacuum type of arrester. NATIONAL ELECTRIC SPECIALTY COMPANY.
55. CAPACITY CONNECTOR—Description of a new device for connecting up the various parts of a receiving set, and at the same time providing bypass condensers between the leads. KURZ-KASCH COMPANY.

Mayolian "B" SUPPLY

The "B" Without a Buzz

This Non-Motor boating, high-powered unit delivers 50 mils. at 200 volts.

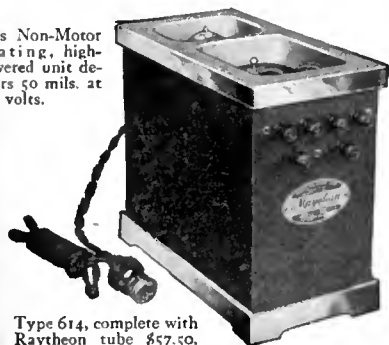

Type 614, complete with Raytheon tube \$57.50.

MAYOLIAN CORPORATION

1668 Webster Ave., New York City

Pioneers in Battery Elimination



The Power of Niagara—
The Quiet of an Arctic Night

play safe

CLAROSTAT is the perfect variable resistor for every radio purpose; for

Micrometric regeneration for short wave receivers—Variable grid leak for transmitting tubes—Line control for voltage compensation—Eliminator voltage control—Volume control—R. F. tube plate voltage control.

American Mechanical Labs., Inc.
285 N. 6th Street, Brooklyn, N. Y.

WARNING! Don't be misled by poor imitations. Look for the name CLAROSTAT.

CLAROSTAT

Send 25¢ for 32 page illustrated book

KARAS 23-Plate .0005 ORTHOMETRIC CONDENSERS

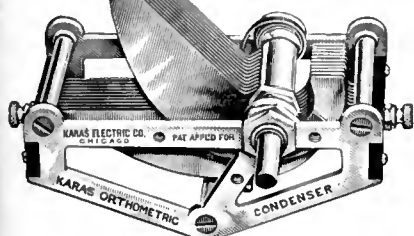

Will Vastly Improve Your Superheterodyne

To get the utmost in performance out of your super you must use Karas Straight Frequency Line "Orthometric" Variable Condensers. These superb condensers have the lowest losses known. They are precision-built by expert engineers. Use Karas 23 plate .0005 Orthometrics for superheterodyne work. If your dealer is out of stock you may order from us by using coupon, sending no money, but handing postman price of condensers, plus postage upon delivery.

KARAS ELECTRIC CO.
1065-B Association Building Chicago

KARAS ELECTRIC CO., 1065-B Association Bldg. Chicago
Send me Karas 23-plate Orthometric Condensers, price \$7 each, for which I will pay postman, plus postage, upon delivery.

Name.....
Address.....
City.....State.....
(If cash accompanies order, we will ship postpaid)

RAYTHEON MANUFACTURING COMPANY

MAKERS OF RELIABLE RECTIFIERS

KENALL SQUARE BUILDING

CAMBRIDGE, MASS.

March 31, 1927

Aerovox Wirelesa Corporation
70 Washington Straat
Brooklyn, New York

Gentlemen:

Attention of Mr. S. I. Cole

From time to time our laboratory has made careful and constructive tests on the condensers manufactured by your company for use with our type "B" rectifier in B-Power Supply Units, for use with the "BH" rectifier and in B-Power Supply Units and in "A-B-C" Units using both the "BH" and "BA" 350 milliampere rectifier.

The performance of these condensers has been entirely satisfactory when used in these circuits and the actual measured capacitance has not varied from the rated value more than three percent.

The non-inductiva type of construction used in your condensers is highly recommended for these circuits as our tests show filter circuits using this non-inductive type of capacitance to have greater efficiency for a given number of microfarads used.

Manufacturers of high quality B-Power Units have realized that an adequate safety factor in condenser construction is essential for continuous satisfactory service and your efforts to develop a high quality condenser will undoubtedly react to the mutual benefit of those now interested in the socket power field.

From the results of our tests we are glad to recommend your condensers, to manufacturers interested in the development of quality B-Power Units.

Sincerely yours,
RAYTHEON MANUFACTURING COMPANY

AEROVOX

By *D. E. Raplogle*

D. E. Raplogle
Sales Engineer

70 Washington Street Brooklyn, N. Y. CABLE ADDRESS: RAYTHMANCO

BOOKS

in a minute

by TELEGRAPH

DOUBLEDAY, PAGE BOOK SHOPS

New York Newark Toledo
Kansas City Cleveland St. Louis

ASTOUNDING!

"The only word that describes the reproduction of the 'ENSCO' 3 foot Cone or Roll type Speaker." The statement of one of the foremost Acoustic Engineers.

Kit GENUINE Kit
\$10 "ENSCO" \$10

Why has "ENSCO" been endorsed by all leading magazines and the foremost newspapers? Because it is the most highly developed big cone assembly now offered to the public, it reproduces all frequencies. The "ENSCO" unit is the only direct-drive unit for large cone speakers.

Manufactured under U. S. Patent No. 1630119; "ENSCO" Cushion Drive Patent No. 1163854; Cone Diaphragm Patent No. 1003655, and other patents pending.

Assemble the "ENSCO" speaker in less than an hour. It works on any set with any power. No filters or chokes necessary, 90 to 250 volts without protection or 500 volts with transformer.

Six different types to choose from. Cones beautifully decorated and marked for assembly. Wall, pedestal, or console; all fully described in illustrated instruction book.

Sold under absolute (money back) guarantee.

ENGINEERS SERVICE COMPANY

25 Church St. New York City
73 Cornhill Boston
28 E. Jackson Blvd. Chicago

Ask your dealer or mail order to nearest office. Send money order, check, or cash, or we will ship C.O.D. We pay shipping charges.



Ask us for a list of the latest models of rectifiers for which Hammarlund Products are officially specified

For Better Radio
Hammarlund
PRECISION
PRODUCTS

Write for illustrated literature describing the World-famous Hammarlund-Roberts "Hi-Q" Rectifier.

28 Leading Radio Engineers Specify
Hammarlund Products In Their Newest Receivers

HAMMARLUND MANUFACTURING COMPANY
424-438 W. 33rd Street, New York

PAR-VOLT

(Formerly Sangamo)

WOUND CONDENSERS

Stand the surges



Capacities and prices

Series A 400 Volt Duty	Mfds.	Series B 800 Volt Duty
\$.85	.1	\$1.25
.95	.25	1.50
1.00	.5	2.00
1.25	1.0	2.50
2.25	2.0	3.50
4.00	4.0	6.00

We recommend Sangamo Mica Condensers



6131-1

The Acme Wire Co., New Haven, Ct.

YAXLEY

APPROVED RADIO PRODUCTS



Automatic Power Control

Use the Automatic Power Control and Yaxley Radio Convenience Outlets and make this a perfect Radio Summer. The Power Control automatically takes care of the switching of your set. When you turn the set on the trickle charger is cut off and the B eliminator cut in. The reverse takes place when you turn off the set. With the Convenience Outlets you can place the set on front porch and keep your batteries in the basement or any convenient out-of-the-way place.

- No. 445—Automatic Power Control—Multiple Type, for any set ...\$6.00
 - No. 137—Convenience Outlet for Battery Connections.....2.50
 - No. 135—For Loud Speaker.....1.00
 - No. 136—For Aerial and Ground...1.00
- At your dealer's. If he cannot supply you, send his name with your order to

YAXLEY MFG. CO.

Dept. B 9 So. Clinton St. Chicago, Ill.

68. **CHEMICAL RECTIFIER**—Details of assembly, with wiring diagrams, showing how to use a chemical rectifier for charging batteries. CLEVELAND ENGINEERING LABORATORIES COMPANY.

69. **VACUUM TUBES**—A booklet giving the characteristics of the various tube types with a short description of where they may be used in the circuit. RADIO CORPORATION OF AMERICA.

77. **TUBES**—A booklet for the beginner who is interested in vacuum tubes. A non-technical consideration of the various elements in the tube as well as their position in the receiver. CLEARTRON VACUUM TUBE COMPANY.

87. **TUBE TESTER**—A complete description of how to build and how to operate a tube tester. BURTON-ROGERS COMPANY.

91. **VACUUM TUBES**—A booklet giving the characteristics and uses of various types of tubes. This booklet may be obtained in English, Spanish, or Portuguese. DEFORST RADIO COMPANY.

92. **RESISTORS FOR A. C. OPERATED RECEIVERS**—A booklet giving circuit suggestions for building a c. operated receivers, together with a diagram of the circuit used with the new 400-millampere rectifier tube. CARTER RADIO COMPANY.

97. **HIGH-RESISTANCE VOLTMETERS**—A folder giving information on how to use a high-resistance voltmeter, special consideration being given the voltage measurement of socket-power devices. WESTINGHOUSE ELECTRIC & MANUFACTURING COMPANY.

MISCELLANEOUS

38. **LOG SHEET**—A list of broadcasting stations with columns for marking down dial settings. U. S. L. RADIO, INCORPORATED.

41. **BBY RADIO TRANSMITTER OF 9XH-9EK**—Description and circuit diagrams of dry-cell operated transmitter. BURGESS BATTERY COMPANY.

42. **ARCTIC RADIO EQUIPMENT**—Description and circuit details of short-wave receiver and transmitter used in Arctic exploration. BURGESS BATTERY COMPANY.

43. **SHORT-WAVE RECEIVER OF 9XH-9EK**—Complete directions for assembly and operation of the receiver. BURGESS BATTERY COMPANY.

44. **ALUMINUM FOR RADIO**—A booklet containing much radio information with hook-ups of basic circuits, with inductance-capacity tables and other pertinent data. ALUMINUM COMPANY OF AMERICA.

45. **SHIELDING**—A discussion of the application of shielding in radio circuits with special data on aluminum shields. ALUMINUM COMPANY OF AMERICA.

58. **HOW TO SELECT A RECEIVER**—A commonsense booklet describing what a radio set is, and what you should expect from it, in language that any one can understand. DAY-FAN ELECTRIC COMPANY.

67. **WEATHER FOR RADIO**—A very interesting booklet on the relationship between weather and radio reception, with maps and data on forecasting the probable results. TAYLOR INSTRUMENT COMPANIES.

73. **RADIO SIMPLIFIED**—A non-technical booklet giving pertinent data on various radio subjects. Of especial interest to the beginner and set owner. CROSLY RADIO CORPORATION.

74. **THE EXPERIMENTER**—A monthly publication which gives technical facts, valuable tables, and pertinent information on various radio subjects. Interesting to the experimenter and to the technical radio man. GENERAL RADIO COMPANY.

75. **FOR THE LISTENER**—General suggestions for the selecting, and the care of radio receivers. VALLEY ELECTRIC COMPANY.

76. **RADIO INSTRUMENTS**—A description of various meters used in radio and electrical circuits together with a short discussion of their uses. JEWELL ELECTRICAL INSTRUMENT COMPANY.

78. **ELECTRICAL TROUBLES**—A pamphlet describing the use of electrical testing instruments in automotive work combined with a description of the cadmium test for storage batteries. Of interest to the owner of storage batteries. BURTON ROGERS COMPANY.

95. **RESISTANCE DATA**—Successive bulletins regarding the use of resistors in various parts of the radio circuit. INTERNATIONAL RESISTANCE COMPANY.

96. **VACUUM TUBE TESTING**—A booklet giving pertinent data on how to test vacuum tubes with special reference to a tube testing unit. JEWELL ELECTRICAL INSTRUMENT COMPANY.

98. **COPPER SHIELDING**—A booklet giving information on the use of shielding in radio receivers, with notes and diagrams showing how it may be applied practically. Of special interest to the home constructor. THE COPPER AND BRASS RESEARCH ASSOCIATION.

99. **RADIO CONVENIENCE OUTLETS**—A folder giving diagrams and specifications for installing loud speakers in various locations at some distance from the receiving set. YAXLEY MANUFACTURING COMPANY.

USE THIS COUPON

RADIO BROADCAST SERVICE DEPARTMENT
RADIO BROADCAST, Garden City, New York.
Please send me (at no expense) the following booklets indicated by numbers in the published list

.....

.....

.....

Name.....

Address.....

(Number) (Street)

(City) (State)

ORDER BY NUMBER ONLY
This coupon must accompany every request. RB 727

Use Power tubes for good quality at full volume

Simply adapt to your set with Connectoralds

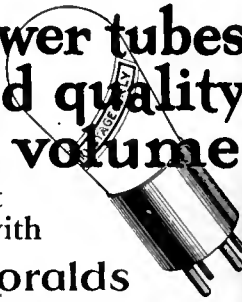

For UX 171 and UX 112 Tubes, Na-Aid 112 Connectoralds are recommended for maximum volume with storage battery sets. These tubes will deliver without distortion several times the volume of the regular 201A. Price \$1.50

For UX 120 Tubes in UV 201A sockets, the Na-Aid No. 120 Connectorald should be used. To convert a storage battery set to dry batteries with ample loud speaker volume, use a UX 120 tube in the last audio stage with the 120 Connectorald and UX 199 tubes with 419X Adapters in the other sockets. Price \$1.25.

For the UX 120 Tube in UV 199 sockets, ample loud speaker volume without distortion is obtainable from any set equipped for UV 199 tubes by means of the UX 120 or equivalent tube with the Na-Aid No. 920 Connectorald. The tube is raised slightly, but provides for its use in most sets with limited headroom. Price \$1.25.

For UX 120 tubes in the UV 199 sockets of the Radiola Superheterodyne Semi-Portable, and Radiola Super VIII. These excellent Superheterodynes will deliver ample volume for loud speaker operation when equipped with the UX 120 used with the Na-Aid No. 420 Connectorald. Price \$1.25.

ALDEN MANUFACTURING CO.
Dept. B-27 Springfield, Mass.

Independent Radio Corporation

Manufacturers of

Precision Radio Apparatus

1516 Summer Street

Philadelphia

The Best in Radio Programs

The first to review programs, RADIO BROADCAST, has maintained its interesting department of news and comment about broadcasters and their programs in "The Listeners' Point of View." A regular and lively department, conducted by John Wallace from his "listening-post" in Illinois.

CARTER

NEW COMPLETE LINE OF FIXED CONDENSERS



(Half Size)

A style for every circuit requirement.

The incessant demand for accurate condensers that are not only made accurately but are unaffected by climatic conditions and which stay accurate has been met by this new Carter line.

Carter reputation for quality parts is your strongest guarantee. You will find that these condensers will fully come up to what you expect.

Any dealer can supply

In Canada: Carter Radio Co., Ltd., Toronto

CARTER RADIO CO.



CHICAGO

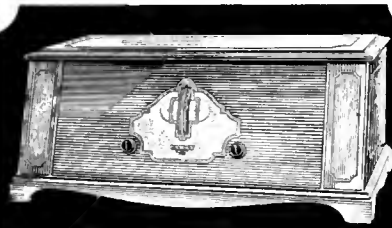

NOW READY



ELECTRIC SENIOR

(No Batteries)

ELKAY SENIOR

(Six Tubes)

ELKAY JUNIOR

(Six and Seven Tubes)

Write for literature

Jobbers, Dealers—write for territorial rights

The Langbein-Kaufman Radio Co.
Dept. R, 62 Franklin St., New Haven, Conn.

Use
Elkay Tube Equalizers

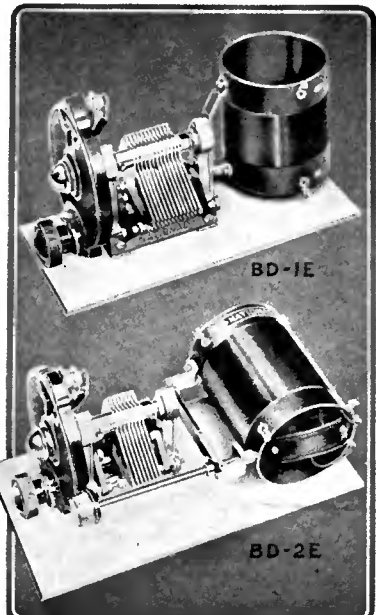

NATIONAL TUNING UNITS

Employing the official and genuine

BROWNING-DRAKE

R. F. Transformers and Coils

When you build your next set use these new units, comprising the new NATIONAL EQUI-TUNE Condensers, the NATIONAL ILLUMINATED VELVET-VERNIER DIALS and the OFFICIAL and GENUINE BROWNING-DRAKE R. F. Transformers and Coils. You will have the thrill of building with carefully engineered products of high standards, a thrill equalled only by your pleasure at its excellent and consistent performance.

Price BD-1E, with Genuine BD Antenna Coil and .0005 Condenser \$10.75 Price BD-2E, with Genuine B-D Transformer and .00025 Condenser \$14.25

Deduct 50c each for dials without illumination

See us at the R. M. A. Show, Chicago

NATIONAL Tuning Units are standard for good Radio sets. So are NATIONAL Impedance Transformers for quality audio, NATIONAL Tone-Filters, for power tube output connection.



NATIONAL CO. makes heavy-duty B-Supply Units and 3-stage Power Amplifiers. National Company, Inc., Malden, Mass. Send for Bulletin 116-B.

RADIO FANS, a one-year's subscription to Radio Broadcast will cost you four dollars, two years six dollars. Consider this expenditure as being a necessary investment on your part for the future development of your own knowledge of Radio.

Make any Good Receiver

BETTER

C. E. MFG. CO.
Inc.
Providence
R.I.

CC TUBES



LYNCH

RESISTORS

ARTHUR H. LYNCH, Inc.
1775 Broadway General Motors Building New York City

Hoyt

**B
ELIMINATOR
VOLTMETER**

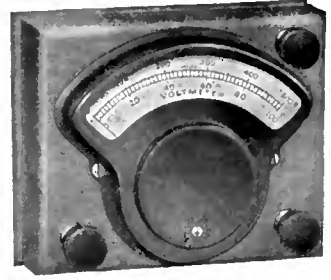

A new sensitive voltmeter, for regular Dealers' service work as well as for laboratory and precision measurements. Resistance 1,000 ohms per volt. Provided with two scales,—0-100 volts and 0-500 volts, covering the entire range of ordinary B-Eliminator and Power-Amplifier work.

Prices, HOYT Standard B-Eliminator Voltmeter, 0-100 and 0-500 volts—\$28.00.
Supplied on special order with additional scale, either:—0-10 volts or 0-100 ma. at \$32.50.
Send for Price List B-6

BURTON-ROGERS CO.
857 BOYLSTON ST., BOSTON, MASS.
Sales Dept. for HOYT Electrical Instrument Works

Learn the Code at Home With the Omnigraph

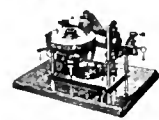

Morse and Wireless—taught at home in half usual time and at trifling cost. Omnigraph Automatic Transmitter will send, on Sounder or Buzzer, unlimited messages, any speed, just as expert operator would. Adopted by U. S. Govt. and used by leading Universities, Colleges, Technical and Telegraph Schools throughout U. S. Send 6c for Catalog.

OMNIGRAPH MFG. CO., 13K, Hudson St., New York

RADIO PANELS

OF GENUINE BAKELITE

Cut, drilled and engraved to order. Send rough sketch for estimate. Our complete Catalog on Panels, Tubes and Rods—all of genuine Bakelite—mailed on request.

STARRETT MFG. CO.

521 S. Green Street Chicago, Ill.

This is a good time to subscribe for RADIO BROADCAST Through your dealer or direct, by the year only \$4.00
DOUBLEDAY, PAGE & CO. GARDEN CITY, NEW YORK



HEAVY DUTY WIRE WOUND RHEOSTATS—POTENTIOMETERS

Designed especially for heavy current control. Impossible to break down under high temperatures. Limiting factor is the fusion point of the Nichrome or Advance Wire used. These units dissipate over 50 watts at 482° Fahrenheit. Diameter—2 inches, single hole mounting.
500 ohm Centralab Power Rheostat \$1.75
150 ohm Centralab Power Potentiometer 1.75
At your dealer's, or mailed direct

Central Radio Laboratories
22 Keefe Ave. Milwaukee, Wis.



Electrostatic condensers for all purposes



WIRELESS SPECIALTY APPARATUS COMPANY
Jamaica Plain
Boston, Mass.

Why not subscribe to *Radio Broadcast*? By the year only \$4.00; or two years, \$6.00, saving \$2.40. Send direct to Doubleday, Page & Company, Garden City, New York.

\$75 A WEEK BUILDING RADIO SETS

In Your Spare Time

Join the Radio Association of America. Learn how to build and repair sets. The Association will train you—start you out in business, if you wish. Be the radio "doctor" of your community. \$3 an hour upwards easily made.

Earns \$500 in Spare Time

"I have at last found myself", writes Lyle Follicke, Lansing, Mich. "I have already made over \$500." Werner Eichler, Rochester, N.Y., "... have made over \$50 a week in my spare time." Our members are starting radio stores, increasing their salaries, securing better positions, passing radio operator examinations, earning big money in spare time.

Join Association Now

Are you interested in Radio for pleasure or profit? Join now because we have a Special Plan whereby your membership need not cost you a cent. Only limited number of these memberships acceptable. Write now for details—before it is too late.

Mail this Coupon—

Radio Association of America,
Dept. R, 4513 Ravenwood Ave., Chicago

Send me details of your special Radio Association Membership Plan.

Name.....

Address.....

City..... State.....



EL Menco
HY-WATT
TRADE MARK
HEAVY DUTY RESISTORS

For best results with Raytheon and other power circuits you must have permanently accurate resistors capable of carrying heavy loads without change or deterioration. "HY-WATT" Heavy Duty Resistors dissipate up to 12 watts.

100-500-1000-2000-5000 ohms \$1.25
10,000-25,000-50,000 ohms \$1.50
100,000 ohms \$2.00

Write for full details and literature on El Menco Gridleaks and Resistors
Electro-Motive Engineering Corp.
227 West 17th St. New York, N. Y.



Now
You can build the
kind of a radio you
have always wanted

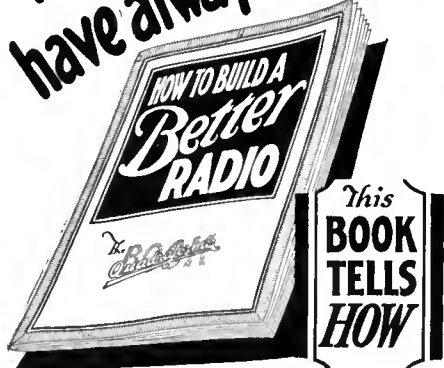

No matter whether you want to improve a set you now have or build a new one - get this book first. Tells how to build the latest one, two and three dial receivers - 5 to 7 tubes.

10¢ PREPAID
GEARHART-SCHLUETER, Fresno, Cal.

What Kit Shall I Buy?

THE list of kits herewith is printed as an extension of the scope of the Service Department of RADIO BROADCAST. It is our purpose to list here the technical data about kits on which information is available. In some cases, the kit can be purchased from your dealer complete; in others, the descriptive booklet is supplied for a small charge and the parts can be purchased as the buyer likes. The Service Department will not undertake to handle cash remittances for parts, but when the coupon on page 191 is filled out, all the information requested will be forwarded.

- 201. SC. FOUR-TUBE RECEIVER—Single control. One stage of tuned radio frequency, regenerative detector, and two stages of transformer-coupled audio amplification. Regeneration control is accomplished by means of a variable resistor across the tickler coil. Standard parts; cost approximately \$58.85.
- 202. SC-II FIVE-TUBE RECEIVER—Two stages of tuned radio frequency, detector, and two stages of transformer-coupled audio. Two tuning controls. Volume control consists of potentiometer grid bias on r.f. tubes. Standard parts cost approximately \$60.35.
- 203. "HI-Q" KIT—A five-tube tuned radio-frequency set having two radio stages, a detector, and two transformer-coupled audio stages. A special method of coupling in the r.f. stages tends to make the amplification more nearly equal over the entire band. Price \$63.05 without cabinet.
- 204. R. G. S. KIT—A four-tube inverse reflex circuit, having the equivalent of two tuned radio-frequency stages, detector, and three audio stages. Two controls. Price \$69.70 without cabinet.
- 205. PIERCE AIRO KIT—A six-tube single-dial receiver; two stages of radio-frequency amplification, detector, and three stages of resistance-coupled audio. Volume control accomplished by variation of filament brilliancy of r.f. tubes or by adjusting compensating condensers. Complete chassis assembled but not wired costs \$42.50.
- 206. H & H-T. R. F. ASSEMBLY—A five-tube set; three tuning dials, two steps of radio frequency, detector, and 2 transformer-coupled audio stages. Complete except for base-board, panel, screws, wires, and accessories. Price \$35.00.
- 207. PREMIER FIVE-TUBE ENSEMBLE—Two stages of tuned radio frequency, detector, and two steps of transformer-coupled audio. Three dials. Parts assembled but not wired. Price complete, except for cabinet, \$35.00.
- 208. "QUADRAFORMER VI"—A six-tube set with two tuning controls. Two stages of tuned radio frequency using specially designed shielded coils, a detector, one stage of transformer-coupled audio, and two stages of resistance-coupled audio. Gain control by means of tapped primaries on the r.f. transformers. Essential kit consists of three shielded double-range "Quadraformer" coils, a selectivity control, and an "Ampitrol," price \$17.50. Complete parts \$70.15.
- 209. GEN-RAI FIVE-TUBE SET—Two stages of tuned radio frequency, detector, and two transformer-coupled audio stages. Volume is controlled by a resistor in the plate circuit of the r.f. tubes. Uses a special r.f. coil ("Duo-Former") with figure eight winding. Parts mounted but not wired, price \$37.50.
- 210. BREMER-TULLY POWER-SIX—A six-tube, dual-control set; three stages of neutralized tuned radio frequency, detector, and two transformer-coupled audio stages. Resistances in the grid circuit together with a phase shifting arrangement are used to prevent oscillation. Volume control accomplished by variation of B potential on r.f. tube. Essential kit consists of four r.f. transformers, two dual condensers, three small condensers, three choke coils, one 500,000-ohm resistor, three 1500-ohm resistors, and a set of color charts and diagrams. Price \$41.50.
- 211. BRUNO DRUM CONTROL RECEIVERS—How to apply a drum tuning unit to such circuits as the three-tube regenerative receiver, four-tube Browning-Drake, five-tube Diamond-of-the-Air, and the "Grand" 6.
- 212. INFRADYNE AMPLIFIER—A three-tube intermediate-frequency amplifier for the super-heterodyne and other special receivers, tuned to 3490 kc. (86 meters). Price \$25.00.
- 213. RADIO BROADCAST "LAB" RECEIVER—A four-tube dual-control receiver with one stage of Rice neutralized tuned-radio frequency, regenerative detector (capacity controlled), and two stages of transformer-coupled audio. Approximate price, \$78.15.
- 214. LC-27—A five-tube set with two stages of tuned-radio frequency, a detector, and two stages of transformer-coupled audio. Special coils and special means of neutralizing are employed. Output device. Price \$85.20 without cabinet.
- 215. LOFTIN-WHITE—A five-tube set with two stages of radio frequency, especially designed to give equal amplification at all frequencies, a detector, and two stages of transformer-coupled audio. Two controls. Output device. Price \$85.10.
- 216. K.H.-27—A six-tube receiver with two stages of neutralized tuned radio frequency, a detector, three stages of choke-coupled audio, and an output device. Two controls. Price \$86.00 without cabinet.
- 217. AERO SHORT-WAVE KIT—Three plug-in coils designed to operate with a regenerative detector circuit and having a frequency range of from 19,990 to 2306 kc. (15 to 130 meters). Coils and plug only, price \$12.50.
- 218. DIAMOND-OF-THE-AIR—A five-tube set having one stage of tuned-radio frequency, a regenerative detector, one stage of transformer-coupled audio, and two stages of resistance-coupled audio. Volume control through regeneration. Two tuning dials.
- 219. NORDEN-HAUCK SUPER 10—Ten tubes; five stages of tuned radio frequency, detector, and four stages of choke- and transformer-coupled audio frequency. Two controls. Price \$201.40.
- 220. BROWNING-DRAKE—Five tubes; one stage tuned radio frequency (Rice neutralization), regenerative detector (tickler control), three stages of audio (special combination of resistance- and impedance-coupled audio). Two controls.

\$12.50 complete

Electric Reproduction from your old Phonograph!

A Patent Phonovox, together with your radio set, converts your old style phonograph into electric reproduction in tone quality and range. Easily and quickly attached without tools—no changes in the wiring or additions of other accessories necessary.

Your dealer carries the Phonovox or will gladly get one for you.

PHONOVOX
Patent Radio Corp.
156 West 16th St.
New York

If you like this magazine with its coated paper and enlarged size—then why not subscribe and get it regularly — by the year, \$4.00, Six months, \$2.00.

Doubleday, Page & Co.
Garden City New York

\$25

The SONOCHORDE CONE

HEAR this beautiful cone on both music and voice and you'll never be satisfied with any other. Equipped with super-powered unit with four heavy magnets, balanced and angularly spaced. Rich wine-colored silk front, unbreakable mahogany finish frame, protected back.

See Your Dealer or Write Us for Sonochorde Facts.

BOUDETTE MFG. CO.
Chelsea, Mass.

AMSCO ORTHOPHONE



Connects instantly between radio set and loudspeaker. Permits volume without distortion. Protects the loudspeaker. Essential where power tubes are used.

AMSCO PRODUCTS, INC.
Broome and Lafayette Streets
New York City

WHAT KIT SHALL I BUY (Continued)

221. LR4 ULTRADYNE—Nine-tube super-heterodyne; one stage of tuned radio frequency, one modulator, one oscillator, three intermediate-frequency stages, detector, and two transformer-coupled audio stages.
222. GREIFF MULTIPLEX—Four tubes (equivalent to six tubes); one stage of tuned radio frequency, one stage of transformer-coupled radio frequency, crystal detector, two stages of transformer-coupled audio, and one stage of impedance-coupled audio. Two controls. Price complete parts, \$50.00.
223. PHONOGRAPH AMPLIFIER—A five-tube amplifier device having an oscillator, a detector, one stage of transformer-coupled radio frequency, and two stages of impedance-coupled audio. The phonograph signal is made to modulate the oscillator in much the same manner as an incoming signal from an antenna.

USE THIS COUPON

RADIO BROADCAST SERVICE DEPARTMENT
Garden City, New York.

Please send me information about the following kits indicated by number:

.....
.....
.....
.....

Name

Address
(Number) (Street)

(City) (State)

ORDER BY NUMBER ONLY. This coupon must accompany each order.

RB727

SET YOUR CLOCKS

THE correct time is now available nightly from WEAF, WEEI, WJAR, WGY, WTAM, WWJ, WGN, WCCO, WTIC, WFI, WSAI, WCAE, WOC, and KSD. Through an arrangement with the Howard Watch Company the time will be broadcast simultaneously through these stations each weekday night at 9:00 o'clock and on Sunday evenings at 9:15 Eastern Time. Station WJZ and network is likewise broadcasting the time, at 7:00 and 10:00 o'clock in the evening—or as close to these hours as its program permits. It seems absurd to confine these valuable announcements merely to one or two times in an evening.

KHJ COMPLETES 10,000 HOURS ON AIR

WITH the signing off of KHJ at Los Angeles on the completion of its fifth anniversary program on April 13, the pioneer station of the west coast completed 10,000 hours on the air during its first five years of broadcasting. The present daily schedule omits the afternoon hours but the station is on the air Tuesdays to Saturdays inclusive from 6 to 10 P. M.; Sundays from 10:30 to noon and from 7 to 10 P. M.; Monday is silent day.

TECHNICAL INFORMATION INQUIRY BLANK

Technical Service,
RADIO BROADCAST LABORATORY,
Garden City, New York.

GENTLEMEN:

Please give me fullest information on the attached questions. I enclose a stamped addressed envelope.

I am a subscriber to RADIO BROADCAST, and therefore will receive this information free of charge.

I am not a subscriber and enclose \$1 to cover cost of the answer.

NAME

ADDRESS R. B. Jy.

Announcement

Sterling

"A" LIGHT-SOCKET POWER UNITS



They're here—two perfected light-socket power supply units—eliminators of all "A" batteries and chargers.

Two models—R-96-Raytheon for 6 volt and R-94-G. E. bulb for 4 volt, Radiolas especially.

Sterling model R-96 is universal for all sets using 3 to 10 large tubes. Employs Raytheon's new 2 1/2 ampere rectifier. No heat—no bulb—no breakage—long lived.

Sterling indicator makes this unit adjustable to point of highest operating efficiency and lowest power cost.

These units have two stages of filter, large capacity, smoothing out the last trace of hum.

Automatic switch gives instant control of all power when used with "B" eliminator or "B" batteries.

One installation, one adjustment—and your "A" troubles are ended. Ask your dealer to show you this remarkable Sterling "A" Power unit.

Sterling

"A" POWER UNITS

The Sterling Mfg. Company
2831-53 Prospect Ave., Cleveland, Ohio

Dealers—Don't miss the complete Sterling display at the Chicago R. M. A. Show, Booth 68.



Helpful Technical Information

A regular feature of RADIO BROADCAST is the series of Laboratory Information Sheets, which cover a wide range of information of immediate value to every radio worker, presented in a form making it easy to preserve them. To insure your having every issue, send your check for \$4.00 to

Subscription Department, Doubleday, Page & Co.,
Garden City, N. Y.

RADIO PRODUCTS



manufactured under the BRUNO trade mark have been produced by the same management for over five years.

The story of BRUNO quality is best told in the results obtained from BRUNO Parts.

BRUNO Coils, Brackets, Kits, Unit-tunes, Condensers & Light Switches can be had at your Dealer or direct from us.

Our NEW 36 page booklet thoroughly explains our line.

Send 25 cents for your copy

BRUNO RADIO CORPORATION
Long Island City New York



R U ONE?

Co-operative membership in E I A RADIO is establishing an honest, industrious man in each locality in a successful radio industry of his own. Young married men preferred. Apply by letter, giving the name of your county, to

EQUITABLE INDUSTRIES ASS'N, RADIO DIV.
350-B Broadway, New York

*Drum notes not only heard —
but identified*

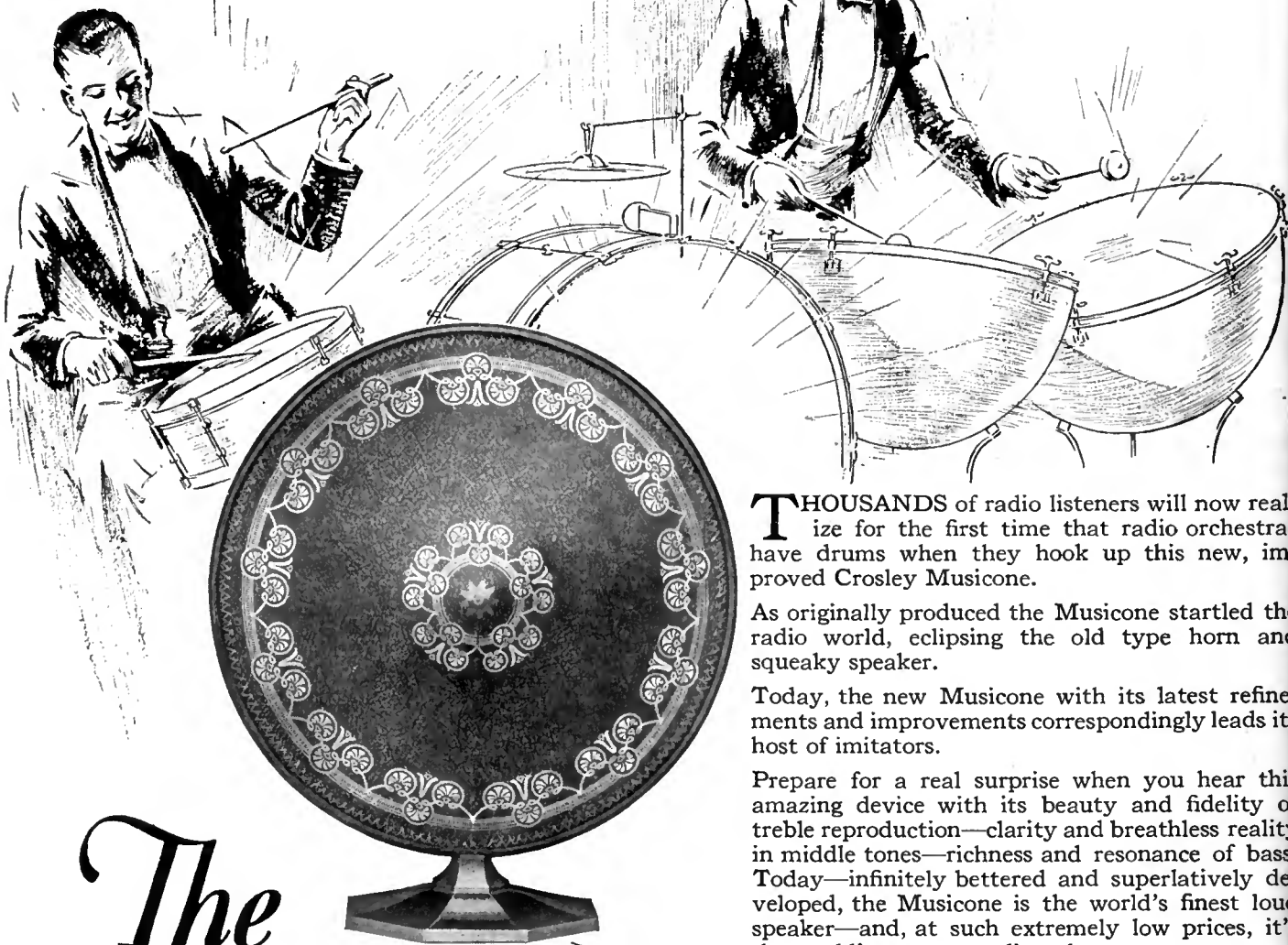

THOUSANDS of radio listeners will now realize for the first time that radio orchestras have drums when they hook up this new, improved Crosley Musicone.

As originally produced the Musicone startled the radio world, eclipsing the old type horn and squeaky speaker.

Today, the new Musicone with its latest refinements and improvements correspondingly leads its host of imitators.

Prepare for a real surprise when you hear this amazing device with its beauty and fidelity of treble reproduction—clarity and breathless reality in middle tones—richness and resonance of bass. Today—ininitely bettered and superlatively developed, the Musicone is the world's finest loud speaker—and, at such extremely low prices, it's the world's greatest radio value.

The Crosley patented actuating unit (and *not* the cone) is the secret. There's nothing else like it.

Write Dept. 20 for descriptive literature.

*The
improved*
**CROSLEY
MUSICONE**

SUPER-MUSICONE

16 inch Cone

\$14.75

THE CROSLEY RADIO CORPORATION

POWEL CROSLEY, JR.
Pres.



CINCINNATI,
OHIO

Prices slightly higher west of the Rocky Mountains

ULTRA-MUSICONE

12 inch Cone

\$9.75

the CROSLLEY "Bandbox"

and other new radio reception equipment for the complete enjoyment of the 1927-28 radio season



Ever since Crosley entered the radio field their methods and developments have created a leading place for Crosley radio receivers.

Recent court decisions now greatly clarify radio patent situation

And now—completely available to Crosley—and amplifying Crosley supremacy in fullest measure, are the enormous resources, discoveries and ideas, embodied in patents of the Radio Corporation of America, The Westinghouse Co., The General Electric Co., and The American Telephone and Telegraph Co.—under which Crosley is now licensed to manufacture.

No wonder the new Crosley receivers are in the forefront, their amazing efficiency acknowledged and demanded by that section of the radio trade which insists on the latest and best at all times.

THE "BANDBOX"

It is a new 6-tube set of astonishing sensitiveness.

Many exceptional features commend the "Bandbox."

The metal outside case, 'tho keeping out strong local signals effectually enough, did not fully satisfy Crosley ideals of fine radio reception. Signals must be kept in order *inside the set*.



Coils and condensers are like families living in a row of houses with no fences between. The children run around the yards; they meet, mix it up, quarrel and squabble. No harmony.

Magnetic and electric fields are the offspring of coils and condensers. With no fence between, they, too, run around the house, mix it up, quarrel and squabble. Howls and squeals result.



So, to keep each "family" or field of individual coils and condensers separated, metal fences are erected (copper fences for the coils) and the individual parts of the Bandbox are shielded as only found in the highest priced sets.



For fans who love to go cruising for faint, far-away signals the "Acuminators" intensify weak signals like powerful lens revealing distant scenes.

The "Bandbox" employs completely balanced or neutralized radio frequency stages, instead of the common or lossier method of preventing oscillation. In presenting this important feature Crosley is exclusive in the field of moderate price radio.



Volume control is another big "Bandbox" feature. Signals from powerful local stations can

be cut from room filling volume to a whisper. Each "Bandbox" is fitted with a brown cable containing colored rubber covered leads for power and other connections.

The frosted brown crystalline finish harmonizes with the finest furniture and matches the frames of Musicones and the casing of the power unit. The bronze escutcheon creates an artistic control panel.

Withal, in the beautiful appearance and modest size of the "Bandbox" is the utmost in adaptability to requirements of interior arrangement or decoration. The outside case is easily and quickly removed for installation in console cabinets.

AC AND BATTERY OPERATION

The "Bandbox" is built both for battery and AC operation. The new R.C.A.—AC tubes make the operation of the set directly from house current both practical and efficient.

In the AC set the radio stages and the first audio stage use the new R.C.A.—AC—UX-226 tubes. Filaments in these tubes are heated with raw AC current at proper voltage.

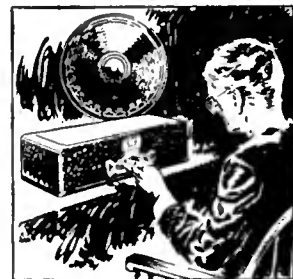
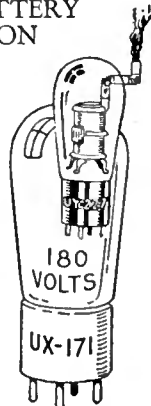

A Master Station Selector, with illuminated dial for shadowy corners, enables tuning for ordinary reception with a single tuning knob.

The UY-227, with indirectly heated emitter, is used with the detector. Power tube UX-171 at 180 volts plate.



There is no AC hum. The new R.C.A. Radiotrons do the work.

The power supply unit is a marvel of radio engineering ingenuity. Half the size of an ordinary "A" storage battery, it supplies A, B and C current direct from lamp socket to tubes.

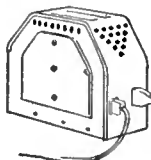

Models for 25 and 60 cycles. Snap switch shuts down set and power unit completely.

Write Dept. 20 for Descriptive Literature.

CROSLLEY RADIO

Crosley Radio is licensed only for Radio Amateur, Experimental and Broadcast Reception.

RCA Radiotrons are supplied at standard prices with each Crosley Receiver. Prices slightly higher west of Rocky Mountains.

THE CROSLLEY RADIO CORPORATION

Cincinnati, Ohio



Powell Crosley, Jr., Pres.



TILT-TABLE MUSICONE
\$27.50

Although Musicones improve the reception of almost any radio set they are perfect affinities in finish, beauty and reproductive effectiveness for Crosley Radios. A new model built in the form of a Colonial Tilt-table and finished in brown mahogany stands 3 feet high.

12-inch Ultra Musicone \$9.75	16-inch Super Musicone \$12.75
----------------------------------	-----------------------------------